

Proposal Basic Information	
Proposal File No.	JNP/EP/0074/W08/2019
Owner Name	SMT. RITA DEVI
Khata No	21
Plot No	169
Village Name	Moriyawa
Use	Residential
SubUse	Bungalow/ Dwelling / Non Apartment

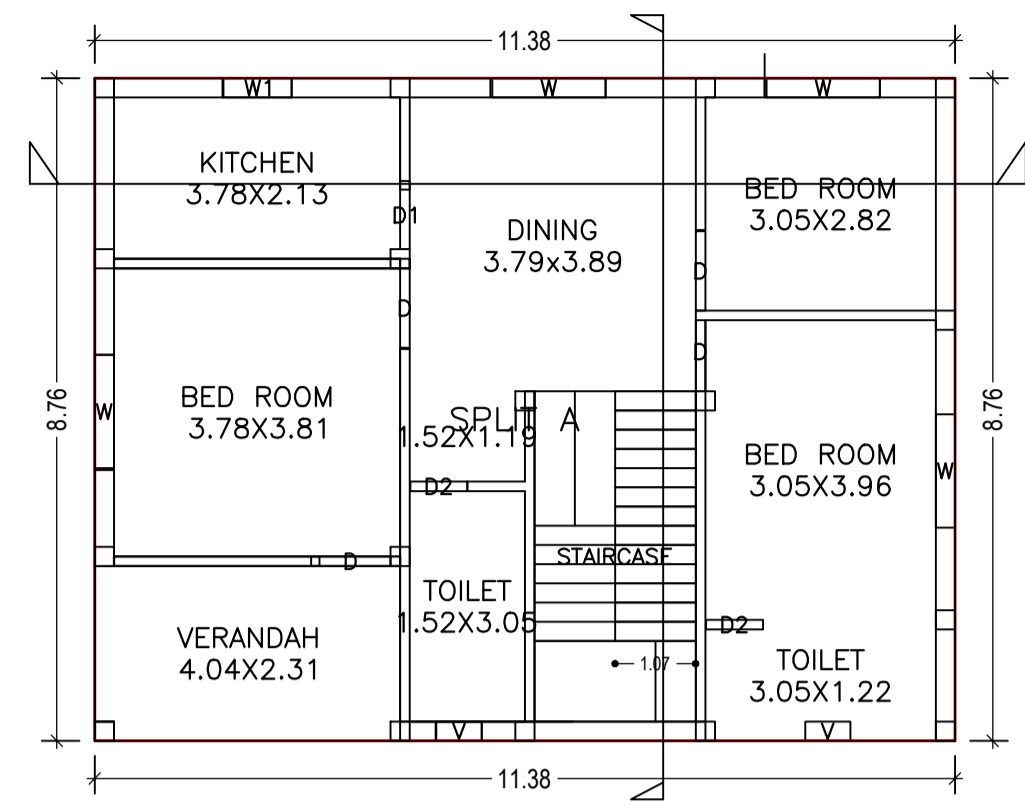

GROUND FLOOR PLAN
(Proposed)
(SCALE 1:100)

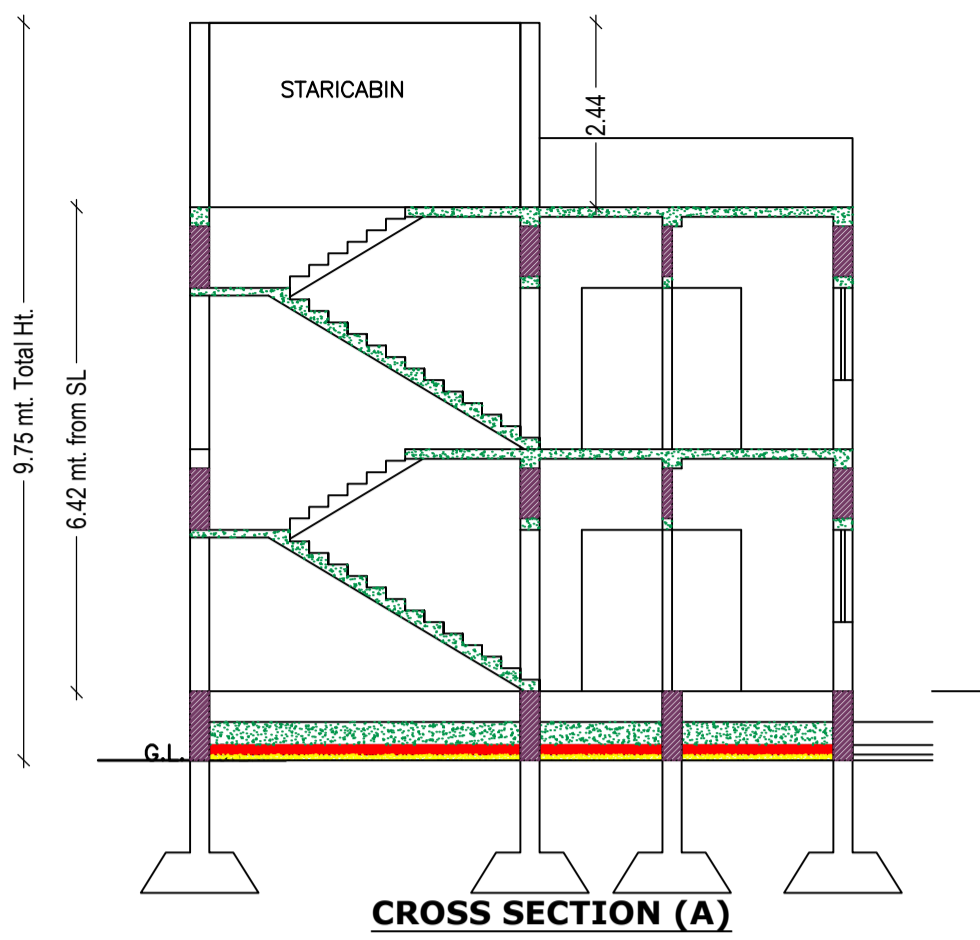

CROSS SECTION (A)

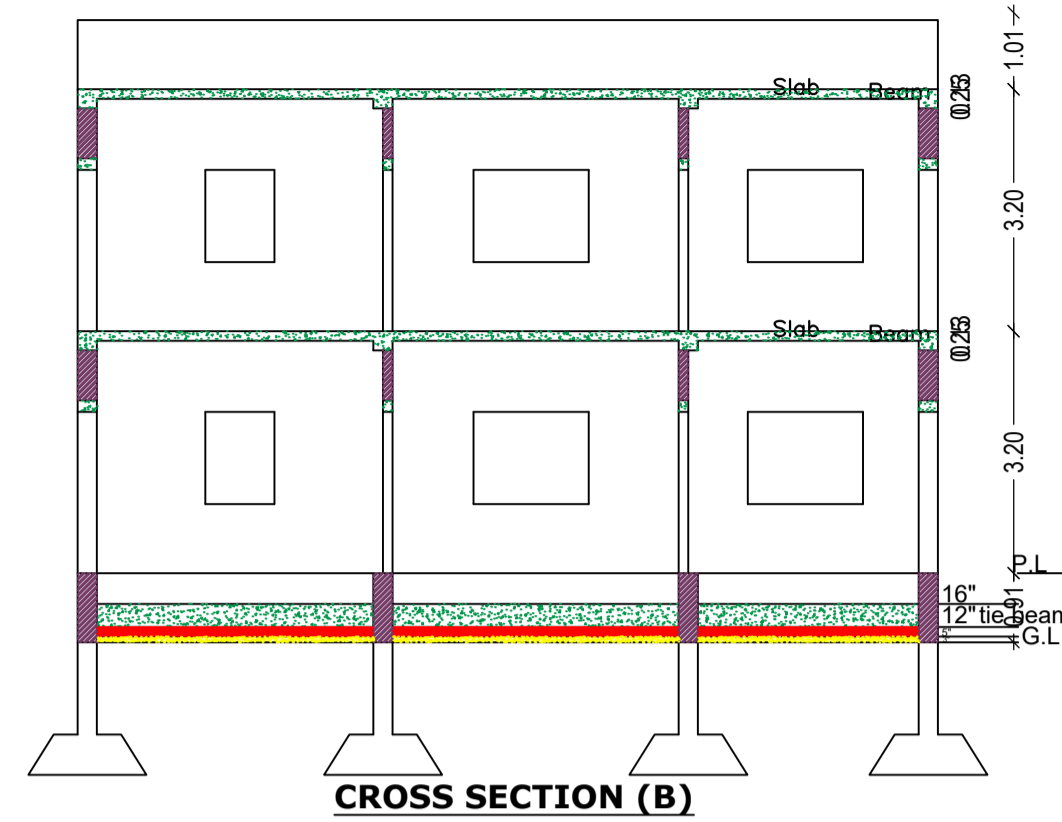

CROSS SECTION (B)

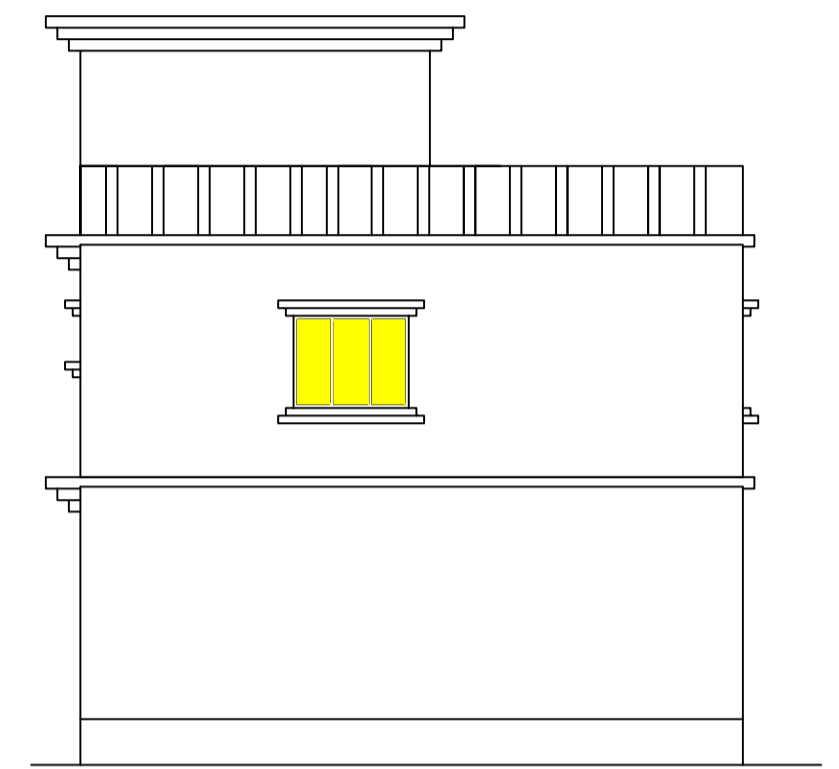

CROSS ELEVATION

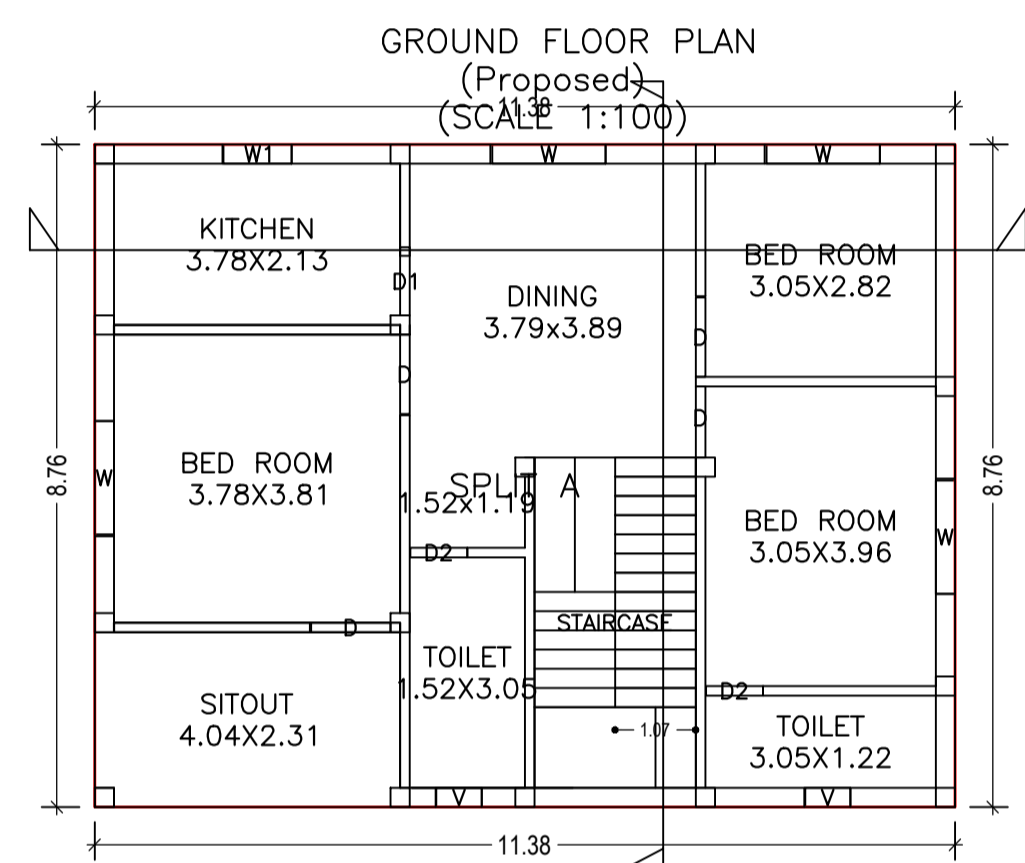

FIRST FLOOR PLAN
(Proposed)
(SCALE 1:100)

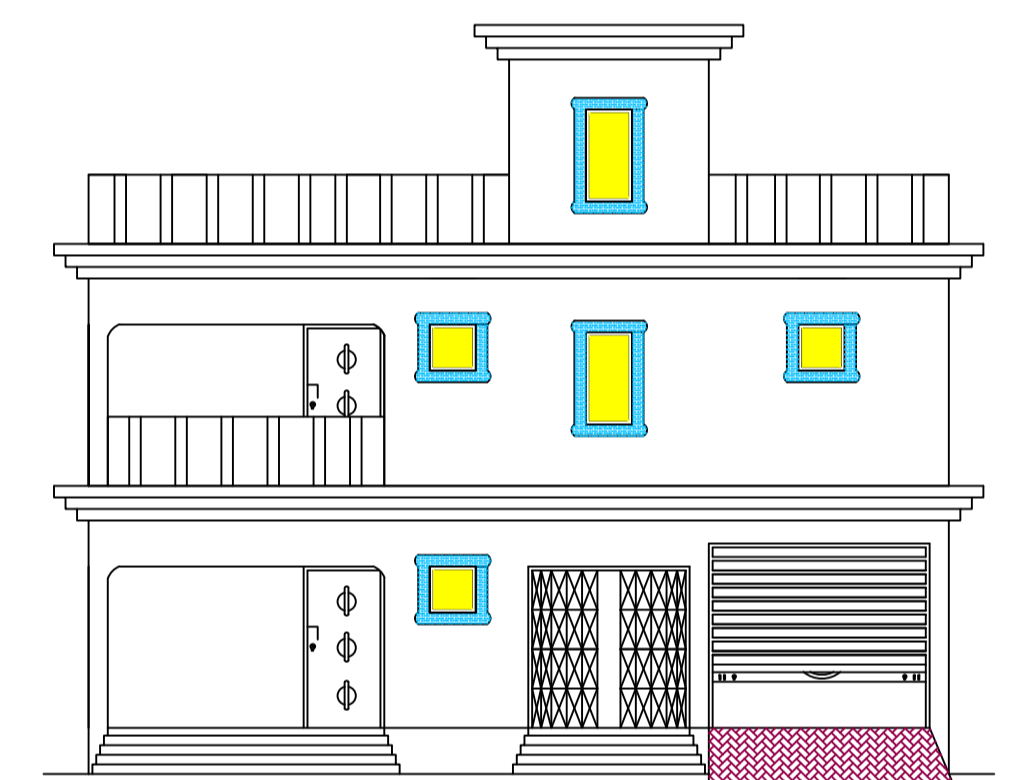

FRONT ELEVATION

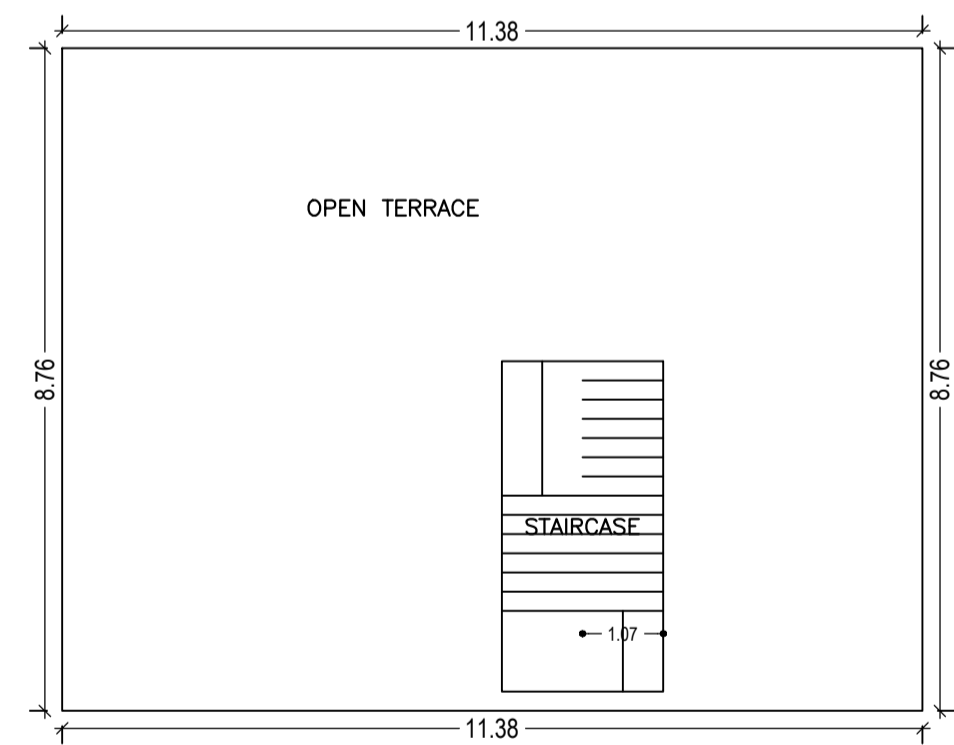

TERRACE FLOOR PLAN
(SCALE 1:100)

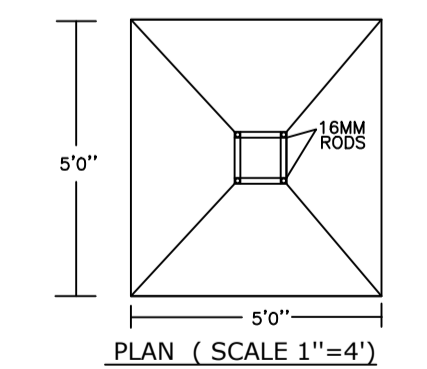
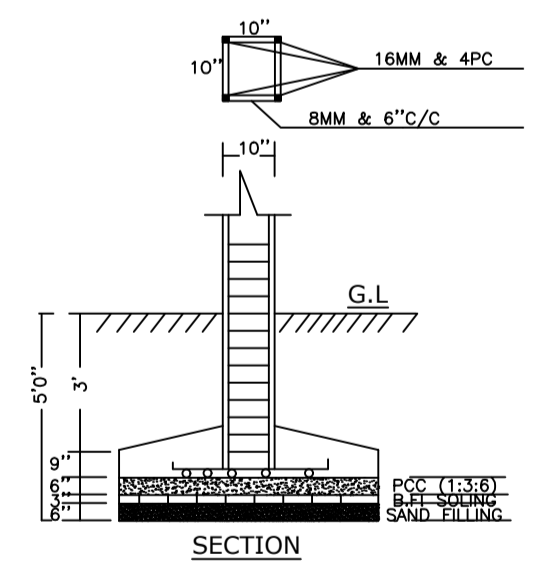
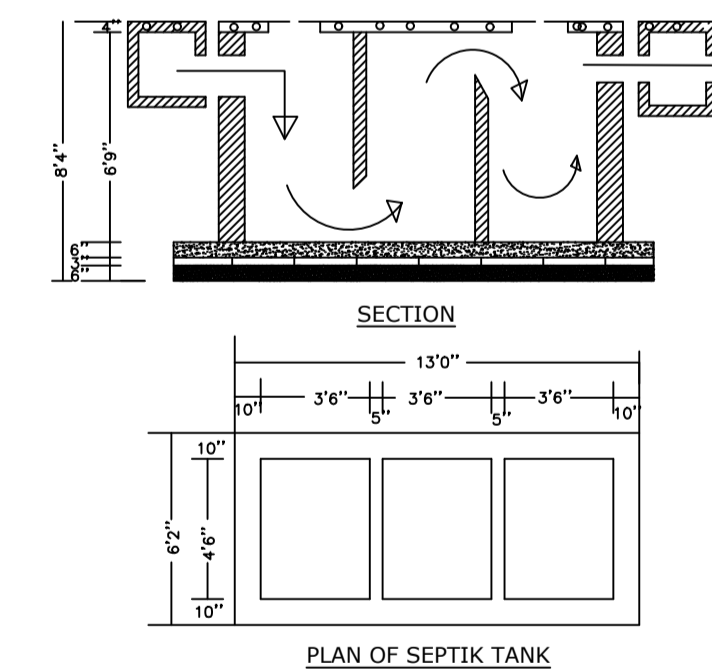
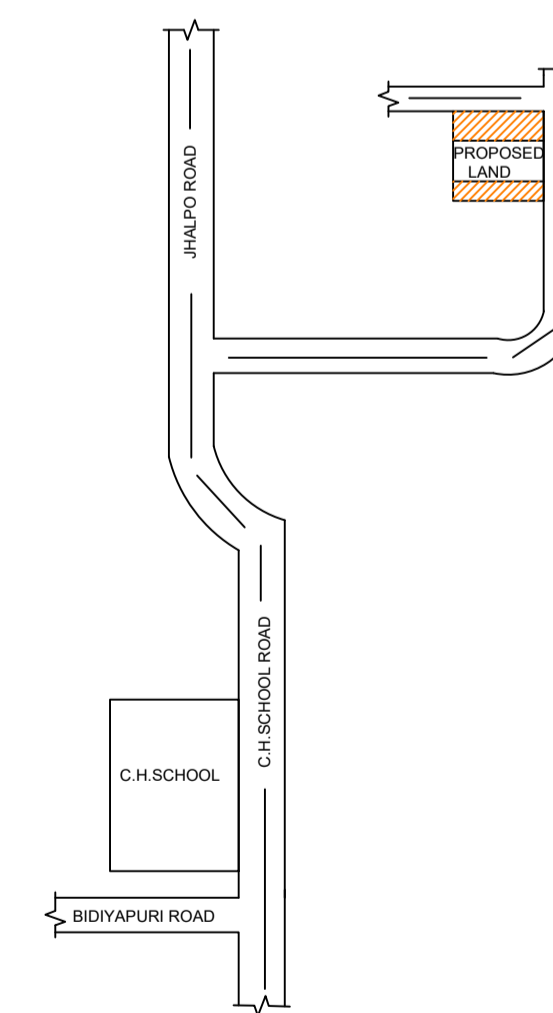

Building :A (RESIDENTIAL)

Floor Name	Total Built Up Area (Sq.mt.)	Proposed FAR Area (Sq.mt.)	Total FAR Area (Sq.mt.)	Total Consumed Additional FAR Area (Sq.mt.)	Tnmt (No.)
Ground Floor	99.72	99.72	99.72	99.72	01
First Floor	99.72	99.72	99.72	99.72	00
Terrace Floor	0.00	0.00	0.00	0.00	00
Total :	199.44	199.44	199.44	199.44	01
Total Number of Same Buildings	1				
Total :	199.44	199.44	199.44	199.44	01

SCHEDULE OF DOOR:

BUILDING NAME	NAME	LENGTH	HEIGHT	NOS
A (RESIDENTIAL)	D2	0.75	2.10	04
A (RESIDENTIAL)	D1	0.90	2.10	02
A (RESIDENTIAL)	D	0.94	2.10	02
A (RESIDENTIAL)	D	1.05	2.10	06

SCHEDULE OF WINDOW/VENTILATION:

BUILDING NAME	NAME	LENGTH	HEIGHT	NOS
A (RESIDENTIAL)	V	0.60	0.90	04
A (RESIDENTIAL)	W1	0.90	1.20	02
A (RESIDENTIAL)	W	1.50	1.20	08

UnitBUA Table for Building :A (RESIDENTIAL)

FLOOR	Name	UnitBUA Type	UnitBUA Area	Carpet Area	No. of Rooms	No. of Tenement
FIRST FLOOR PLAN	SPLIT A	FLAT	0.00	0.00	8	0
GROUND FLOOR PLAN	SPLIT A	FLAT	161.72	159.80	8	1
Total:	-	-	161.72	159.80	16	1

LTP NAME AND SIGNATURE	STRUCTURAL ENG'S NAME AND SIGNATURE	BUILDER NAME AND SIGNATURE	DIGITAL SIGNATURE
KIRAN KUMARI JNP/ENG/0001/2019			