

GROUND FLOOR PLAN (Proposed) (SCALE 1:100)

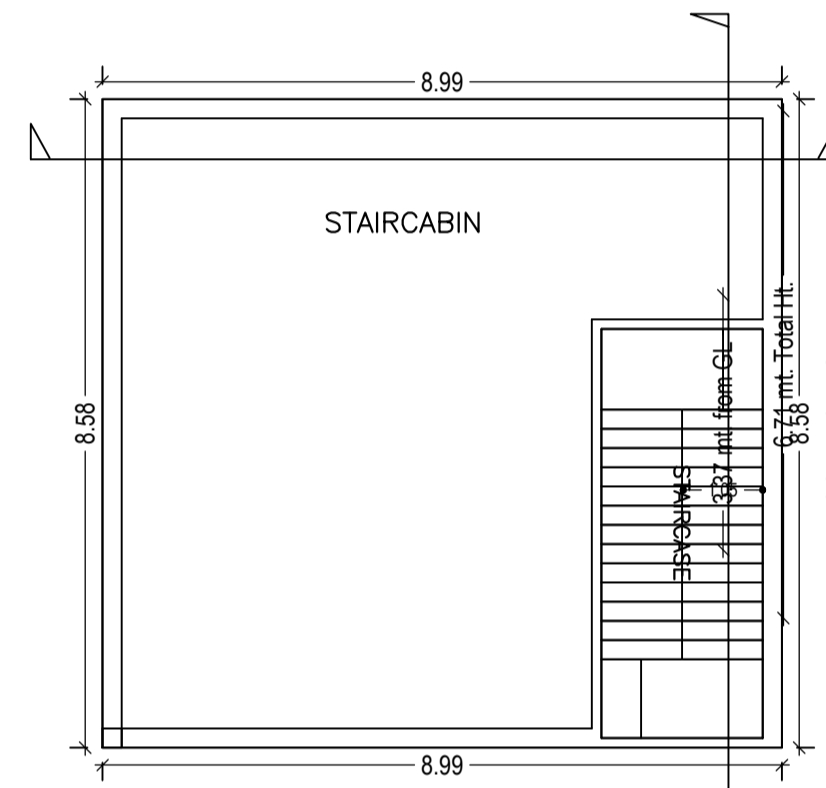

TERRACE FLOOR PLAN (SCALE 1:100)

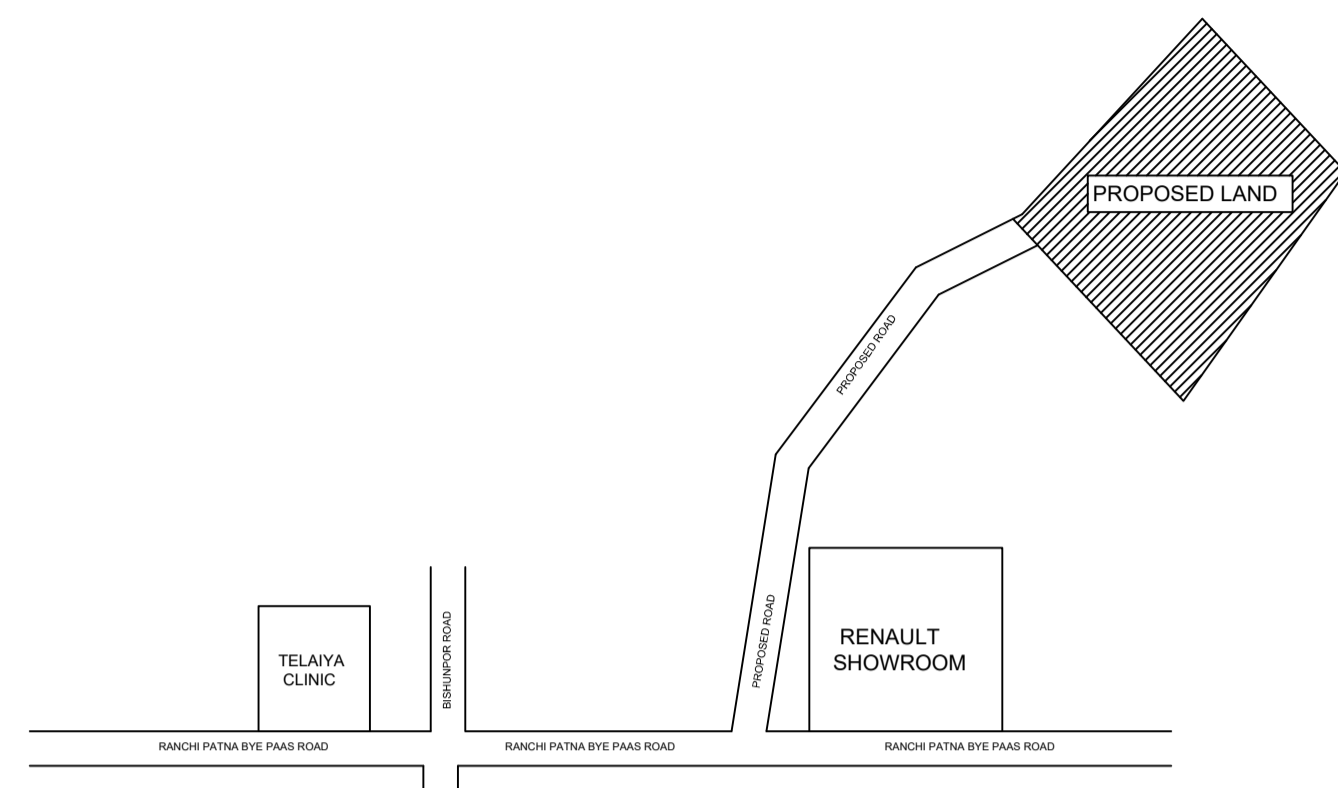

LOCATION PLAN (SCALE -1"=16')

FAR & Tenement Details (Table 4c-1)

| Building | No. of Same Bldg | Total Built Up Area (Sq.mt.) | Proposed FAR Area (Sq.mt.) Resi. | Total FAR Area (Sq.mt.) | Total Consumed Additional FAR Area (Sq.mt.) | Tnmt (No.) |
|-----------------|------------------|------------------------------|----------------------------------|-------------------------|---|------------|
| A (RESIDENTIAL) | 1 | 77.08 | 77.08 | 77.08 | 77.08 | 01 |
| Grand Total : | 1 | 77.08 | 77.08 | 77.08 | 77.08 | 01 |

Proposal Basic Information

| | |
|-------------------|------------------------------------|
| Proposal File No. | JNP/IBP/0011/W01/2020 |
| Owner Name | SMT. SARITA DEVI |
| Khata No | 1005 |
| Plot No | 4047, 4048 |
| Village Name | Tilaiya |
| Use | Residential |
| SubUse | Bungalow/ Dwelling / Non Apartment |

AREA STATEMENT

| AREA DETAILS: | | SQ.MT. |
|--|------------------|------------|
| AREA OF PLOT (Minimum) | (A) | 161.00 |
| NET AREA OF PLOT(Gross Plot Area - Deduction from Gross Plot area) | (A-Deductions) | 161.00 |
| Deduction for Balance Plot Area(from Gross Plot Area) | | |
| Common Plot | | 19.17 |
| Total | | 19.17 |
| BALANCE AREA OF PLOT(Net Plot Area - Recreational/Amenity space) | (A-Deductions) | 141.83 |
| PLOT AREA FOR COVERAGE(Net Plot Area) | (A-Deductions) | 161.00 |
| Plot Area for FAR (Net Plot Area + Road Widening Area) | (A-Deductions) | 161.00 |
| COVERAGE CHECK | | |
| Permissible Coverage area (70.00 %) | | 112.70 |
| Proposed Coverage Area (47.88 %) | | 77.08 |
| Total Prop. Coverage Area (47.88 %) | | 77.08 |
| Balance coverage area (22.12 %) | | 35.62 |
| FAR CHECK | | |
| Perm. FAR Area (1.50) | | 241.50 |
| Total Perm. FAR area | | 241.50 |
| Residential FAR | | 77.08 |
| Proposed FAR Area | | 77.08 |
| Total Proposed FAR Area | | 77.08 |
| Consumed FAR (Factor) | | 0.48 |
| Balance FAR Area | | 164.42 |
| BUILT UP AREA CHECK | | |
| Total Proposed BuiltUp Area | | 77.08 |
| ARCHITECT (Regd) | KIRAN KUMARI | |
| ENGINEER (Regd) | | |
| SUPERVISOR (Regd) | | |
| OWNER (Regd) | SMT. SARITA DEVI | |
| DEVELOPMENT AUTHORITY | | LOCAL BODY |

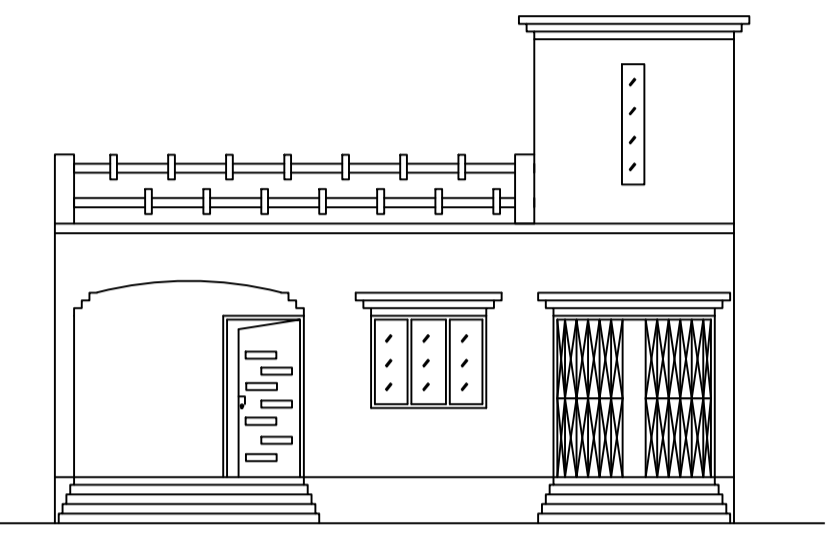

FRONT ELEVATION

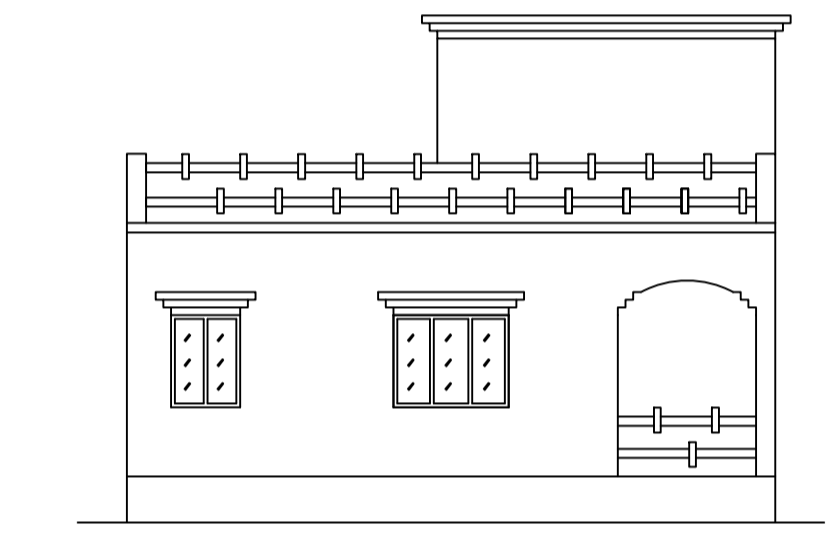

CROSS ELEVATION

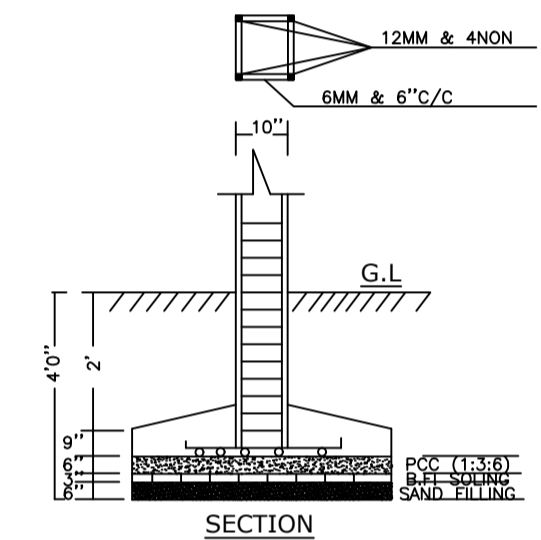

SECTION

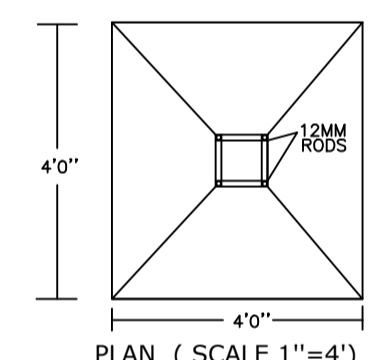

PLAN (SCALE 1"=4')

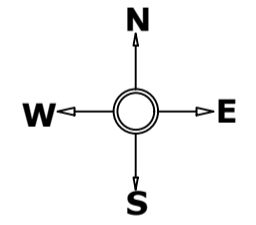

SITE PLAN

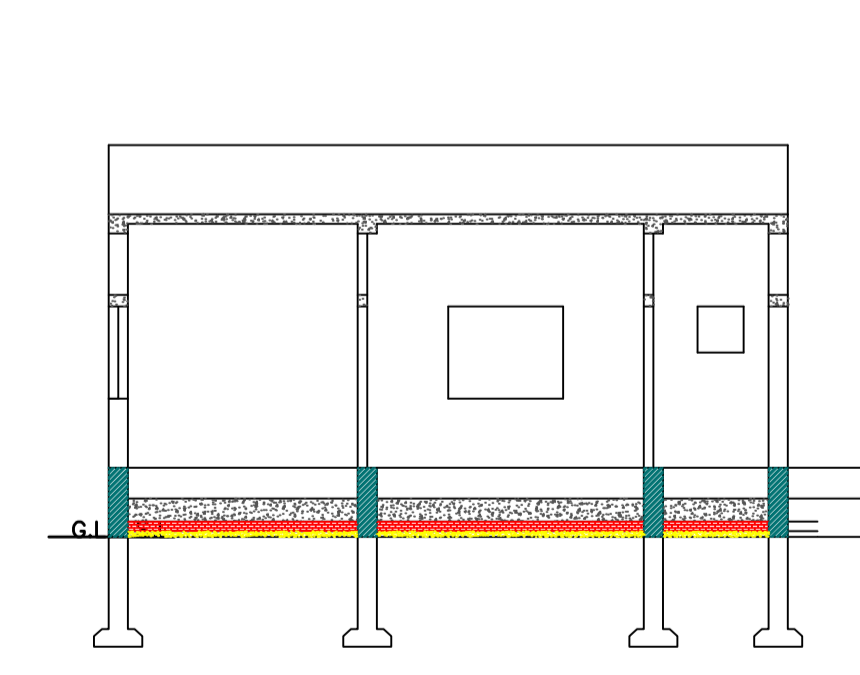

CROSS SECTION (B)

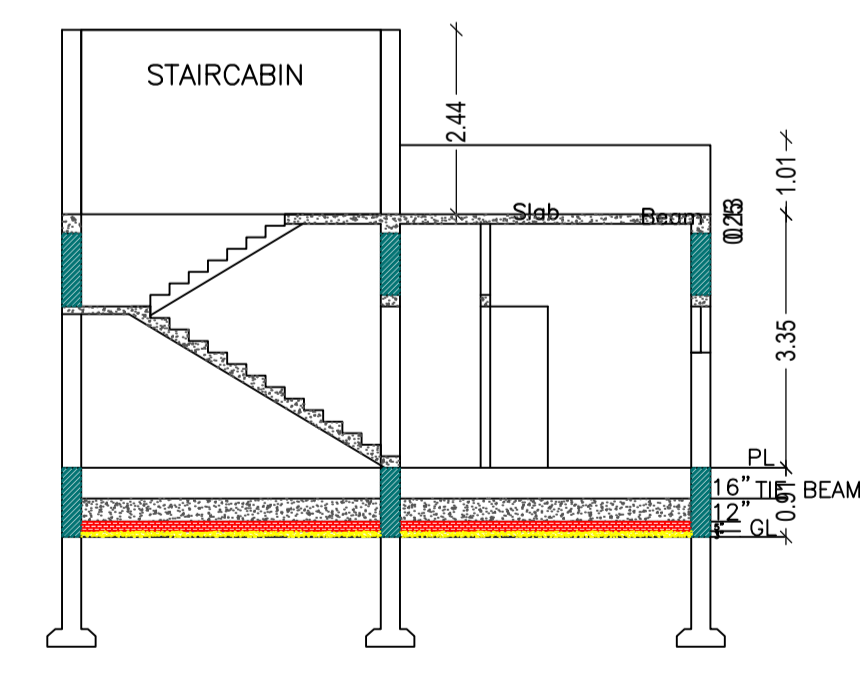

CROSS SECTION (A)

Building :A (RESIDENTIAL)

| Floor Name | Total Built Up Area (Sq.mt.) | Proposed FAR Area (Sq.mt.) Resi. | Total FAR Area (Sq.mt.) | Total Consumed Additional FAR Area (Sq.mt.) | Tnmt (No.) |
|--------------------------------|------------------------------|----------------------------------|-------------------------|---|------------|
| Ground Floor | 77.08 | 77.08 | 77.08 | 77.08 | 01 |
| Terrace Floor | 0.00 | 0.00 | 0.00 | 0.00 | 00 |
| Total : | 77.08 | 77.08 | 77.08 | 77.08 | 01 |
| Total Number of Same Buildings | 1 | | | | |
| Total : | 77.08 | 77.08 | 77.08 | 77.08 | 01 |

SCHEDULE OF DOOR:

| BUILDING NAME | NAME | LENGTH | HEIGHT | NOS |
|-----------------|------|--------|--------|-----|
| A (RESIDENTIAL) | D3 | 0.75 | 2.10 | 01 |
| A (RESIDENTIAL) | D2 | 0.90 | 2.10 | 01 |
| A (RESIDENTIAL) | D1 | 1.05 | 2.10 | 03 |

SCHEDULE OF WINDOW/VENTILATION:

| BUILDING NAME | NAME | LENGTH | HEIGHT | NOS |
|-----------------|------|--------|--------|-----|
| A (RESIDENTIAL) | V | 0.60 | 0.90 | 01 |
| A (RESIDENTIAL) | W2 | 0.90 | 1.20 | 01 |
| A (RESIDENTIAL) | W | 1.52 | 1.20 | 03 |

UnitBUA Table for Building :A (RESIDENTIAL)

| FLOOR | Name | UnitBUA Type | UnitBUA Area | Carpet Area | No. of Rooms | No. of Tenement |
|-------------------|---------|--------------|--------------|-------------|--------------|-----------------|
| GROUND FLOOR PLAN | SPLIT A | FLAT | 57.64 | 57.12 | 6 | 1 |
| Total: | - | - | 57.64 | 57.12 | 6 | 1 |

COLOR INDEX

| | |
|-----------------------------|------------|
| PLOT BOUNDARY | Black |
| ABUTTING ROAD | Green |
| PROPOSED CONSTRUCTION | Red |
| COMMON PLOT | Yellow |
| ROAD WIDENING AREA | Blue |
| EXISTING (To be retained) | Light Blue |
| EXISTING (To be demolished) | Orange |

Buildingwise Floor FAR Details

| Floor Name | Building Name A (RESIDENTIAL) | | Total | |
|---------------|---------------------------------|----------------------------|---------------------------------------|-------------------------|
| | Proposed Built Up Area (Sq.mt.) | Proposed FAR Area (Sq.mt.) | Total Proposed Built Up Area (Sq.mt.) | Total FAR Area (Sq.mt.) |
| Ground Floor | 77.08 | 77.08 | 77.08 | 77.08 |
| Terrace Floor | 0.00 | 0.00 | 0.00 | 0.00 |
| Total : | 77.08 | 77.08 | 77.08 | 77.08 |

Building USE/SUBUSE Details

| Building Name | Building Use | Building SubUse | Building Structure |
|-----------------|--------------|------------------------------------|--------------------|
| A (RESIDENTIAL) | Residential | Bungalow/ Dwelling / Non Apartment | Non-Highrise |

| LTP NAME AND SIGNATURE | STRUCTURAL ENG'S NAME AND SIGNATURE | BUILDER NAME AND SIGNATURE | DIGITAL SIGNATURE |
|-----------------------------------|-------------------------------------|----------------------------|-------------------|
| KIRAN KUMARI JNP/ENG/0011/2019 | | | |