

SITE PLAN

FAR & Tenement Details (Table 4c-1)

Building	No. of Same Bldg	Total Built Up Area (Sq.mt.)	Deductions (Area in Sq.mt.)		Proposed FAR Area (Sq.mt.)	Total FAR Area (Sq.mt.)	Total Consumed Additional FAR Area (Sq.mt.)	Trnmt (No.)
			Archi.Proj.	Resi.				
A (RESIDENTIAL)	1	241.94	11.82		230.12	230.12	230.12	01
<b>Grand Total :</b>	<b>1</b>	<b>241.94</b>	<b>11.82</b>		<b>230.12</b>	<b>230.12</b>	<b>230.12</b>	<b>01</b>

Proposal Basic Information

Proposal File No.	JNP/IBP/0029/W01/2020
Owner Name	SMT. KANCHAN YADAV
Khata No	1179
Plot No	3829, 3832
Village Name	Tilaiya
Use	Residential
SubUse	Bungalow/ Dwelling / Non Apartment

AREA STATEMENT	VERSION NO. : 1.0.46
JHUMRITILAIYA NAGAR PARISHAD	VERSION DATE: 22/06/2020
PROJECT DETAIL:	
Region: JHARKHAND URBAN LOCAL BODIES	Plot Use: Residential
District: KODERMA	Plot SubUse: Bungalow/ Dwelling / Non Apartment
Authority: JHUMRITILAIYA NAGAR PARISHAD	PlotNearbyReligiousStructure: NA
Inward No: JNP/IBP/0029/W01/2020	PlotSubPlot No: 3829, 3832
Application Type: General Proposal	North: Road Width - 6.4
Project Type: Building Permission	South: Plot No. - SMT PRIYA BHARTI
Nature of Development: New	East: Plot No. - 3831,3833
Location of Development Area: Old Area	West: Plot No. - NALA AND SMT. SHASHIBALA SINGH
AREA DETAILS:	
AREA OF PLOT (Minimum)	(A) 281.16
NET AREA OF PLOT(Gross Plot Area - Deduction from Gross Plot area)	(A-Deductions) 281.16
Deduction for Balance Plot Area(from Gross Plot Area)	
Common Plot	25.62
Total	25.62
BALANCE AREA OF PLOT(Net Plot Area - Recreational/Amenity space)	(A-Deductions) 255.54
PLOT AREA FOR COVERAGE(Net Plot Area)	(A-Deductions) 281.16
Plot Area for FAR (Net Plot Area + RoadWidening Area)	(A-Deductions) 281.16
COVERAGE CHECK	
Permissible Coverage area ( 60.00 % )	168.70
Proposed Coverage Area ( 38.42 % )	108.02
Total Prop. Coverage Area ( 38.42 % )	108.02
Balance coverage area ( 21.58 % )	60.68
FAR CHECK	
Perm. FAR Area ( 2.00 )	562.32
Total Perm. FAR area	562.32
Residential FAR	230.12
Proposed FAR Area	230.12
Total Proposed FAR Area	230.12
Consumed FAR (Factor)	0.82
Balance FAR Area	332.20
BUILT UP AREA CHECK	
Total Proposed BuiltUp Area	241.94
ARCHITECT (Regd)	KIRAN KUMARI
ENGINEER (Regd)	
SUPERVISOR (Regd)	
OWNER (Regd)	SMT. KANCHAN YADAV
DEVELOPMENT AUTHORITY	
	LOCAL BODY

COLOR INDEX	
PLOT BOUNDARY	Black
ABUTTING ROAD	Green
PROPOSED CONSTRUCTION	Red
COMMON PLOT	Yellow
ROAD WIDENING AREA	Blue
EXISTING (To be retained)	Blue
EXISTING (To be demolished)	Yellow

Buildingwise Floor FAR Details

Floor Name	Building Name A (RESIDENTIAL)		Total	
	Proposed Built Up Area (Sq.mt.)	Proposed FAR Area (Sq.mt.)	Total Proposed Built Up Area (Sq.mt.)	Total FAR Area (Sq.mt.)
Ground Floor	119.84	108.02	119.84	108.02
First Floor	122.10	122.10	122.10	122.10
Terrace Floor	0.00	0.00	0.00	0.00
<b>Total :</b>	<b>241.94</b>	<b>230.12</b>	<b>241.94</b>	<b>230.12</b>

Building USE/SUBUSE Details

Building Name	Building Use	Building SubUse	Building Structure
A (RESIDENTIAL)	Residential	Bungalow/ Dwelling / Non Apartment	Non-Highrise

LTP NAME AND SIGNATURE	STRUCTURAL ENG'S NAME AND SIGNATURE	BUILDER NAME AND SIGNATURE	DIGITAL SIGNATURE
KIRAN KUMARI JNP/ENG/0001/2019			

Proposal Basic Information	
Proposal File No.	JNP/EP/0029/W01/2020
Owner Name	SMT. KANCHAN YADAV
Khata No	1179
Plot No	3829, 3832
Village Name	Tilaiya
Use	Residential
SubUse	Bungalow/ Dwelling / Non Apartment

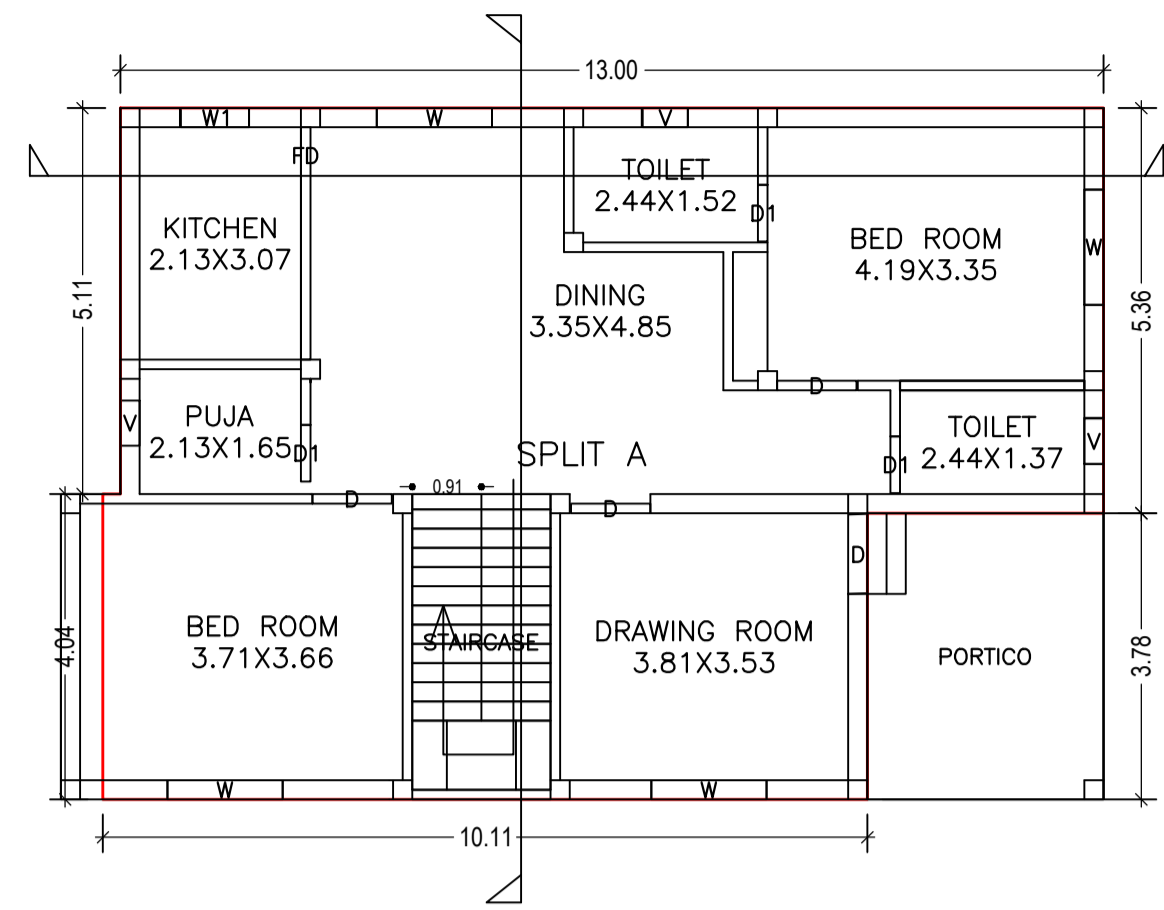

GROUND FLOOR PLAN (Proposed) (SCALE 1:100)

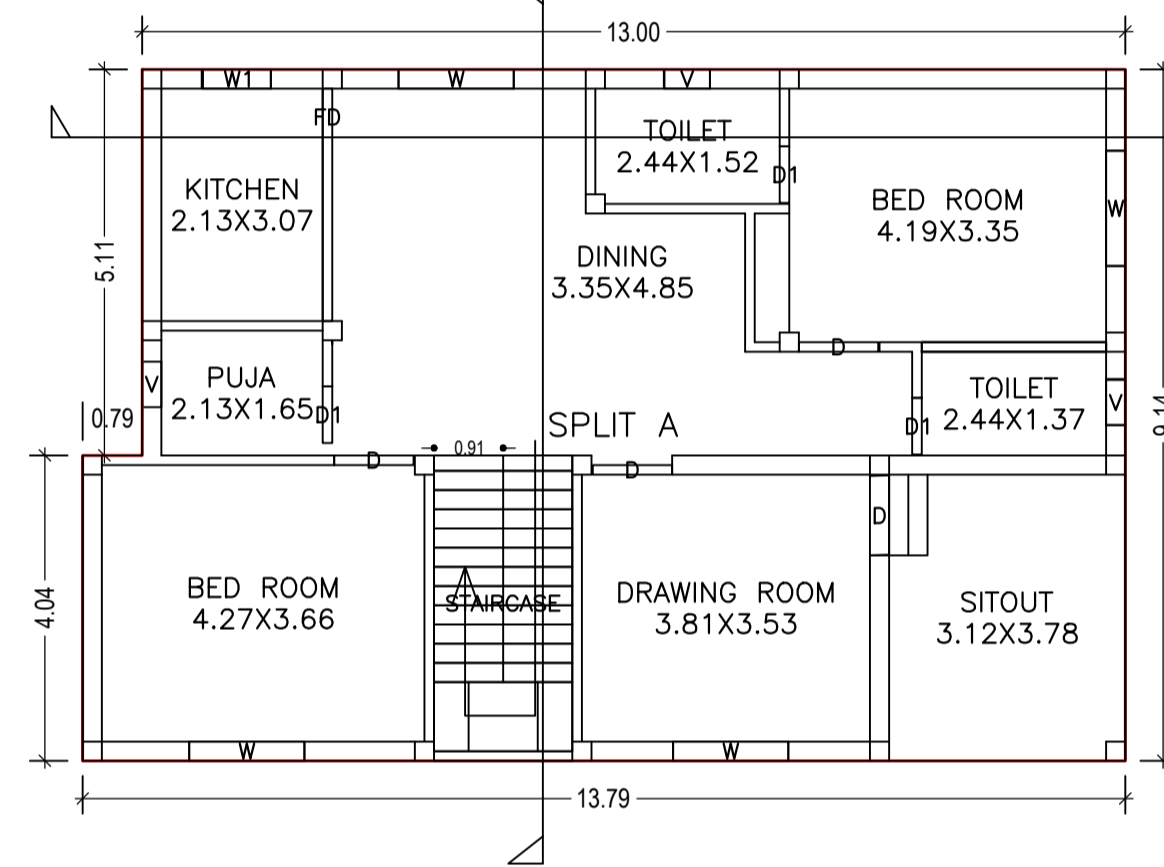

FIRST FLOOR PLAN (Proposed) (SCALE 1:100)

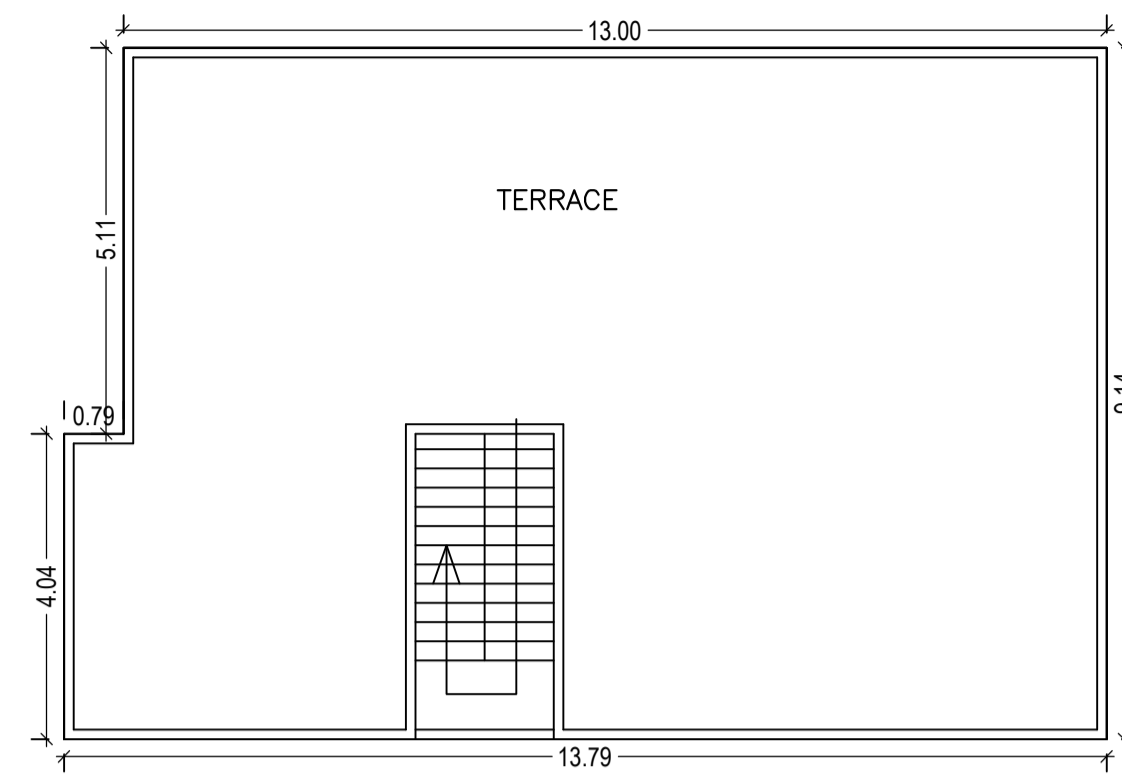

TERRACE FLOOR PLAN (SCALE 1:100)

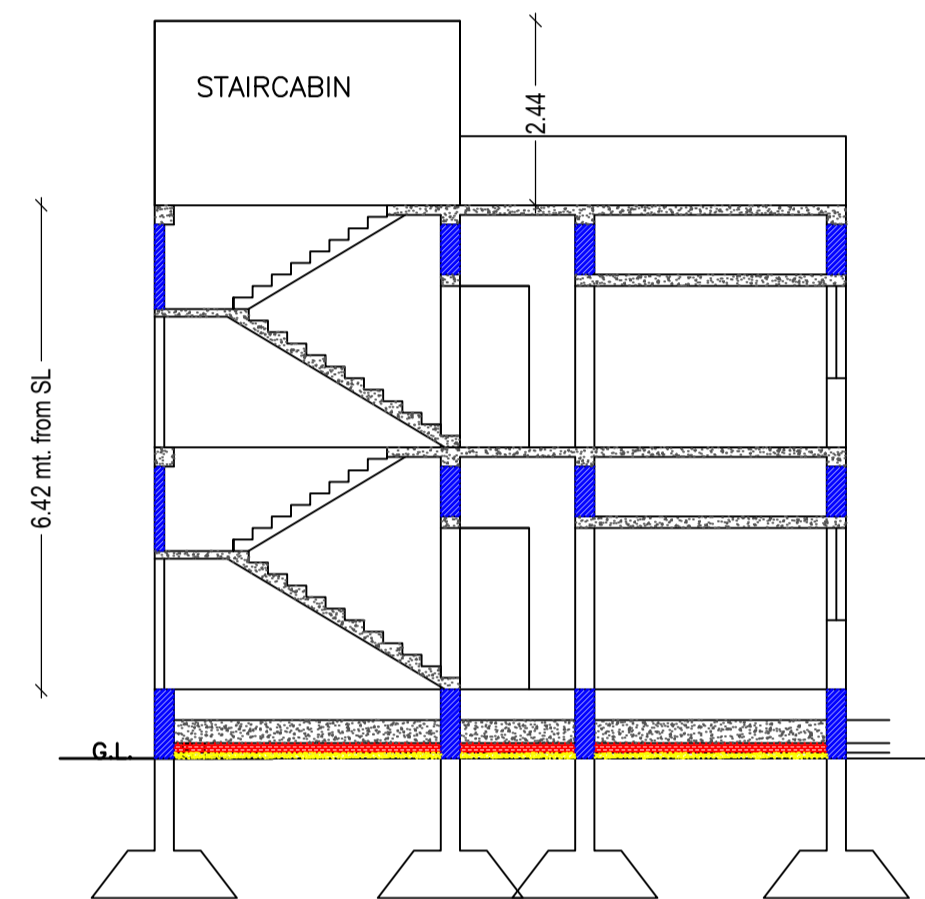

CROSS SECTION (A)

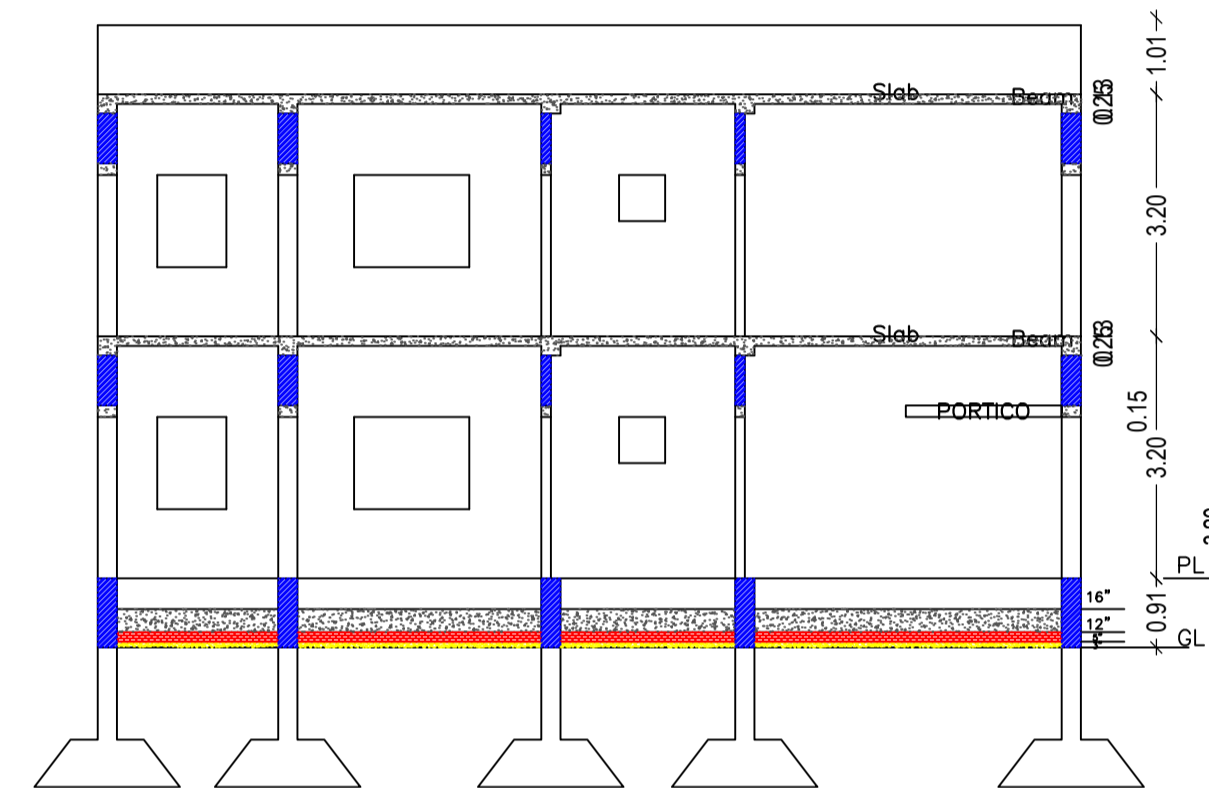

CROSS SECTION (B)

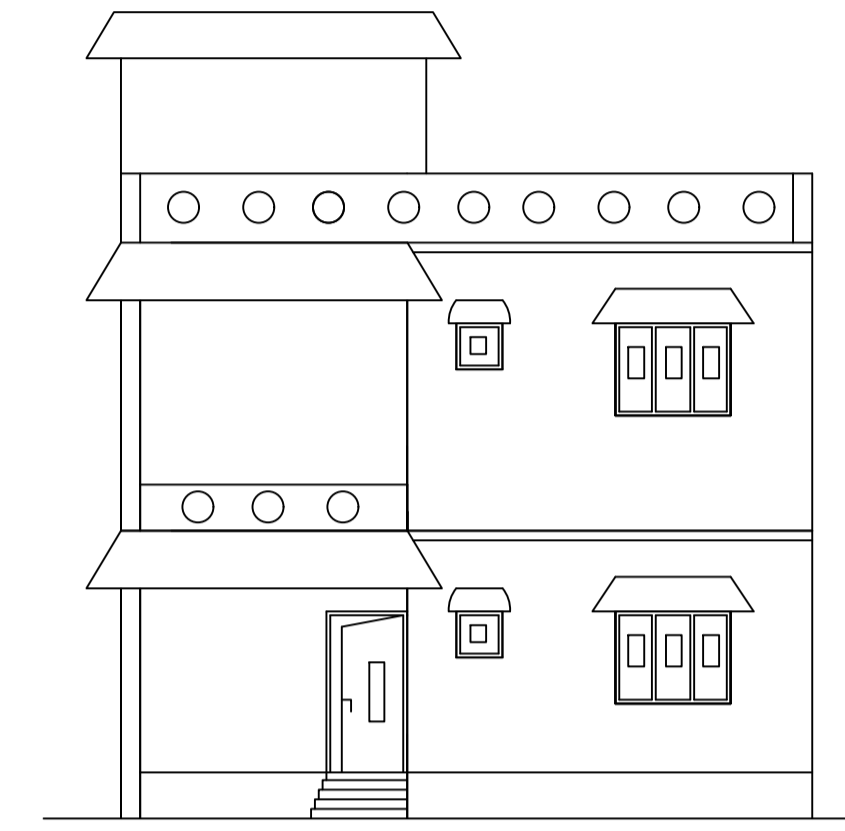

CROSS ELEVATION

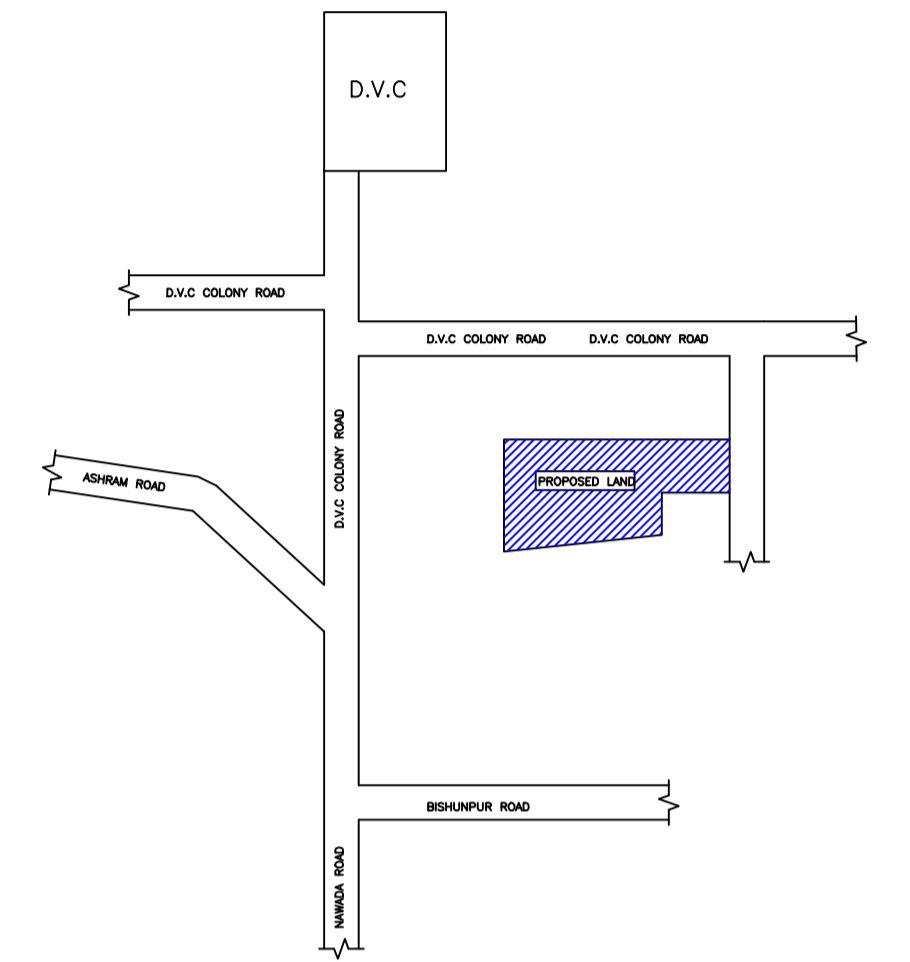

LOCATION PLAN (SCALE -1''=16')

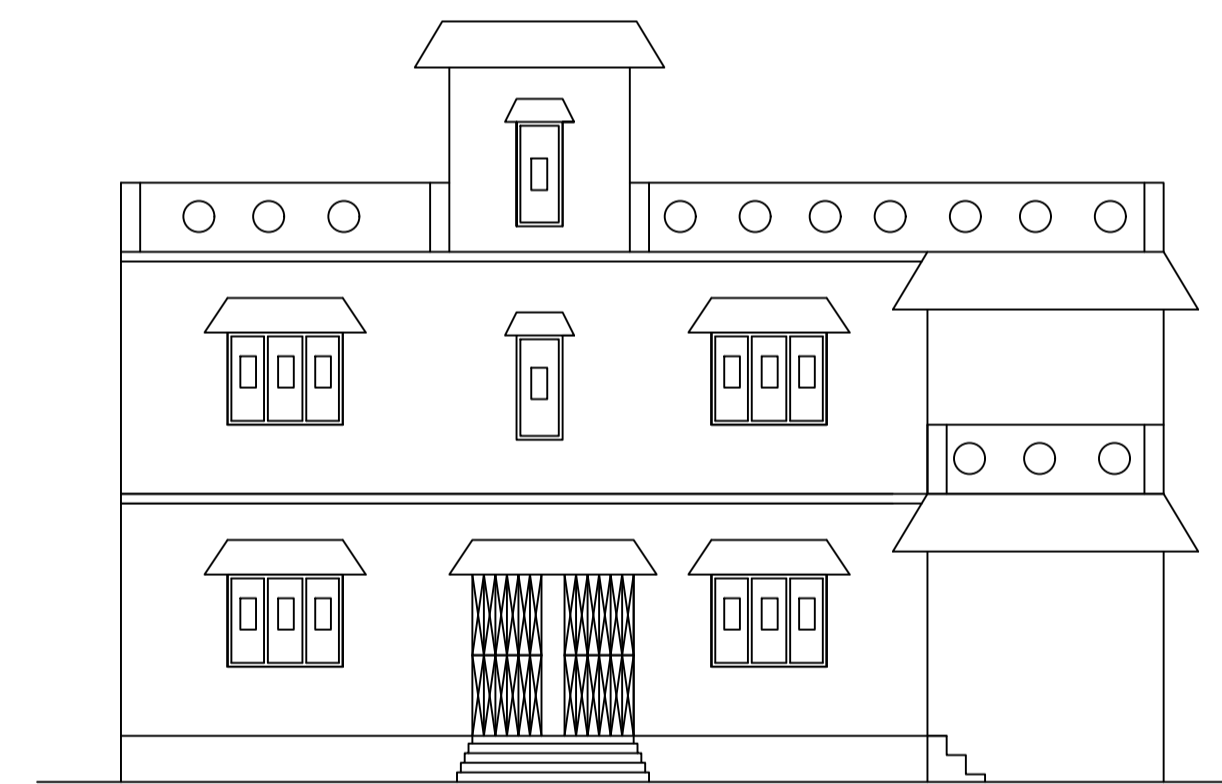

FRONT ELEVATION

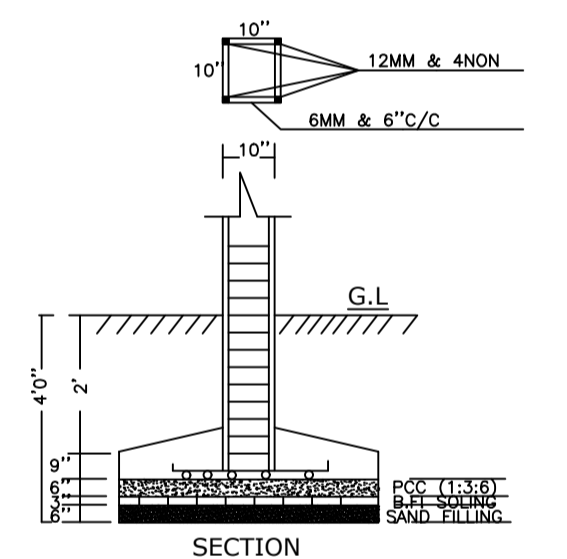

SECTION

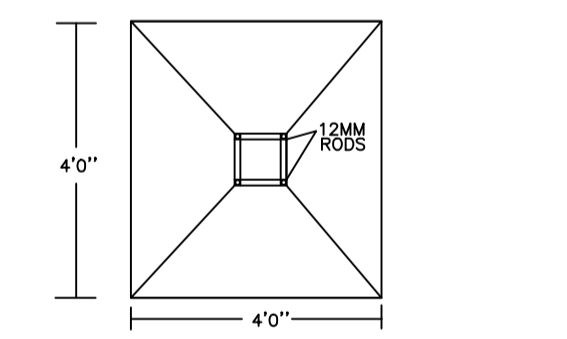

PLAN (SCALE 1''=4')

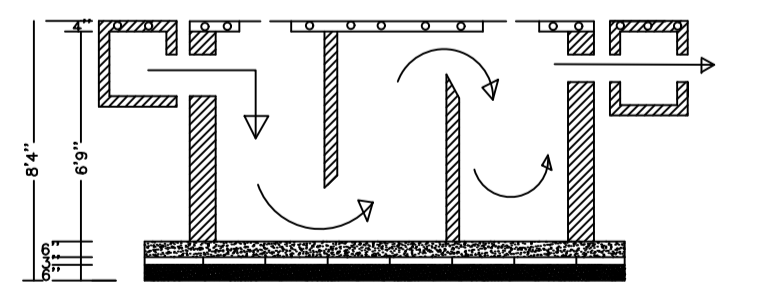

SECTION

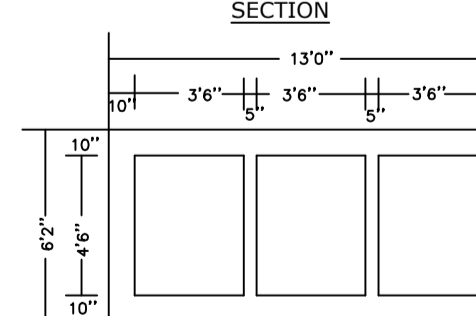

PLAN OF SEPTIK TANK

Building :A (RESIDENTIAL)

Floor Name	Total Built Up Area (Sq.mt.)	Deductions (Area in Sq.mt.)	Proposed FAR Area (Sq.mt.)	Total FAR Area (Sq.mt.)	Total Consumed Additional FAR Area (Sq.mt.)	Trmt (No.)
Ground Floor	119.84	11.82	108.02	108.02	108.02	01
First Floor	122.10	0.00	122.10	122.10	122.10	00
Terrace Floor	0.00	0.00	0.00	0.00	0.00	00
Total :	241.94	11.82	230.12	230.12	230.12	01
Total Number of Same Buildings	1					
Total :	241.94	11.82	230.12	230.12	230.12	01

SCHEDULE OF DOOR:

BUILDING NAME	NAME	LENGTH	HEIGHT	NOS
A (RESIDENTIAL)	D1	0.75	2.10	06
A (RESIDENTIAL)	D	1.05	2.10	08
A (RESIDENTIAL)	FD	3.07	2.10	02

SCHEDULE OF WINDOW/VENTILATION:

BUILDING NAME	NAME	LENGTH	HEIGHT	NOS
A (RESIDENTIAL)	V	0.60	0.90	06
A (RESIDENTIAL)	W1	0.90	1.20	02
A (RESIDENTIAL)	W	1.52	1.20	08

UnitBUA Table for Building :A (RESIDENTIAL)

FLOOR	Name	UnitBUA Type	UnitBUA Area	Carpet Area	No. of Rooms	No. of Tenement
GROUND FLOOR PLAN	SPLIT A	FLAT	193.67	193.05	8	1
FIRST FLOOR PLAN	SPLIT A	FLAT	0.00	0.00	9	0
Total:	-	-	193.67	193.05	17	1

LTP NAME AND SIGNATURE	STRUCTURAL ENG'S NAME AND SIGNATURE	BUILDER NAME AND SIGNATURE	DIGITAL SIGNATURE
KIRAN KUMARI JNP/ENG/0001/2019			