

SITE PLAN

FAR & Tenement Details (Table 4c-1)

Building	No. of Same Bldg	Total Built Up Area (Sq.mt.)	Deductions (Area in Sq.mt.)		Proposed FAR Area (Sq.mt.)	Add Area In FAR (Sq.mt.)	Total FAR Area (Sq.mt.)	Total Consumed Additional FAR Area (Sq.mt.)	Tenmt (No.)
			Parking	Resi.					
A (RESIDENTIAL)	1	134.86	28.82	95.75	10.29	106.04	106.04	01	
Grand Total :	1	134.86	28.82	95.75	10.29	106.04	106.04	01	

Proposal Basic Information

Proposal File No.	JNP/IBP/0020/W13/2020
Owner Name	MUNNI DEVI
Khata No	1035
Plot No	6879
Village Name	Tilaiya
Use	Residential
SubUse	Bungalow/ Dwelling / Non Apartment

AREA STATEMENT	VERSION NO. : 1.0.46
JHUMRITILAIYA NAGAR PARISHAD	VERSION DATE: 22/06/2020
PROJECT DETAIL:	
Region: JHARKHAND URBAN LOCAL BODIES	Plot Use: Residential
District: KODERMA	Plot SubUse: Bungalow/ Dwelling / Non Apartment
Authority: JHUMRITILAIYA NAGAR PARISHAD	PlotNearbyReligiousStructure: NA
Inward No: JNP/IBP/0020/W13/2020	Plot/SubPlot No: 6879
Application Type: General Proposal	North: Road Width - 4.5
Project Type: Building Permission	South: Plot No. - SRI MANISH KUMAR
Nature of Development: New	East: Road Width - 4.5
Location of Development Area: Old Area	West: Plot No. - MANDIR
AREA DETAILS:	
AREA OF PLOT (Minimum)	(A) 71.26
NET AREA OF PLOT(Gross Plot Area - Deduction from Gross Plot area)	(A-Deductions) 71.26
Deduction for Balance Plot Area(from Gross Plot Area)	
Common Plot	5.21
Total	5.21
BALANCE AREA OF PLOT(Net Plot Area - Recreational/Amenity space)	(A-Deductions) 66.05
PLOT AREA FOR COVERAGE(Net Plot Area)	(A-Deductions) 71.26
Plot Area for FAR (Net Plot Area + RoadWidening Area)	(A-Deductions) 71.26
COVERAGE CHECK	
Permissible Coverage area (70.00 %)	49.88
Proposed Coverage Area (60.57 %)	43.16
Total Prop. Coverage Area (60.57 %)	43.16
Balance coverage area (9.43 %)	6.72
FAR CHECK	
Perm. FAR Area (1.50)	106.89
Total Perm. FAR area	106.89
Residential FAR	95.75
Proposed FAR Area	106.04
Total Proposed FAR Area	106.04
Consumed FAR (Factor)	1.49
Balance FAR Area	0.85
BUILT UP AREA CHECK	
Total Proposed BuiltUp Area	134.86
ARCHITECT (Regd)	KIRAN KUMARI
ENGINEER (Regd)	
SUPERVISOR (Regd)	
OWNER (Regd)	MUNNI DEVI
DEVELOPMENT AUTHORITY	
	LOCAL BODY

COLOR INDEX	
PLOT BOUNDARY	Black
ABUTTING ROAD	Green
PROPOSED CONSTRUCTION	Red
COMMON PLOT	Yellow
ROAD WIDENING AREA	Light Yellow
EXISTING (To be retained)	Blue
EXISTING (To be demolished)	Light Blue

Buildingwise Floor FAR Details

Floor Name	Building Name		Total	
	Proposed Built Up Area (Sq.mt.)	Proposed FAR Area (Sq.mt.)	Total Proposed Built Up Area (Sq.mt.)	Total FAR Area (Sq.mt.)
Ground Floor	43.16	14.34	43.16	14.34
First Floor	45.85	45.85	45.85	45.85
Second Floor	45.85	45.85	45.85	45.85
Terrace Floor	0.00	0.00	0.00	0.00
Total :	134.86	106.04	134.86	106.04

Building USE/SUBUSE Details

Building Name	Building Use	Building SubUse	Building Structure
A (RESIDENTIAL)	Residential	Bungalow/ Dwelling / Non Apartment	Non-Highrise

LTP NAME AND SIGNATURE	STRUCTURAL ENG'S NAME AND SIGNATURE	BUILDER NAME AND SIGNATURE	DIGITAL SIGNATURE
KIRAN KUMARI JNP/ENG/001/2019			

Proposal Basic Information	
Proposal File No.	JNP/IBP/0020/W13/2020
Owner Name	MUNNI DEVI
Khata No	1035
Plot No	6879
Village Name	Tilaiya
Use	Residential
SubUse	Bungalow/ Dwelling / Non Apartment

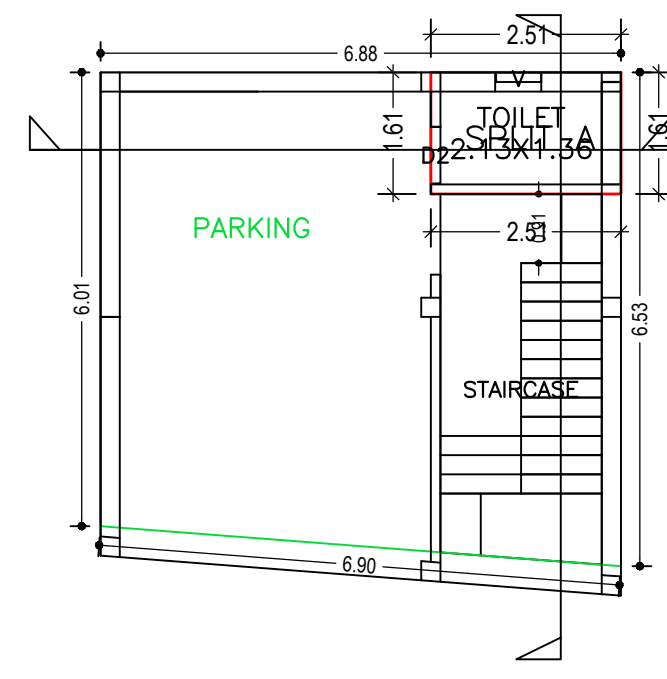

GROUND FLOOR PLAN (Proposed) (SCALE 1:100)

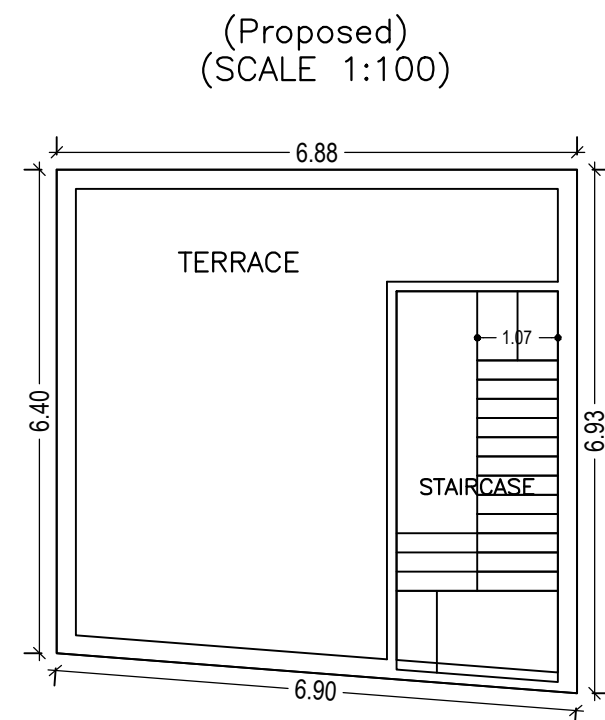

TERRACE FLOOR PLAN (SCALE 1:100)

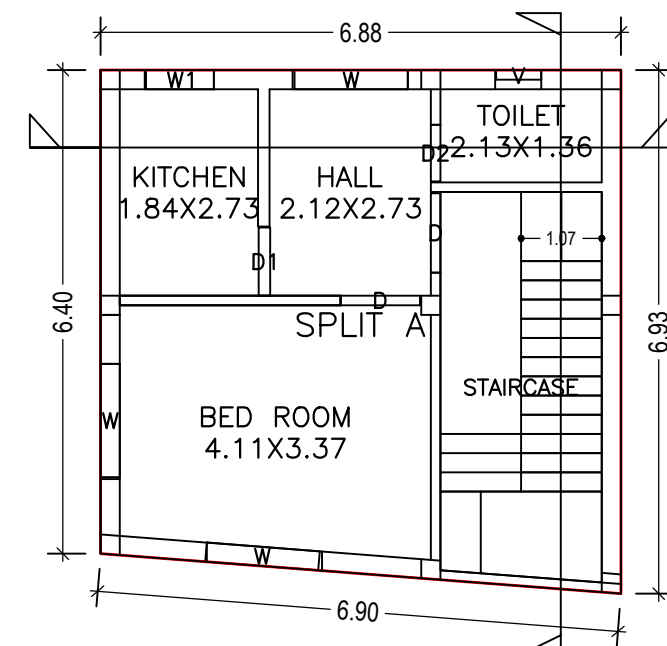

FIRST FLOOR PLAN (Proposed) (SCALE 1:100)

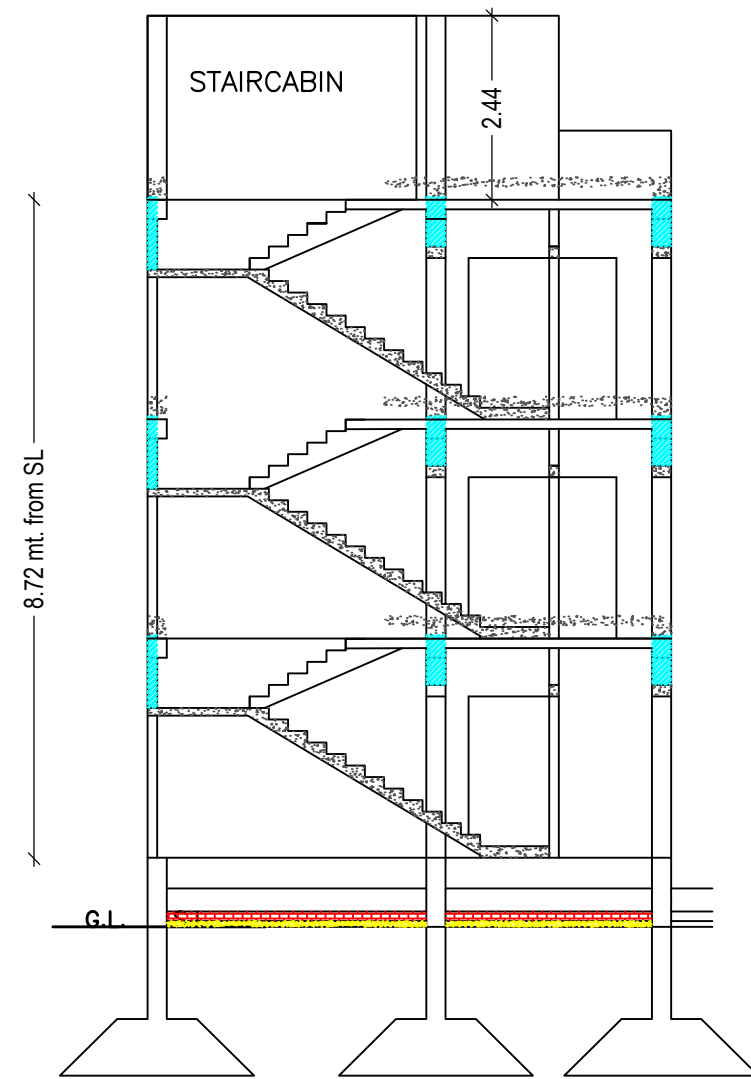

CROSS SECTION (A)

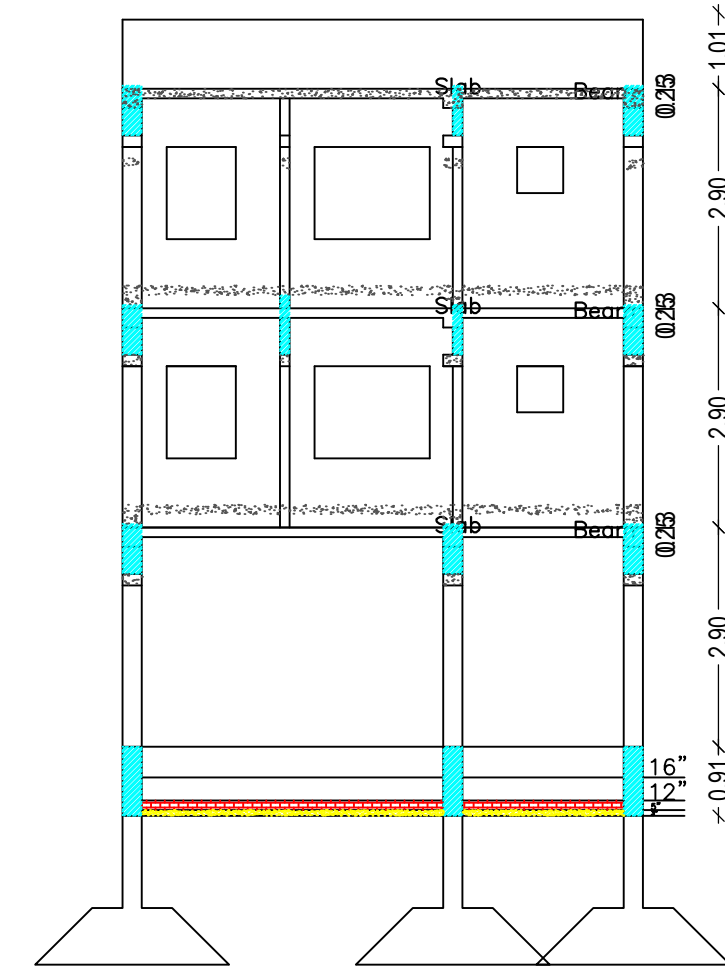

CROSS SECTION (B)

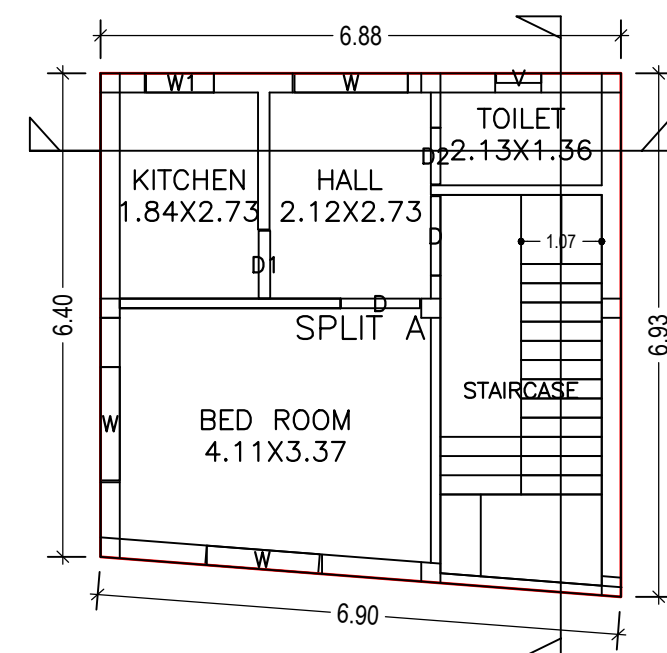

SECOND FLOOR PLAN (Proposed) (SCALE 1:100)

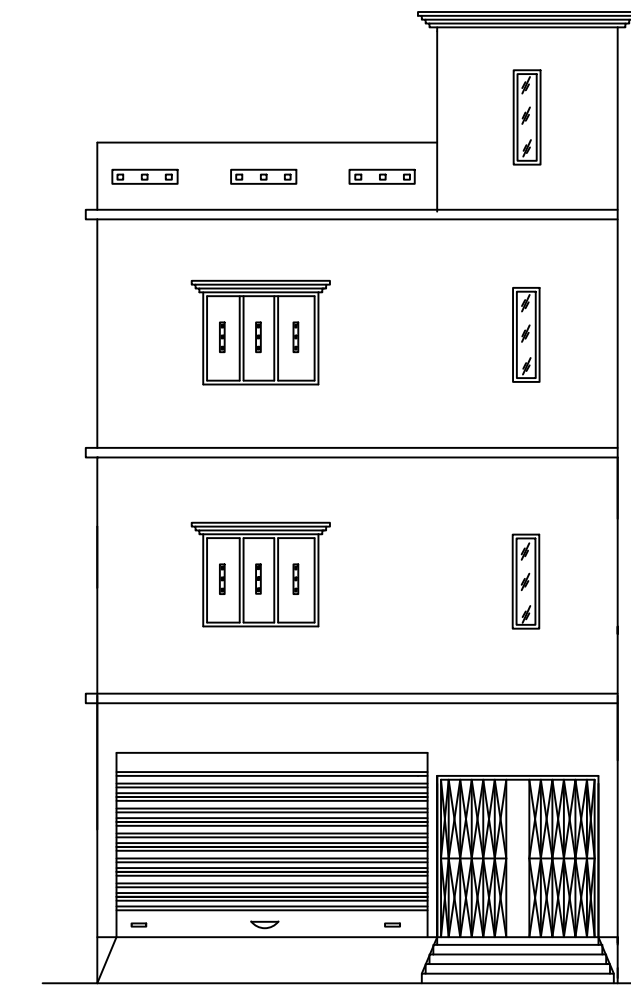

FRONT ELEVATION

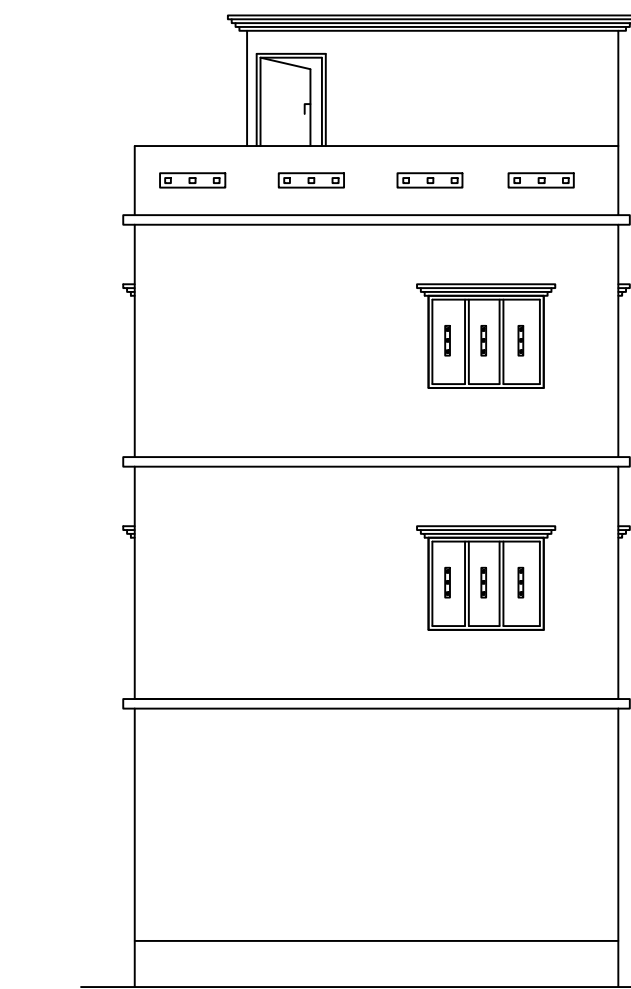

CROSS ELEVATION

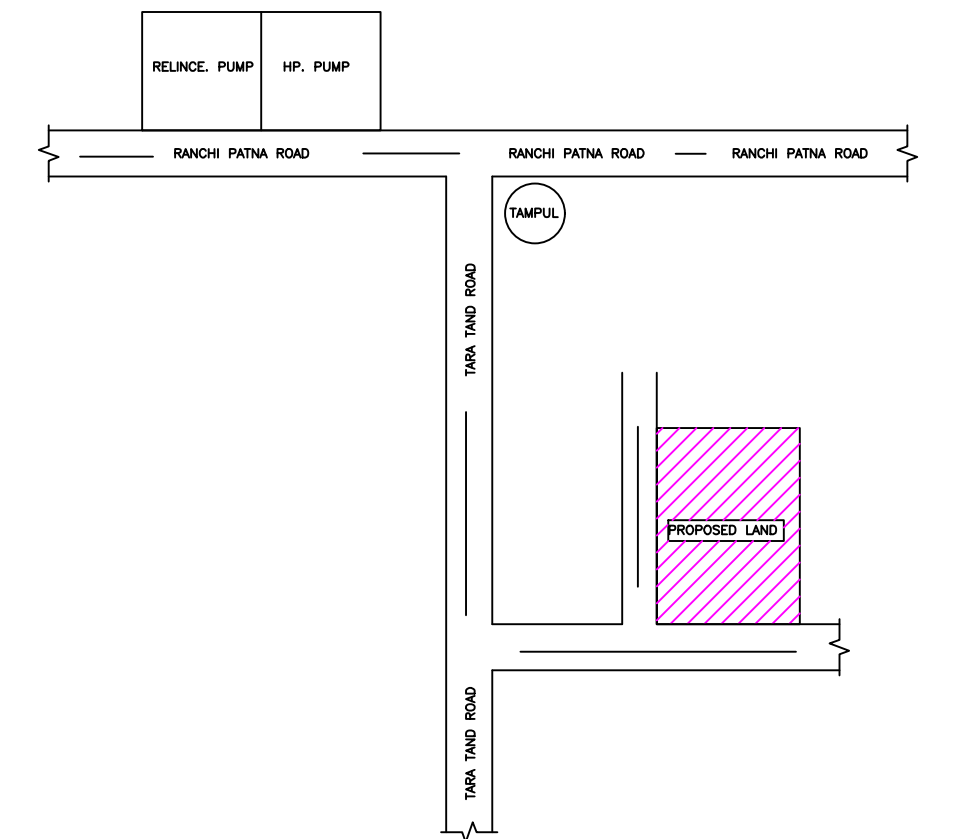

LOCATION PLAN (SCALE -1''16'')

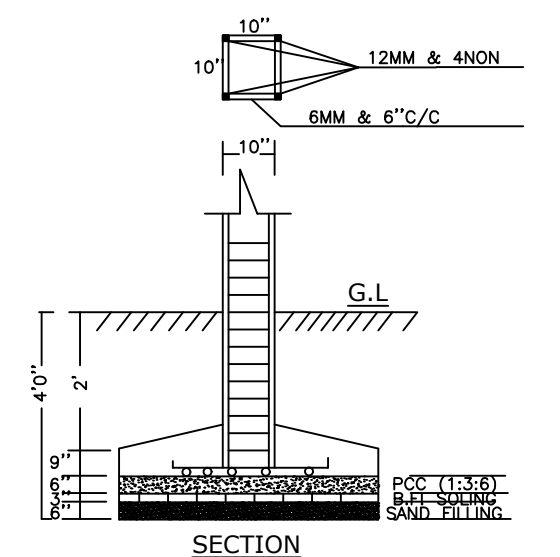

SECTION

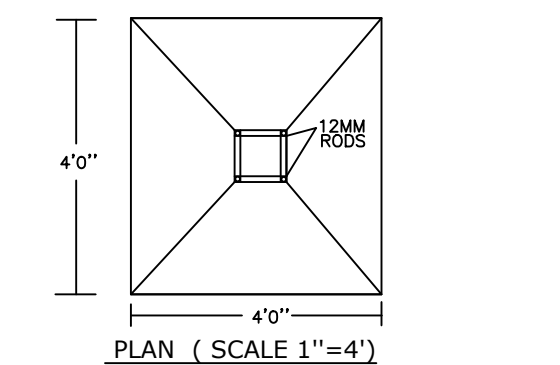

PLAN (SCALE 1''=4'')

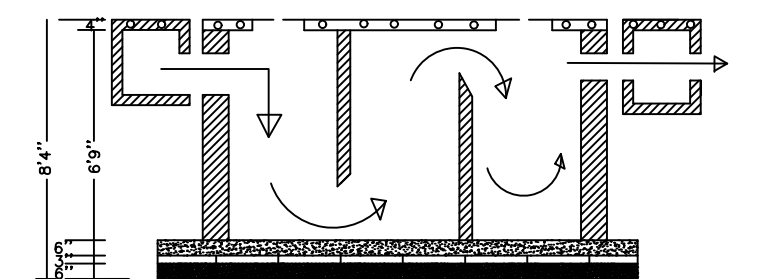

SECTION

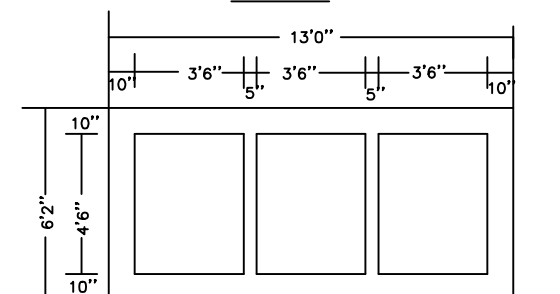

PLAN OF SEPTIK TANK

Building :A (RESIDENTIAL)

Floor Name	Total Built Up Area (Sq.mt.)	Deductions (Area in Sq.mt.)		Proposed FAR Area (Sq.mt.)	Add Area in FAR (Sq.mt.)		Total FAR Area (Sq.mt.)	Total Consumed Additional FAR Area (Sq.mt.)	Trmt (No.)
		Parking	Resi.		Stair				
Ground Floor	43.16	28.82	4.05	10.29	14.34	14.34	01		
First Floor	45.85	0.00	45.85	0.00	45.85	45.85	00		
Second Floor	45.85	0.00	45.85	0.00	45.85	45.85	00		
Terrace Floor	0.00	0.00	0.00	0.00	0.00	0.00	00		
Total :	134.86	28.82	95.75	10.29	106.04	106.04	01		
Total Number of Same Buildings	1								
Total :	134.86	28.82	95.75	10.29	106.04	106.04	01		

SCHEDULE OF DOOR:

BUILDING NAME	NAME	LENGTH	HEIGHT	NOS
A (RESIDENTIAL)	D2	0.75	2.10	03
A (RESIDENTIAL)	D1	0.90	2.10	02
A (RESIDENTIAL)	D	1.05	2.10	04

SCHEDULE OF WINDOW/VENTILATION:

BUILDING NAME	NAME	LENGTH	HEIGHT	NOS
A (RESIDENTIAL)	V	0.60	0.90	03
A (RESIDENTIAL)	W1	0.90	1.20	02
A (RESIDENTIAL)	W	1.50	1.20	06

UnitBUA Table for Building :A (RESIDENTIAL)

FLOOR	Name	UnitBUA Type	UnitBUA Area	Carpet Area	No. of Rooms	No. of Tenement
GROUND FLOOR PLAN	SPLIT A	FLAT	59.26	58.17	1	1
FIRST FLOOR PLAN	SPLIT A	FLAT	0.00	0.00	4	0
SECOND FLOOR PLAN	SPLIT A	FLAT	0.00	0.00	4	0
Total:	-	-	59.26	58.17	9	1

LTP NAME AND SIGNATURE	STRUCTURAL ENG'S NAME AND SIGNATURE	BUILDER NAME AND SIGNATURE	DIGITAL SIGNATURE
KIRAN KUMARI JNP/ENG/0001/2019			