

SITE PLAN

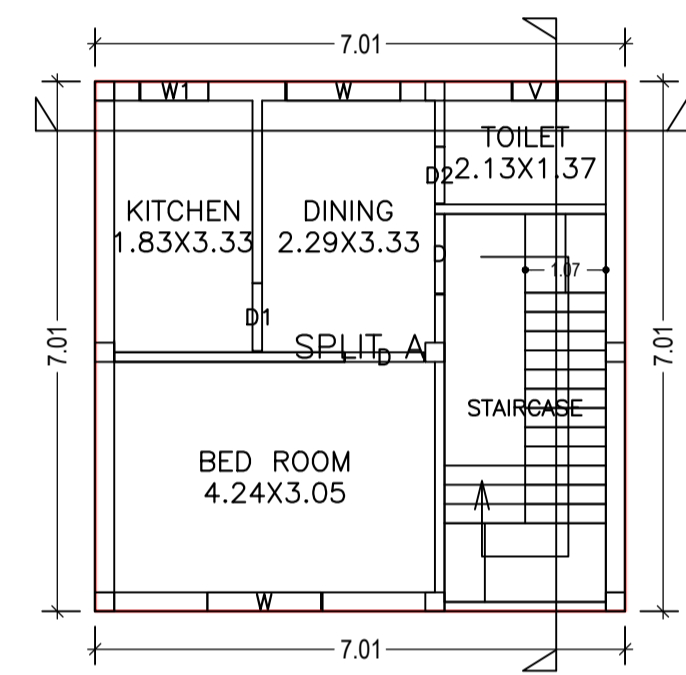

GROUND FLOOR PLAN (Proposed) (SCALE 1:100)

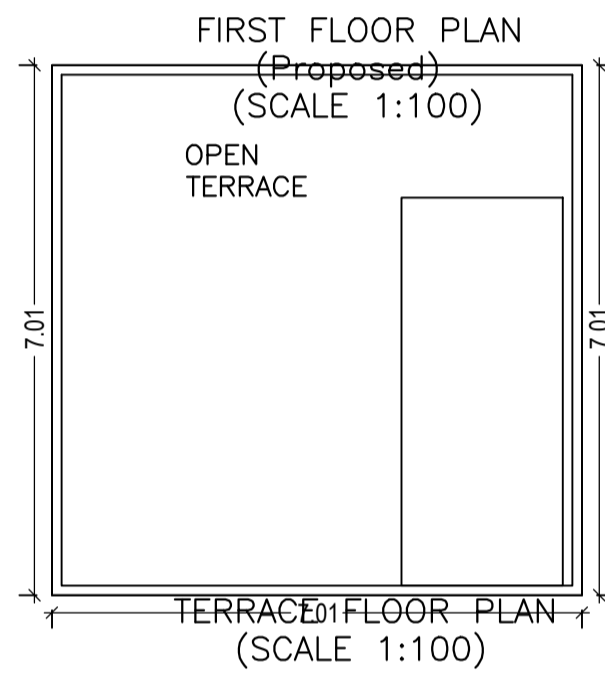

FIRST FLOOR PLAN (Proposed) (SCALE 1:100)

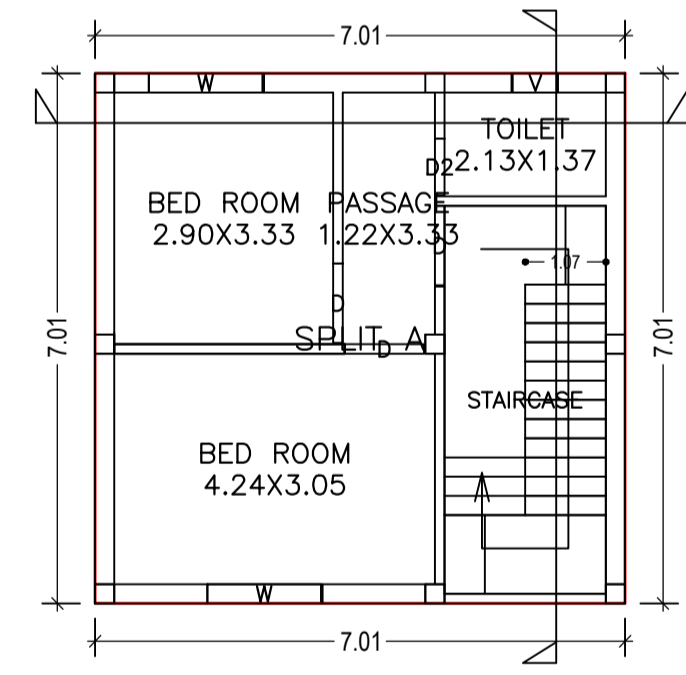

FIRST FLOOR PLAN (Proposed) (SCALE 1:100)

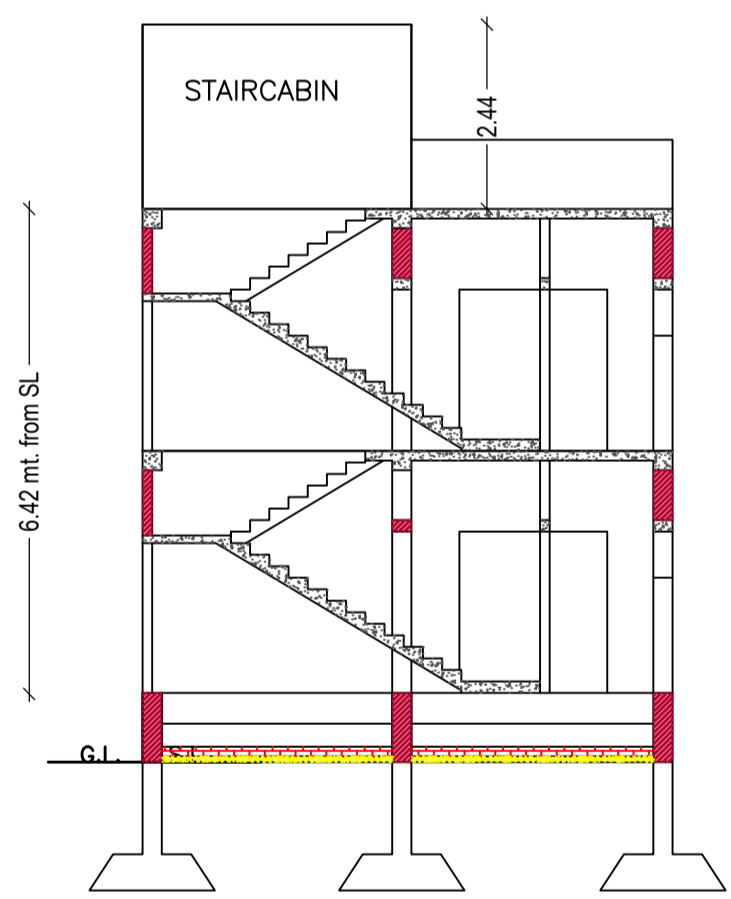

CROSS SECTION (A)

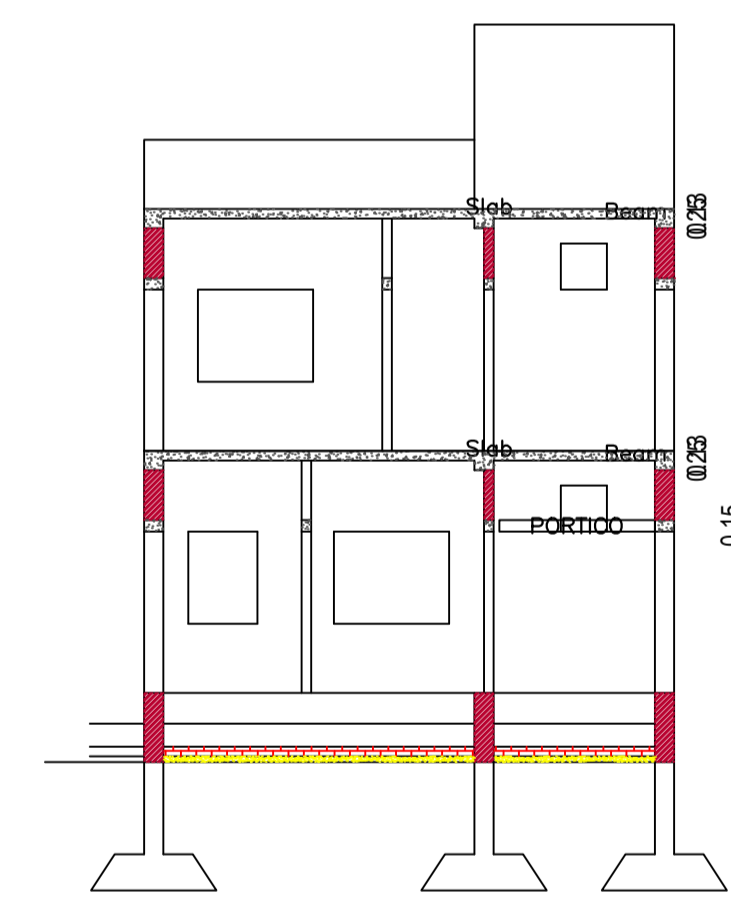

CROSS SECTION (B)

Building :A (RESIDENTIAL)

Floor Name	Total Built Up Area (Sq.mt.)	Proposed FAR Area (Sq.mt.) Resi.	Total FAR Area (Sq.mt.)	Total Consumed Additional FAR Area (Sq.mt.)	Tnmt (No.)
Ground Floor	49.15	49.15	49.15	49.15	01
First Floor	49.15	49.15	49.15	49.15	00
Terrace Floor	0.00	0.00	0.00	0.00	00
Total :	98.30	98.30	98.30	98.30	01
Total Number of Same Buildings	1				
Total :	98.30	98.30	98.30	98.30	01

SCHEDULE OF DOOR:

BUILDING NAME	NAME	LENGTH	HEIGHT	NOS
A (RESIDENTIAL)	D2	0.75	2.10	02
A (RESIDENTIAL)	D1	0.90	2.10	01
A (RESIDENTIAL)	D	1.05	2.10	05

SCHEDULE OF WINDOW/VENTILATION:

BUILDING NAME	NAME	LENGTH	HEIGHT	NOS
A (RESIDENTIAL)	V	0.60	0.90	02
A (RESIDENTIAL)	W1	0.90	1.20	01
A (RESIDENTIAL)	W	1.50	1.20	04

UnitBUA Table for Building :A (RESIDENTIAL)

FLOOR	Name	UnitBUA Type	UnitBUA Area	Carpet Area	No. of Rooms	No. of Tenement
GROUND FLOOR PLAN	SPLIT A	FLAT	61.37	60.59	4	1
FIRST FLOOR PLAN	SPLIT A	FLAT	0.00	0.00	4	0
Total:	-	-	61.37	60.59	8	1

FAR & Tenement Details (Table 4c-1)

Building	No. of Same Bldg	Total Built Up Area (Sq.mt.)	Proposed FAR Area (Sq.mt.) Resi.	Total FAR Area (Sq.mt.)	Total Consumed Additional FAR Area (Sq.mt.)	Tnmt (No.)
A (RESIDENTIAL)	1	98.30	98.30	98.30	98.30	01
Grand Total :	1	98.30	98.30	98.30	98.30	01

Proposal Basic Information

Proposal File No.	JNP/BI/0021/W/10/2020
Owner Name	MAMTA DEVI JAIN
Khata No	631
Plot No	7459
Village Name	Tilaiya
Use	Residential
SubUse	Bungalow/ Dwelling / Non Apartment

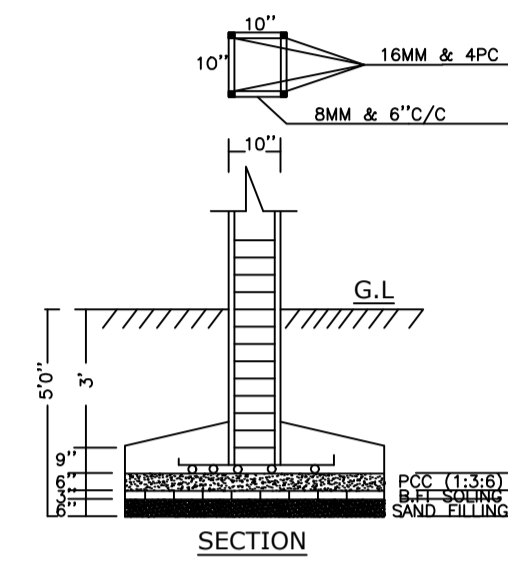

SECTION

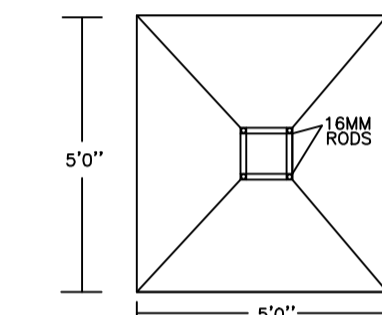

PLAN (SCALE 1"=4')

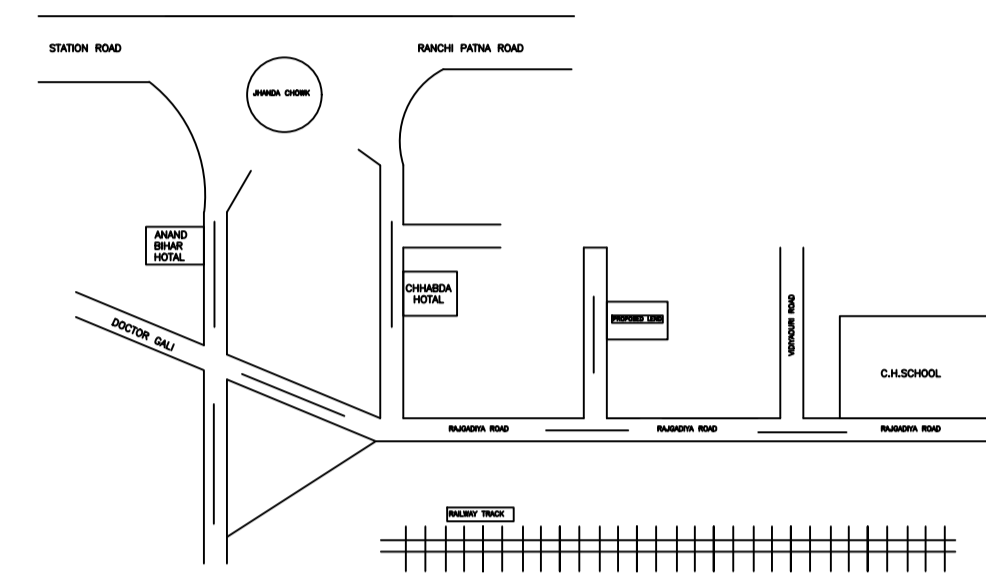

LOCATION PLAN (SCALE -1"32')

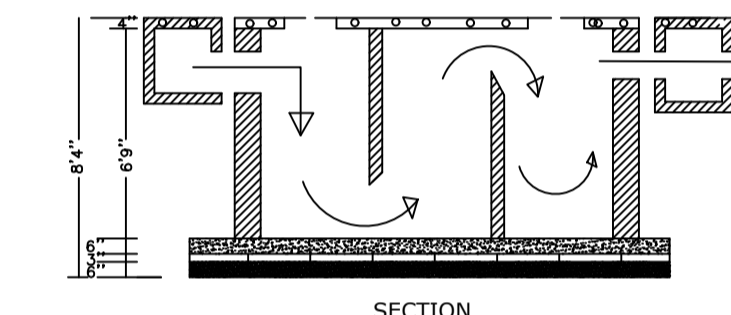

SECTION

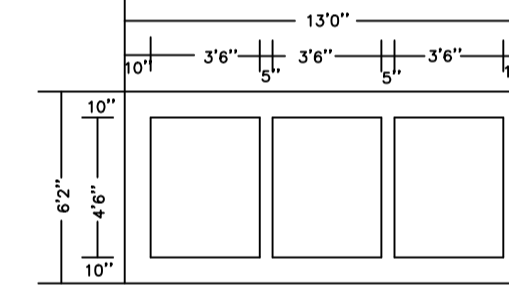

PLAN OF SEPTIC TANK

AREA STATEMENT		VERSION NO. : 1.0.46
JHUMRITILAIYA NAGAR PARISHAD		VERSION DATE: 22/06/2020
PROJECT DETAIL:		
Region: JHARKHAND URBAN LOCAL BODIES	Plot Use: Residential	
District: KODERMA	Plot SubUse: Bungalow/ Dwelling / Non Apartment	
Authority: JHUMRITILAIYA NAGAR PARISHAD	PlotNearbyReligiousStructure: NA	
Inward No: JNP/BI/0021/W/10/2020	PlotSubPlot No: 7459	
Application Type: General Proposal	North: Plot No. - VISHAL JAIN	
Project Type: Building Permission	South: Plot No. - VISHNU PRASAD BARNWAL	
Nature of Development: New	East: Plot No. - KASHMIRI KUMAR	
Location of Development Area: Old Area	West: Road Width - 3.6	
AREA DETAILS:		
AREA OF PLOT (Minimum)	(A)	SQ.MT. 74.88
NET AREA OF PLOT(Gross Plot Area - Deduction from Gross Plot area)	(A-Deductions)	74.88
Deduction for Balance Plot Area(from Gross Plot Area)		
Common Plot		7.25
Total		7.25
BALANCE AREA OF PLOT(Net Plot Area - Recreational/Amenity space)	(A-Deductions)	67.63
PLOT AREA FOR COVERAGE(Net Plot Area)	(A-Deductions)	74.88
Plot Area for FAR (Net Plot Area + RoadWidening Area)	(A-Deductions)	74.88
COVERAGE CHECK		
Permissible Coverage area (70.00 %)		52.42
Proposed Coverage Area (65.64 %)		49.15
Total Prop. Coverage Area (65.64 %)		49.15
Balance coverage area (4.37 %)		3.27
FAR CHECK		
Perm. FAR Area (1.50)		112.32
Total Perm. FAR area		112.32
Residential FAR		98.29
Proposed FAR Area		98.29
Total Proposed FAR Area		98.29
Consumed FAR (Factor)		1.31
Balance FAR Area		14.03
BUILT UP AREA CHECK		
Total Proposed BuiltUp Area		98.30
ARCHITECT (Regd) KIRAN KUMARI		
ENGINEER (Regd)		
SUPERVISOR (Regd)		
OWNER (Regd) MAMTA DEVI JAIN		
DEVELOPMENT AUTHORITY LOCAL BODY		

COLOR INDEX	
PLOT BOUNDARY	Black
ABUTTING ROAD	Red
PROPOSED CONSTRUCTION	Green
COMMON PLOT	Yellow
ROAD WIDENING AREA	Blue
EXISTING (To be retained)	Orange
EXISTING (To be demolished)	Grey

Buildingwise Floor FAR Details

Floor Name	Building Name A (RESIDENTIAL)		Total	
	Proposed Built Up Area (Sq.mt.)	Proposed FAR Area (Sq.mt.)	Total Proposed Built Up Area (Sq.mt.)	Total FAR Area (Sq.mt.)
Ground Floor	49.15	49.15	49.15	49.15
First Floor	49.15	49.15	49.15	49.15
Terrace Floor	0.00	0.00	0.00	0.00
Total :	98.30	98.30	98.30	98.30

Building USE/SUBUSE Details

Building Name	Building Use	Building SubUse	Building Structure
A (RESIDENTIAL)	Residential	Bungalow/ Dwelling / Non Apartment	Non-Highrise

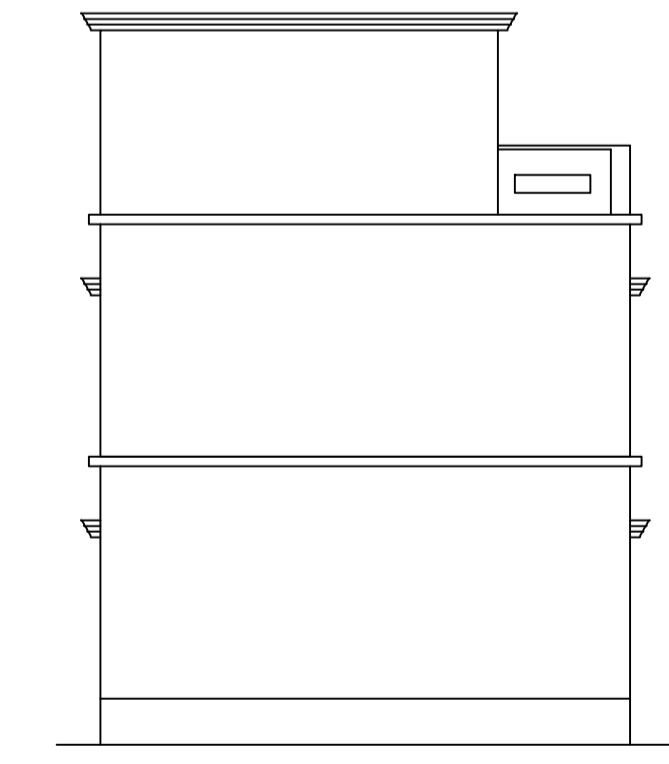

CROSS ELEVATION

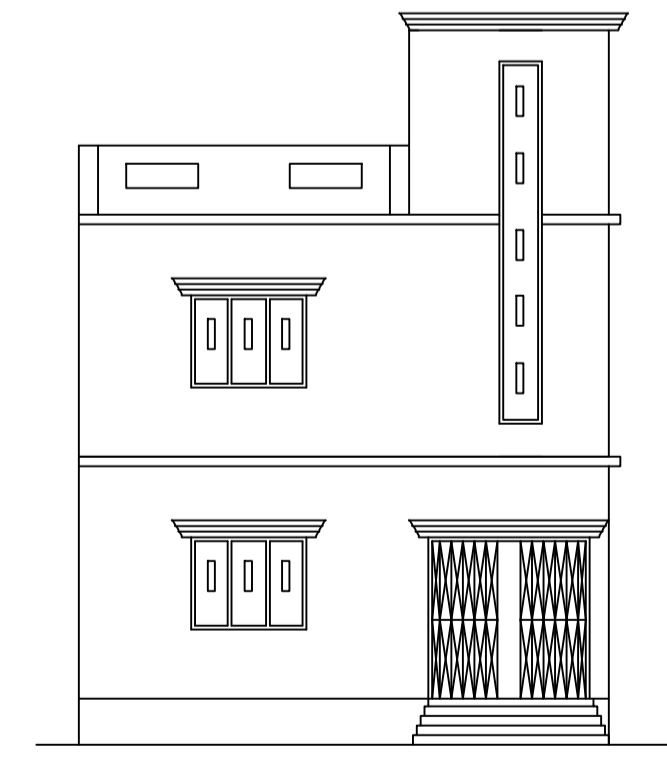

FRONT ELEVATION

LTP NAME AND SIGNATURE	STRUCTURAL ENG'S NAME AND SIGNATURE	BUILDER NAME AND SIGNATURE	DIGITAL SIGNATURE
KIRAN KUMARI JNP/ENG/001/2019			