

SITE PLAN

FAR & Tenement Details (Table 4c-1)

Building	No. of Same Bldg	Total Built Up Area (Sq.mt.)	Proposed FAR Area (Sq.mt.) Resi.	Total FAR Area (Sq.mt.)	Total Consumed Additional FAR Area (Sq.mt.)	Tnmt (No.)
A (RESIDENTIAL)	1	241.32	241.32	241.32	241.32	01
Grand Total :	1	241.32	241.32	241.32	241.32	01

Proposal Basic Information

Proposal File No.	JNP/BI/0016/W05/2020
Owner Name	SMT PRIYANKA KUMARI
Khata No	33
Plot No	1917
Village Name	Asana
Use	Residential
SubUse	Bungalow/ Dwelling / Non Apartment

AREA STATEMENT	VERSION NO.: 1.0.46
JHUMRITILAIYA NAGAR PARISHAD	VERSION DATE: 22/06/2020
PROJECT DETAIL:	
Region: JHARKHAND URBAN LOCAL BODIES	Plot Use: Residential
District: KODERMA	Plot SubUse: Bungalow/ Dwelling / Non Apartment
Authority: JHUMRITILAIYA NAGAR PARISHAD	PlotNearby/ReligiousStructure: NA
Inward No.: JNP/BI/0016/W05/2020	Plot/SubPlot No: 1917
Application Type: General Proposal	North: Road Width - 3.65
Project Type: Building Permission	South: Plot No. - LAND OF SRI BALESHWAR SARMA AND OTHERS
Nature of Development: New	East: Plot No. - NIJ VENDOR
Location of Development Area: Old Area	West: Plot No. - NIJ VENDOR
AREA DETAILS:	
AREA OF PLOT (Minimum)	(A) 161.62
NET AREA OF PLOT(Gross Plot Area - Deduction from Gross Plot area)	(A-Deductions) 161.62
Deduction for Balance Plot Area(from Gross Plot Area)	
Common Plot	20.80
Total	20.80
BALANCE AREA OF PLOT(Net Plot Area - Recreational/Amenity space)	(A-Deductions) 140.82
PLOT AREA FOR COVERAGE(Net Plot Area)	(A-Deductions) 161.62
Plot Area for FAR (Net Plot Area + Road Widening Area)	(A-Deductions) 161.62
COVERAGE CHECK	
Permissible Coverage area (70.00 %)	113.13
Proposed Coverage Area (49.77 %)	80.44
Total Prop. Coverage Area (49.77 %)	80.44
Balance coverage area (20.23 %)	32.69
FAR CHECK	
Perm. FAR Area (1.50)	242.43
Total Perm. FAR area	242.43
Residential FAR	241.33
Proposed FAR Area	241.33
Total Proposed FAR Area	241.33
Consumed FAR (Factor)	1.49
Balance FAR Area	1.10
BUILT UP AREA CHECK	
Total Proposed BuiltUp Area	241.32
ARCHITECT (Regd)	KIRAN KUMARI
ENGINEER (Regd)	
SUPERVISOR (Regd)	
OWNER (Regd)	SMT PRIYANKA KUMARI
DEVELOPMENT AUTHORITY	LOCAL BODY

COLOR INDEX	
PLOT BOUNDARY	Black
ABUTTING ROAD	Green
PROPOSED CONSTRUCTION	Red
COMMON PLOT	White
ROAD WIDENING AREA	Yellow
EXISTING (To be retained)	Blue
EXISTING (To be demolished)	Orange

Buildingwise Floor FAR Details

Floor Name	Building Name A (RESIDENTIAL)		Total	
	Proposed Built Up Area (Sq.mt.)	Proposed FAR Area (Sq.mt.)	Total Proposed Built Up Area (Sq.mt.)	Total FAR Area (Sq.mt.)
Ground Floor	80.44	80.44	80.44	80.44
First Floor	80.44	80.44	80.44	80.44
Second Floor	80.44	80.44	80.44	80.44
Terrace Floor	0.00	0.00	0.00	0.00
Total :	241.32	241.32	241.32	241.32

Building USE/SUBUSE Details

Building Name	Building Use	Building SubUse	Building Structure
A (RESIDENTIAL)	Residential	Bungalow/ Dwelling / Non Apartment	Non-Highrise

LTP NAME AND SIGNATURE	STRUCTURAL ENG'S NAME AND SIGNATURE	BUILDER NAME AND SIGNATURE	DIGITAL SIGNATURE
KIRAN KUMARI JNP/ENG/0001/2019			

Proposal Basic Information

Proposal File No.	JNP/IBP/0016/W05/2020
Owner Name	SMT PRIYANKA KUMARI
Khata No	33
Plot No	1917
Village Name	Asana
Use	Residential
SubUse	Bungalow/ Dwelling / Non Apartment

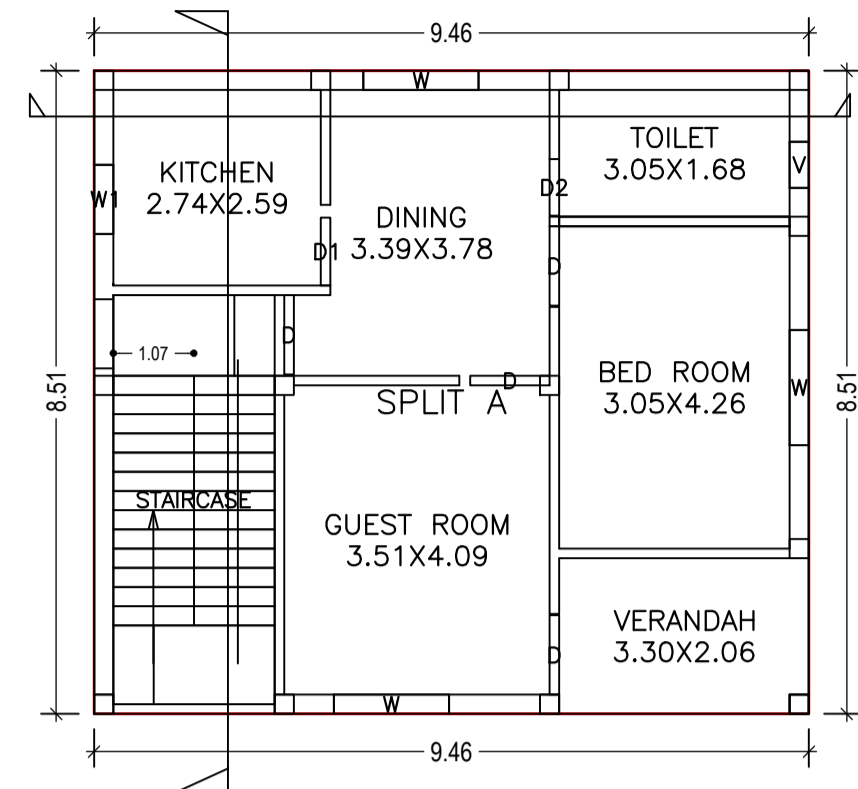

GROUND FLOOR PLAN
(Proposed)
(SCALE 1:100)

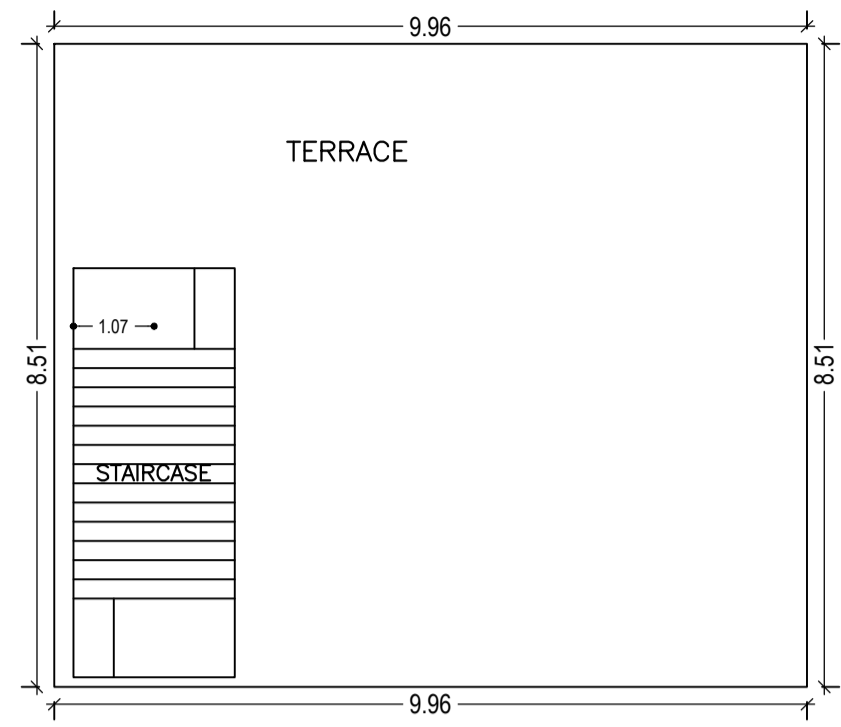

TERRACE FLOOR PLAN
(SCALE 1:100)

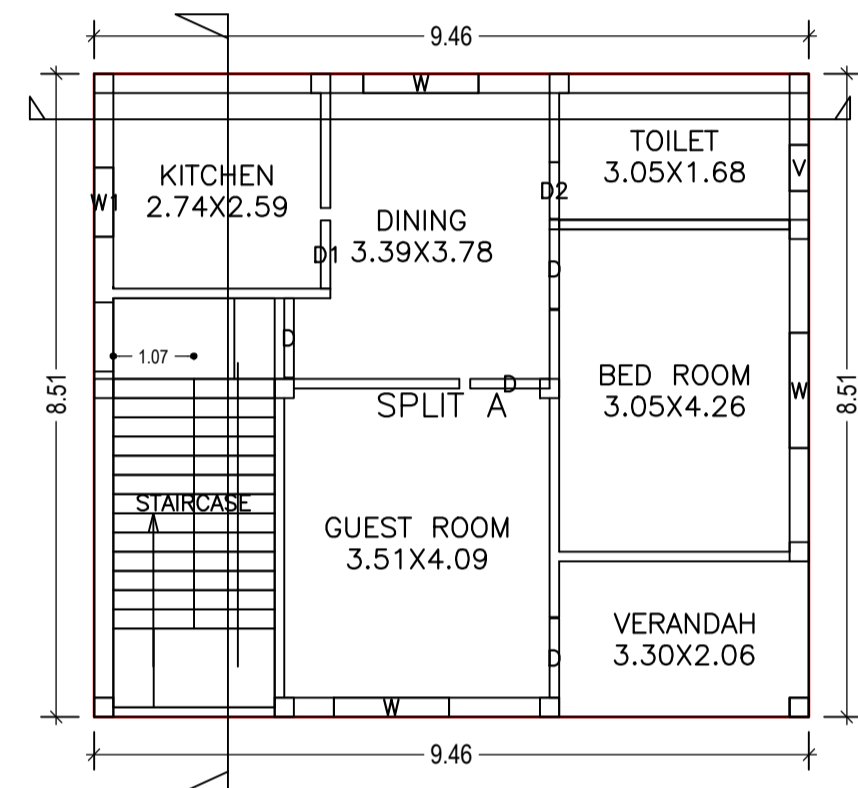

FIRST FLOOR PLAN
(Proposed)
(SCALE 1:100)

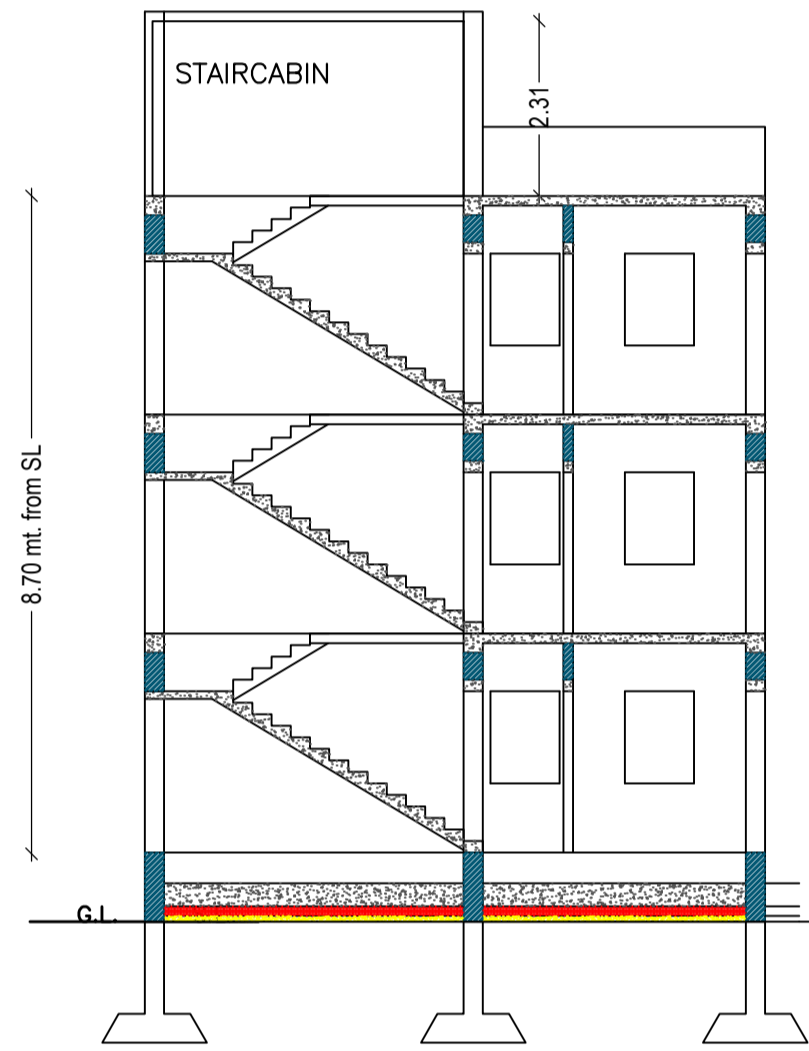

CROSS SECTION (A)

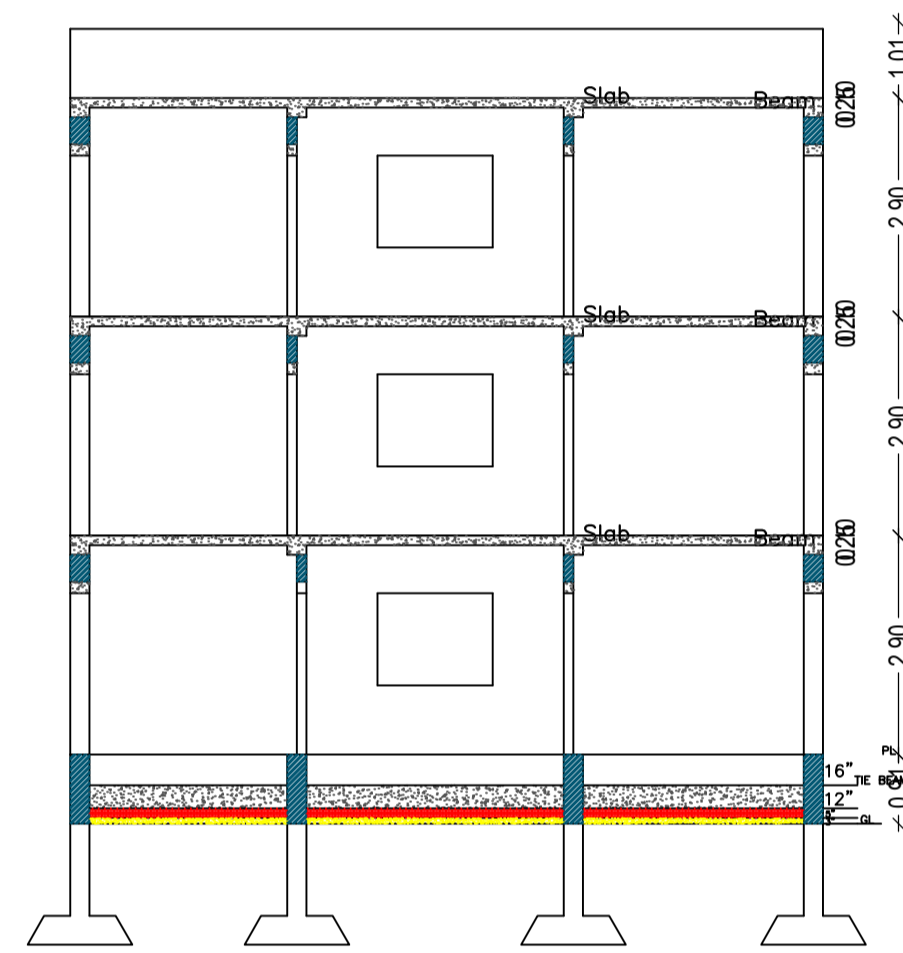

CROSS SECTION (B)

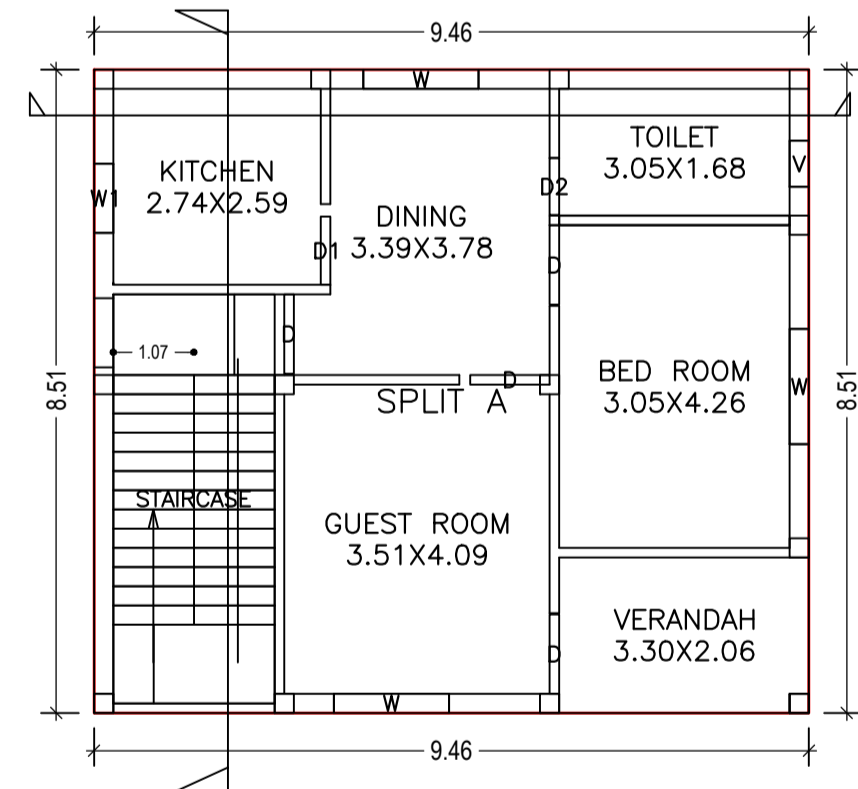

SECOND FLOOR PLAN
(Proposed)
(SCALE 1:100)

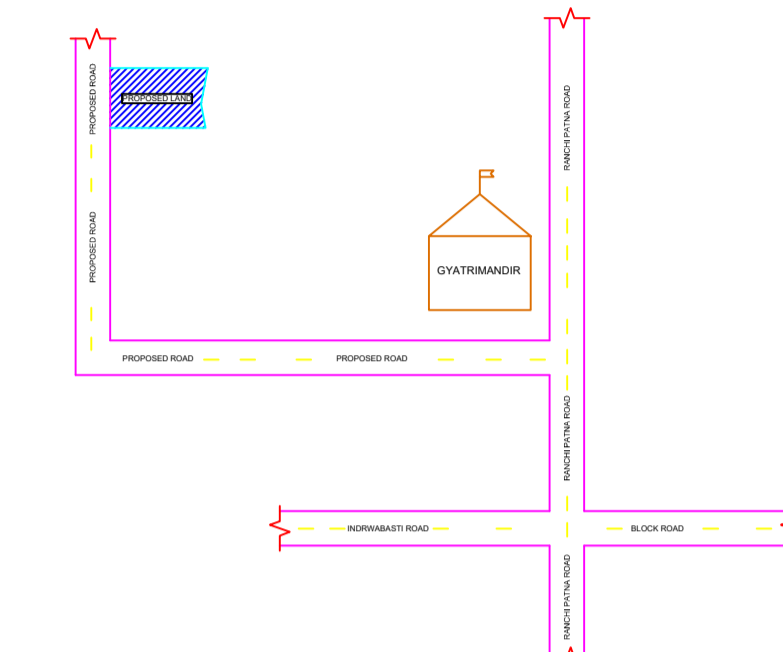

LOCATION PLAN (SCALE -1''16')

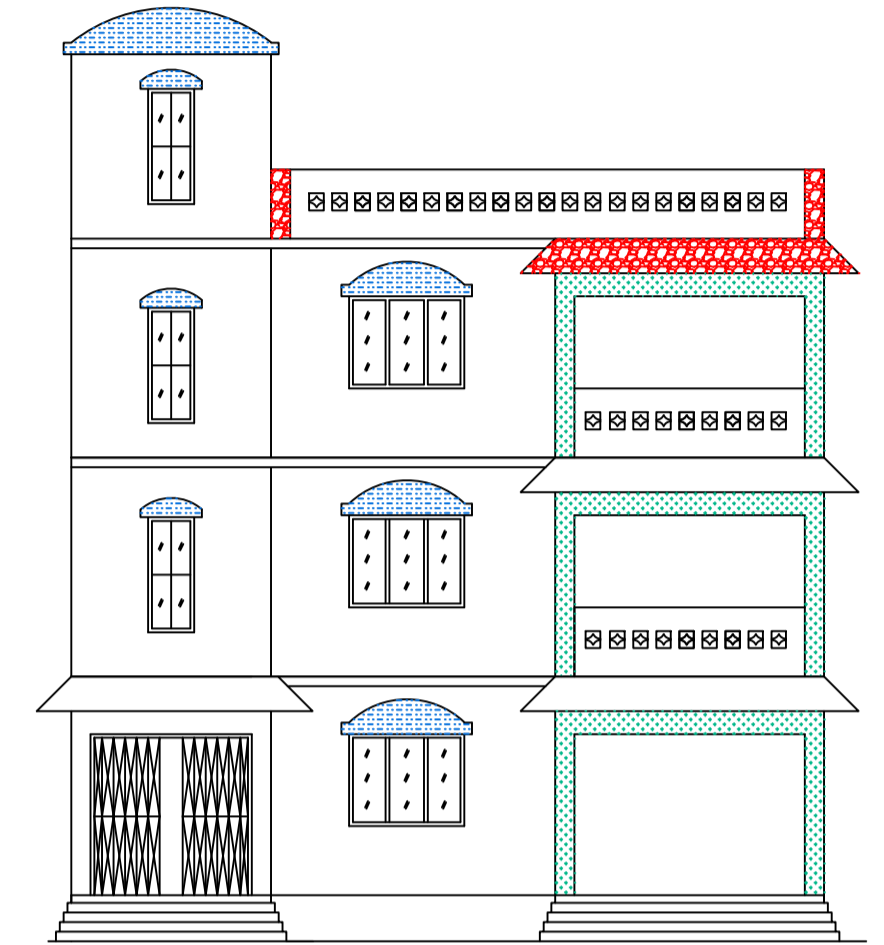

FRONT ELEVATION

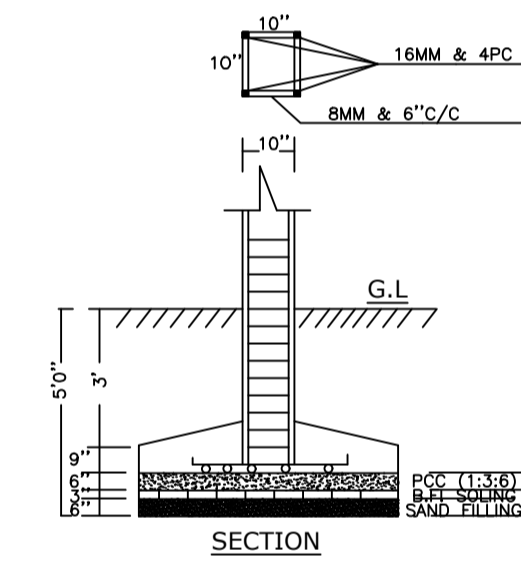

SECTION

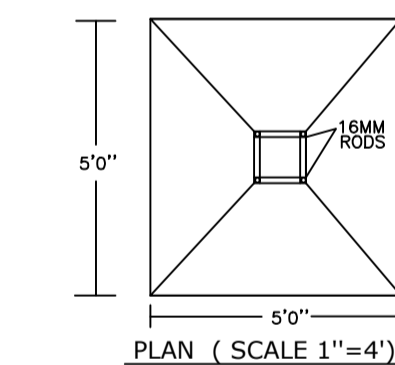

PLAN (SCALE 1''=4')

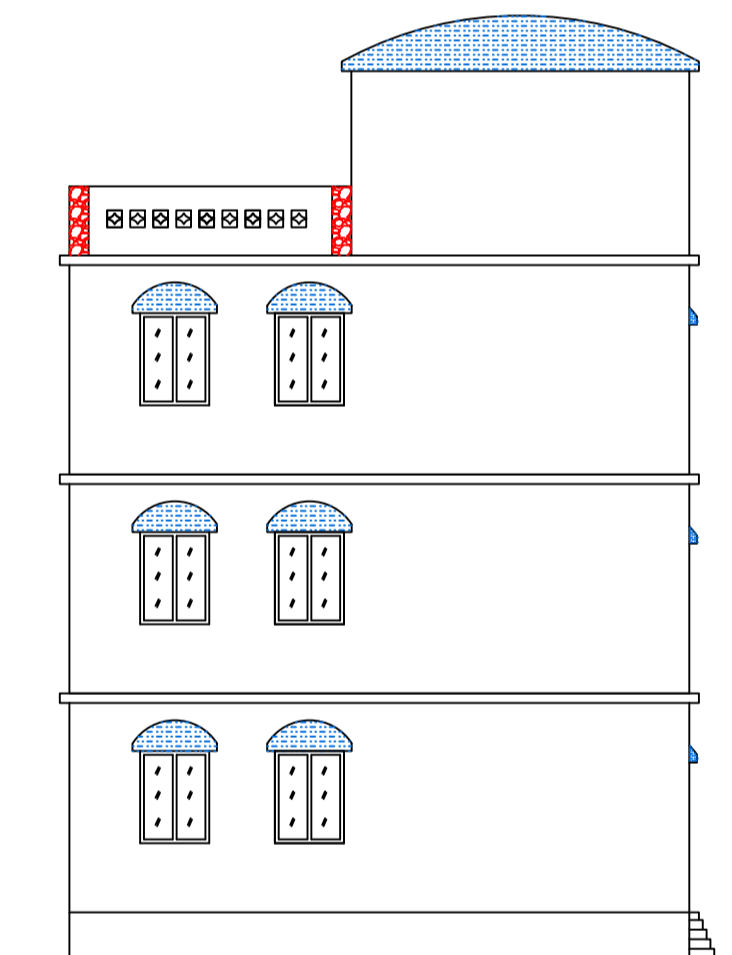

CROSS ELEVATION

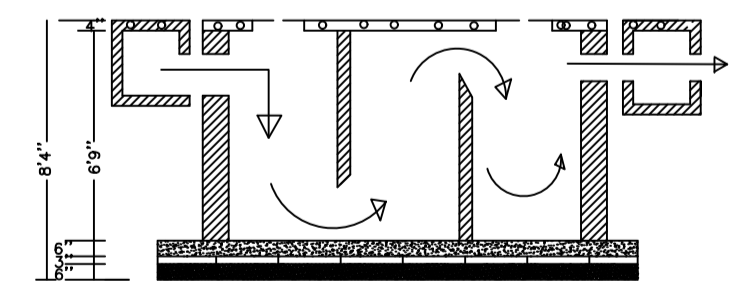

SECTION

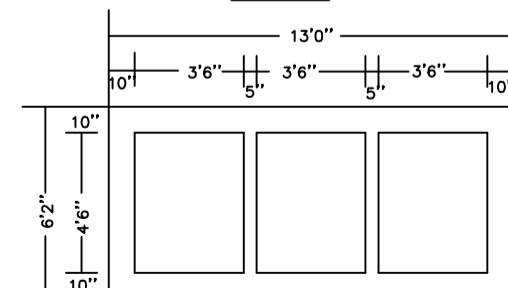

PLAN OF SEPTIC TANK

Building :A (RESIDENTIAL)

Floor Name	Total Built Up Area (Sq.mt.)	Proposed FAR Area (Sq.mt.) Resi.	Total FAR Area (Sq.mt.)	Total Consumed Additional FAR Area (Sq.mt.)	Tnmt (No.)
Ground Floor	80.44	80.44	80.44	80.44	01
First Floor	80.44	80.44	80.44	80.44	00
Second Floor	80.44	80.44	80.44	80.44	00
Terrace Floor	0.00	0.00	0.00	0.00	00
Total:	241.32	241.32	241.32	241.32	01
Total Number of Same Buildings	1				
Total:	241.32	241.32	241.32	241.32	01

SCHEDULE OF DOOR:

BUILDING NAME	NAME	LENGTH	HEIGHT	NOS
A (RESIDENTIAL)	D2	0.75	2.10	03
A (RESIDENTIAL)	D1	0.90	2.10	03
A (RESIDENTIAL)	D	1.05	2.10	12

SCHEDULE OF WINDOW/VENTILATION:

BUILDING NAME	NAME	LENGTH	HEIGHT	NOS
A (RESIDENTIAL)	V	0.61	0.90	03
A (RESIDENTIAL)	W1	0.91	1.20	03
A (RESIDENTIAL)	W	1.52	1.20	09

UnitBUA Table for Building :A (RESIDENTIAL)

FLOOR	Name	UnitBUA Type	UnitBUA Area	Carpet Area	No. of Rooms	No. of Tenement
GROUND FLOOR PLAN	SPLIT A	FLAT	181.93	180.76	6	1
FIRST FLOOR PLAN	SPLIT A	FLAT	0.00	0.00	6	0
SECOND FLOOR PLAN	SPLIT A	FLAT	0.00	0.00	6	0
Total:	-	-	181.93	180.76	18	1

LTP NAME AND SIGNATURE KIRAN KUMARI JNP/ENG/0001/2019	STRUCTURAL ENG'S NAME AND SIGNATURE	BUILDER NAME AND SIGNATURE	DIGITAL SIGNATURE
---	-------------------------------------	----------------------------	-------------------