

Project Title :  
 PROPOSED BUILDING PLAN FOR SRI. MILAN PRASAD .S/O - LATE. SATYANARAYAN PRASAD . MAUZA-TELAIYA .  
 WARD NO- 12. P.S- TELAIYA. P.S NO- 244. KHATA NO- 890,1151. PLOT NO- 7347,7345. DIST- KODERMA (JHARKHAND).

PROPOSED BUILDING PLAN FOR SRI. MILAN PRASAD .S/O - LATE. SATYANARAYAN PRASAD . MAUZA-TELAIYA .  
 WARD NO- 12. P.S- TELAIYA. P.S NO- 244. KHATA NO- 890,1151. PLOT NO- 7347,7345. DIST- KODERMA (JHARKHAND).

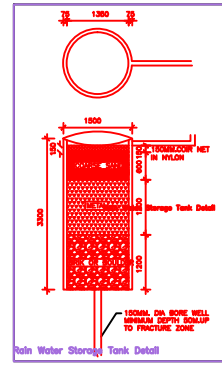
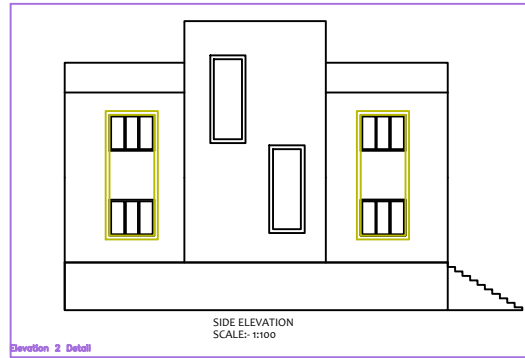
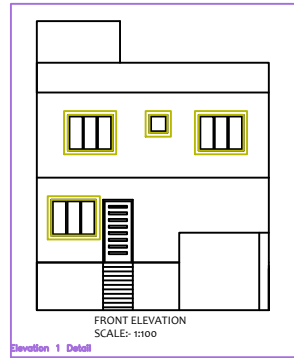

NORTH - 1 M WIDE GALI  
 SOUTH - BHATU HAJJAM & OTHERS  
 EAST - GALI & RITU  
 WEST - GURUDWARA ROAD

W.H.T - WATER HARVESTING TANK.  
 S.T - SEPTIC TANK.

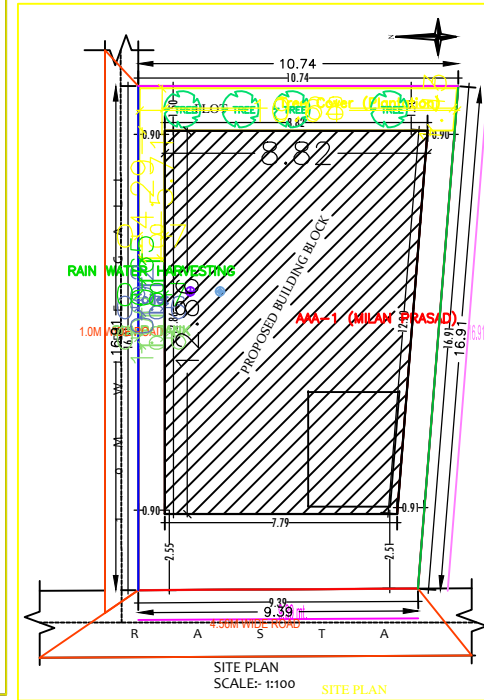
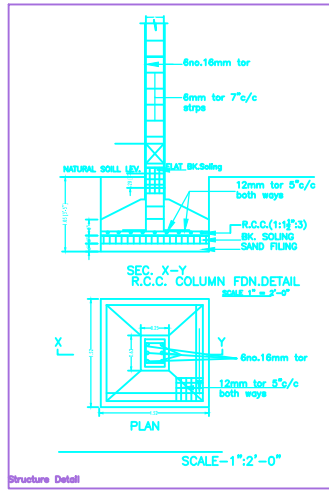
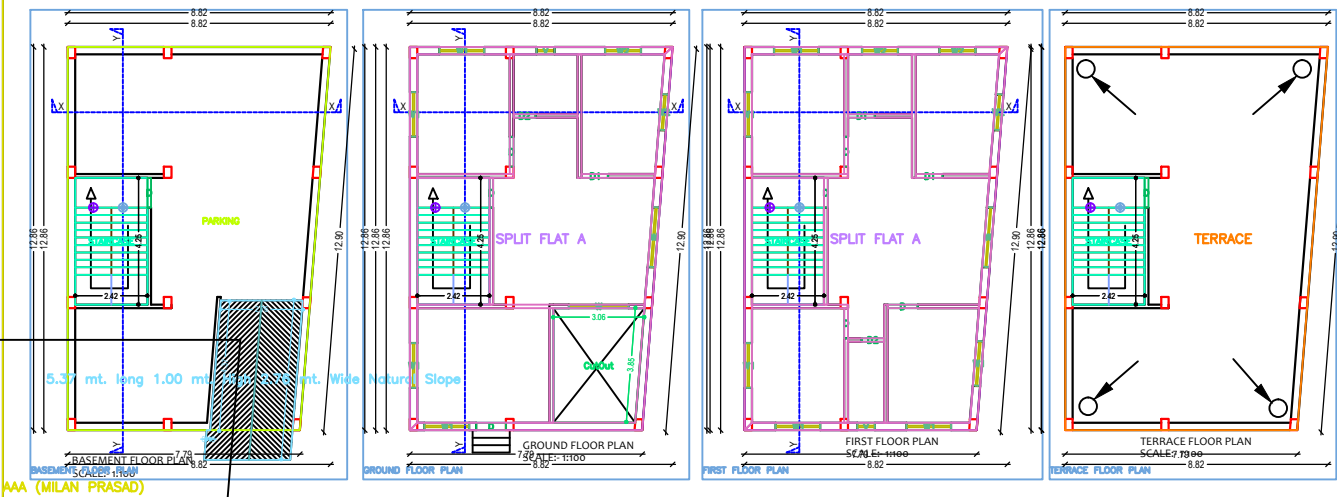
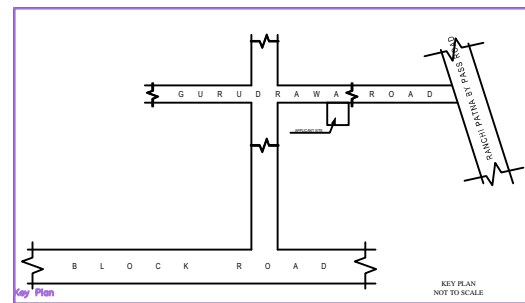
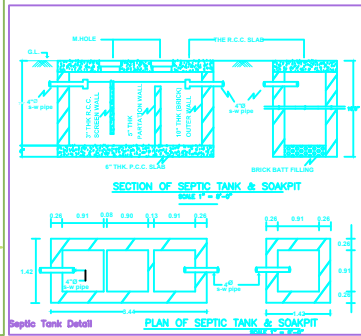
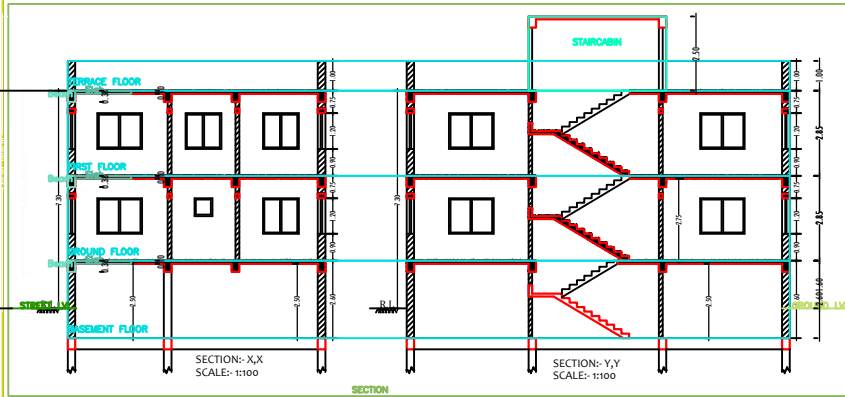

AREA STATEMENT: JHUMRILAYA NAGAR PARISHAD		VERSION NO. 1.0.22
PROJECT DETAIL:		
Plot No.:	-	Plot Use: Residential
Region:	JHARKHAND URBAN LOCAL BODIES	Plot Sub-Use: Single/Dwelling / Non Apartment
District:	KODERMA	Land Use Zone: NA
Application Type:	General Proposal	Abutting Road Width: -
Project Type:	Building Permission	Plot No.:
Name of Development:	-	Revenue Survey No/Survey No.:
Location:	OG Area	Theme No.:
Sub Location:	NA	Holding No.:
Village/Mauza Name:	-	Khata No.:
Ward No.:	-	North:
Road/Street:	-	South:
		East:
		West:
AREA DETAILS:		
AREA OF PLOT (Minimum)	(A)	SQ.MT.
Total Plot Area (Gross Plot Area)	-	169.97
- Deduction from Gross Plot Area	(A-Deductions)	169.97
Deductions for Balance Plot Area (from Gross Plot Area)	-	-
COP Area	-	18.70
Total	-	18.70
Balance Plot Area (Net Plot Area - Recreational/Amenity space)	(A-Deductions)	151.26
Plot Area for Coverage (Net Plot Area)	(A-Deductions)	169.97
Plot Area for FSI (Net Plot Area - Road/Widening Area)	(A-Deductions)	169.97
Accession Use Area	-	0.75
COVERAGE CHECK		
Proposed Coverage Area (56.26 %)	-	95.62
Total Coverage Area (56.26 %)	-	95.62
FAR CHECK		
Proposed Area of FAR	-	212.68
Total Area of FAR	-	212.68
BUILT UP AREA CHECK		
Total Proposed Built-Up Area	-	309.16
ARCHT ENGG / SUPERVISOR (Regd)	-	OWNER
	-	LOCAL BODY

COLOR INDEX	
PLOT BOUNDARY	Black
ABUTTING ROAD	Red
PROPOSED WORK (COVERAGE AREA)	Green
EXISTING (To be retained)	Yellow
EXISTING (To be demolished)	Blue

PARKING CALCULATION:		
Parking Type	Prop No.	Prop Area
Other Parking	1	96.48
Total Area	1	96.48

MARGIN DETAIL:					
Building / Wing Name	Road Name	Front Margin	Rear Margin	Side1 Margin	Side2 Margin
AAA-1 (MILAN PRASAD)	4.56M WIDE ROAD	2.51	1.50	0.90	0.90

BASEMENT MARGIN DETAIL:					
Building / Wing Name	Road Name	Front Margin	Rear Margin	Side1 Margin	Side2 Margin
AAA-1 (MILAN PRASAD)	4.56M WIDE ROAD	2.51	1.50	0.90	0.90

FAR & Tenement Details (Table 4c-1)									
Building	No. of Same Bldg	Gross Built Up Area (Sq.mt.)	Deductions From Gross BUA (Area in Sq.mt.)	Total Built Up Area (Sq.mt.)	Deductions (Area in Sq.mt.)	Proposed FAR Area (Sq.mt.)	Add Area In FAR (Sq.mt.)	Total FAR Area (Sq.mt.)	Tenmt (No.)
AAA (MILAN PRASAD)	1	320.31	11.15	309.16	96.48	202.39	10.29	212.68	01
Grand Total	1	320.31	11.15	309.16	96.48	202.39	10.29	212.68	01

Building 'AAA (MILAN PRASAD)									
Floor Name	Gross Builtup Area (Sq.mt.)	Deductions From Gross BUA/Area in (Sq.mt.)	Total Built Up Area (Sq.mt.)	Deductions (Area in (Sq.mt.)	Proposed FAR Area (Sq.mt.)	Add Area In FAR (Sq.mt.)	Total FAR Area (Sq.mt.)	Tenmt (No.)	
Basement Floor	106.77	0.00	106.77	96.48	0.00	10.29	10.29	00	
Ground Floor	106.77	11.15	95.62	0.00	95.62	0.00	95.62	01	
First Floor	106.77	0.00	106.77	0.00	106.77	0.00	106.77	00	
Terrace Floor	0.00	0.00	0.00	0.00	0.00	0.00	0.00	00	
Total	320.31	11.15	309.16	96.48	202.39	10.29	212.68	01	
Total Number of Same Buildings	1	-	-	-	-	-	-	-	
Total	320.31	11.15	309.16	96.48	202.39	10.29	212.68	01	

SCHEDULE OF JOINERY:				
BUILDING NAME	NAME	LENGTH	HEIGHT	NOs
AAA (MILAN PRASAD)	D2	0.75	2.13	02
AAA (MILAN PRASAD)	D1	0.90	2.13	03
AAA (MILAN PRASAD)	D	1.00	2.13	09
TOTAL	-	-	-	14

SCHEDULE OF JOINERY:				
BUILDING NAME	NAME	LENGTH	HEIGHT	NOs
AAA (MILAN PRASAD)	V	0.60	1.00	02
AAA (MILAN PRASAD)	W2	1.20	1.20	06
AAA (MILAN PRASAD)	W1	1.50	1.20	10
AAA (MILAN PRASAD)	W	2.00	1.20	03
TOTAL	-	-	-	20

Unit/BUA Table for Building 'AAA (MILAN PRASAD)						
FLOOR	Name	Unit/BUA Type	Unit/BUA Area	Carpet Area	No. of Rooms	No. of Tenement
GROUND FLOOR PLAN	SPLIT FLAT A	FLAT	161.13	152.73	5	1
TOTAL	-	-	161.13	152.73	13	1