

FAR & Tenement Details (Table 4c-1)

Building	No. of Same Bldg	Total Built Up Area (Sq.mt.)	Proposed FAR Area (Sq.mt.) Resi.	Total FAR Area (Sq.mt.)	Total Consumed Additional FAR Area (Sq.mt.)	Tnmt (No.)
A (LALITA DEVI HOUSE PLAN)	1	86.90	86.90	86.90	86.90	01
Grand Total :	1	86.90	86.90	86.90	86.90	01

Proposal Basic Information

Proposal File No.	JNP/BP/0069/W07/2020
Owner Name	SMT. LALITA DEVI
Khata No	18
Plot No	319
Village Name	Jhalpo
Use	Residential
SubUse	Bungalow/ Dwelling / Non Apartment

AREA STATEMENT

JHUMRITLAIYA NAGAR PARISHAD

PROJECT DETAIL:

Region: JHARKHAND URBAN LOCAL BODIES Plot Use: Residential

District: KODERMA Plot SubUse: Bungalow/ Dwelling / Non Apartment

Authority: JHUMRITLAIYA NAGAR PARISHAD PlotNearby/ReligiousStructure: NA

Inward No: JNP/BP/0069/W07/2020 PlotSubPlot No: 319

Application Type: General Proposal North: Plot No. - LAND OF VENDORS (P.N. - 319(P)

Project Type: Building Permission South: Plot No. - LAND OF HANIF MIYA & OTHERS

Nature of Development: New East: Road Width - 3.65 Mtr. WIDE ROAD

Location of Development Area: Old Area West: Plot No. - LAND OF MEHANDI HUSSAIN & OTHERS

AREA DETAILS:		SQ.MT.
AREA OF PLOT (Minimum)	(A)	161.00
Deduction for NetPlot Area		
Road Widening Area		8.37
Total		8.37
NET AREA OF PLOT(Gross Plot Area - Deduction from Gross Plot area)	(A-Deductions)	152.63
Deduction for Balance Plot Area(from Gross Plot Area)		
Road Widening Area		8.37
Common Plot		21.32
Total		29.69
BALANCE AREA OF PLOT(Net Plot Area - Recreational/Amenity space)	(A-Deductions)	131.31
PLOT AREA FOR COVERAGE(Net Plot Area)	(A-Deductions)	152.63
Plot Area for FAR (Net Plot Area + RoadWidening Area)	(A-Deductions)	152.63
COVERAGE CHECK		
Permissible Coverage area (70.00 %)		106.84
Proposed Coverage Area (56.94 %)		86.90
Total Prop. Coverage Area (56.94 %)		86.90
Balance coverage area (13.06 %)		19.94
FAR CHECK		
Perm. FAR Area (1.50)		228.95
Total Perm. FAR Area		228.95
Residential FAR		86.90
Proposed FAR Area		86.90
Total Proposed FAR Area		86.90
Consumed FAR (Factor)		0.57
Balance FAR Area		142.05
BUILT UP AREA CHECK		
Total Proposed BuiltUp Area		86.90
ARCHITECT (Regd)	UPENDRA	
ENGINEER (Regd)		
SUPERVISOR (Regd)		
OWNER (Regd)	SMT. LALITA DEVI	
DEVELOPMENT AUTHORITY	LOCAL BODY	

COLOR INDEX

PLOT BOUNDARY	Black
ABUTTING ROAD	Red
PROPOSED CONSTRUCTION	Green
COMMON PLOT	Yellow
ROAD WIDENING AREA	Blue
EXISTING (To be retained)	Light Blue
EXISTING (To be demolished)	Dark Blue

SMT. LALITA DEVI SITE PLAN

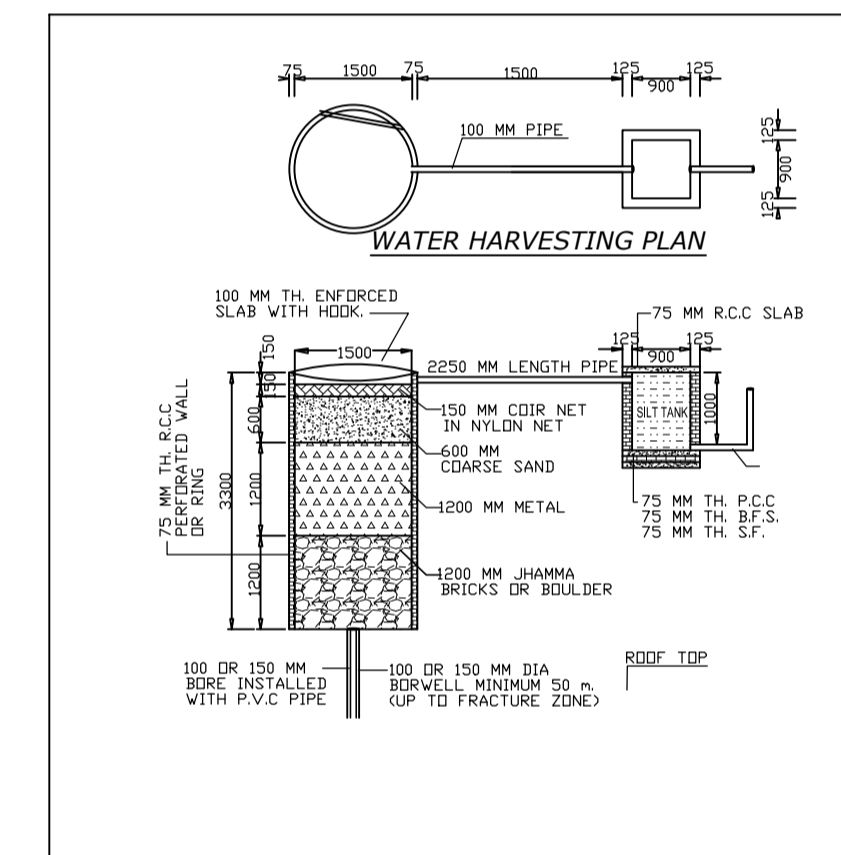
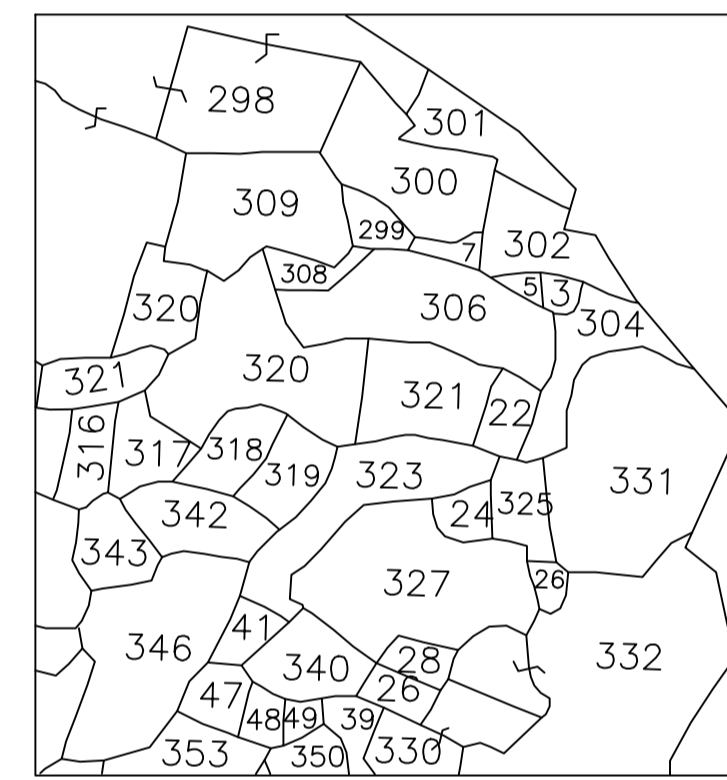
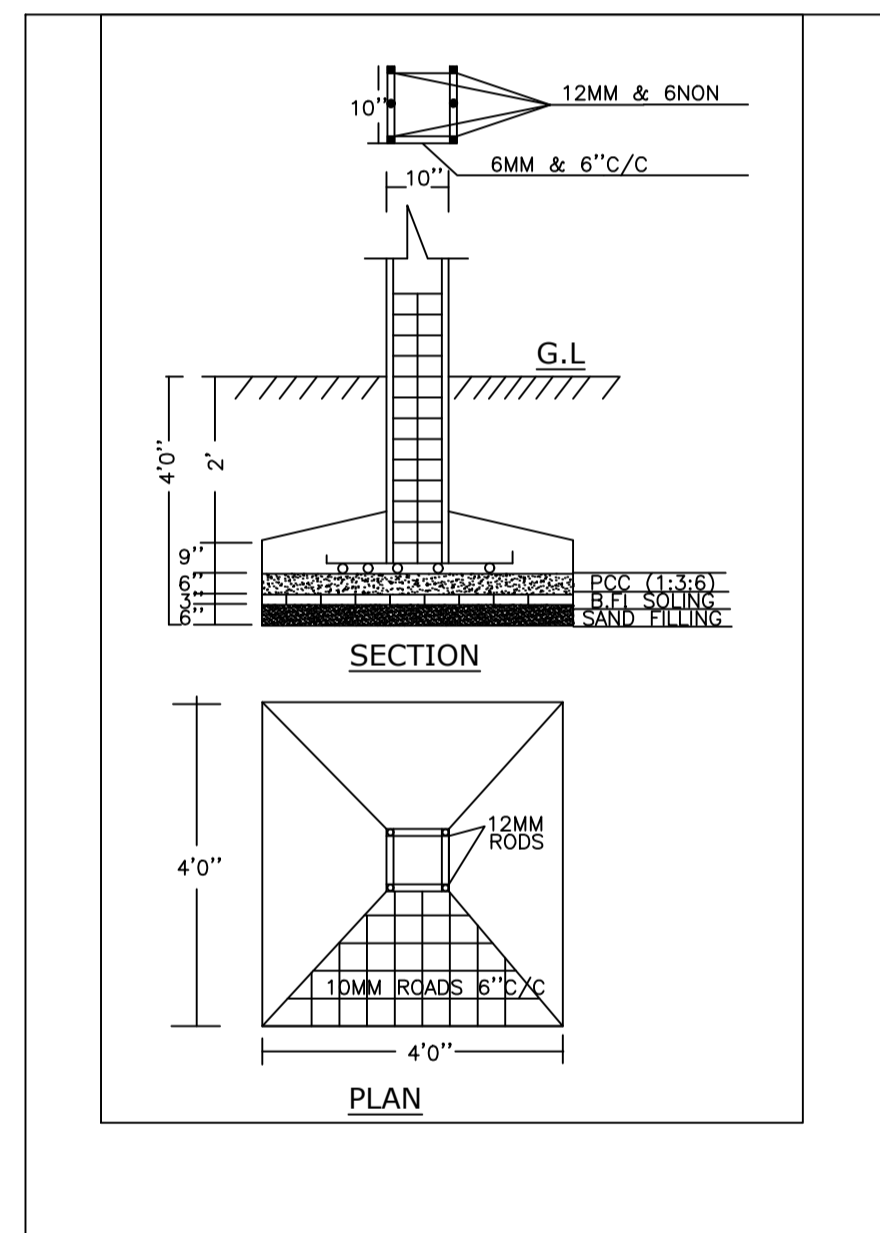
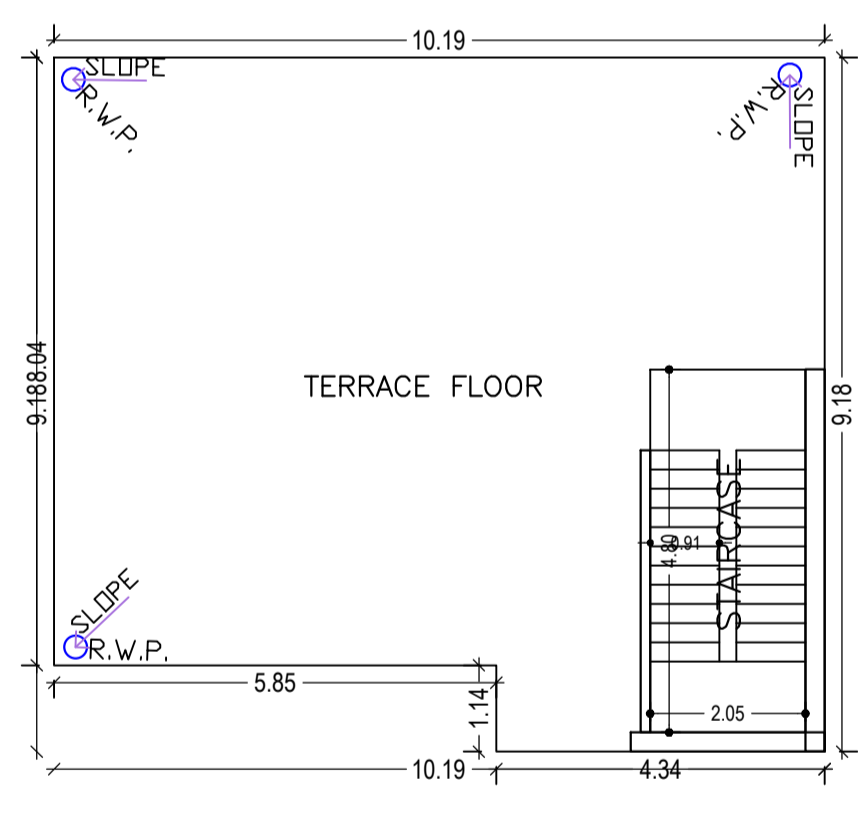
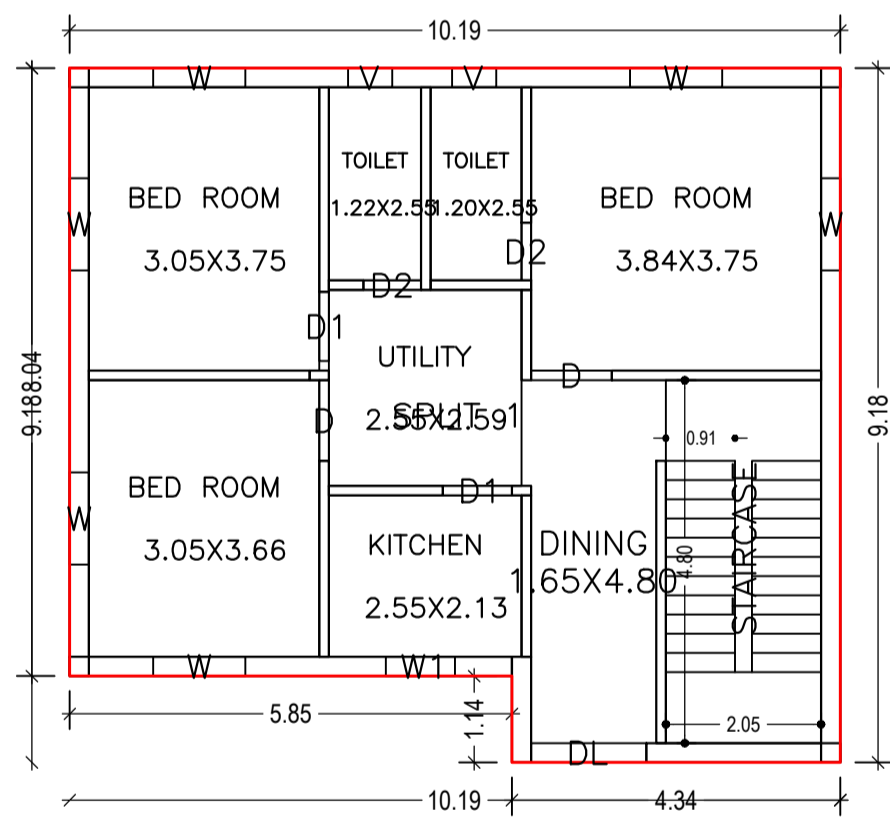

GROUND FLOOR PLAN (Proposed) (SCALE 1:100)

TERRACE FLOOR PLAN (SCALE 1:100)

SCHEDULE OF DOOR:

BUILDING NAME	NAME	LENGTH	HEIGHT	NOS
A (LALITA DEVI HOUSE PLAN)	D2	0.76	2.10	02
A (LALITA DEVI HOUSE PLAN)	D1	0.91	2.10	02
A (LALITA DEVI HOUSE PLAN)	D	1.07	2.10	02

SCHEDULE OF WINDOW/VENTILATION:

BUILDING NAME	NAME	LENGTH	HEIGHT	NOS
A (LALITA DEVI HOUSE PLAN)	V	0.59	1.20	02
A (LALITA DEVI HOUSE PLAN)	W1	0.91	1.20	01
A (LALITA DEVI HOUSE PLAN)	W	1.22	1.20	06

Building :A (LALITA DEVI HOUSE PLAN)

Floor Name	Total Built Up Area (Sq.mt.)	Proposed FAR Area (Sq.mt.) Resi.	Total FAR Area (Sq.mt.)	Total Consumed Additional FAR Area (Sq.mt.)	Tnmt (No.)
Ground Floor	86.90	86.90	86.90	86.90	01
Terrace Floor	0.00	0.00	0.00	0.00	00
Total :	86.90	86.90	86.90	86.90	01
Total Number of Same Buildings	1				
Total :	86.90	86.90	86.90	86.90	01

UnitBUA Table for Building :A (LALITA DEVI HOUSE PLAN)

FLOOR	Name	UnitBUA Type	UnitBUA Area	Carpet Area	No. of Rooms	No. of Tenement
GROUND FLOOR PLAN	SPLIT 1	FLAT	86.90	74.11	7	1
Total:	-	-	86.90	74.11	7	1

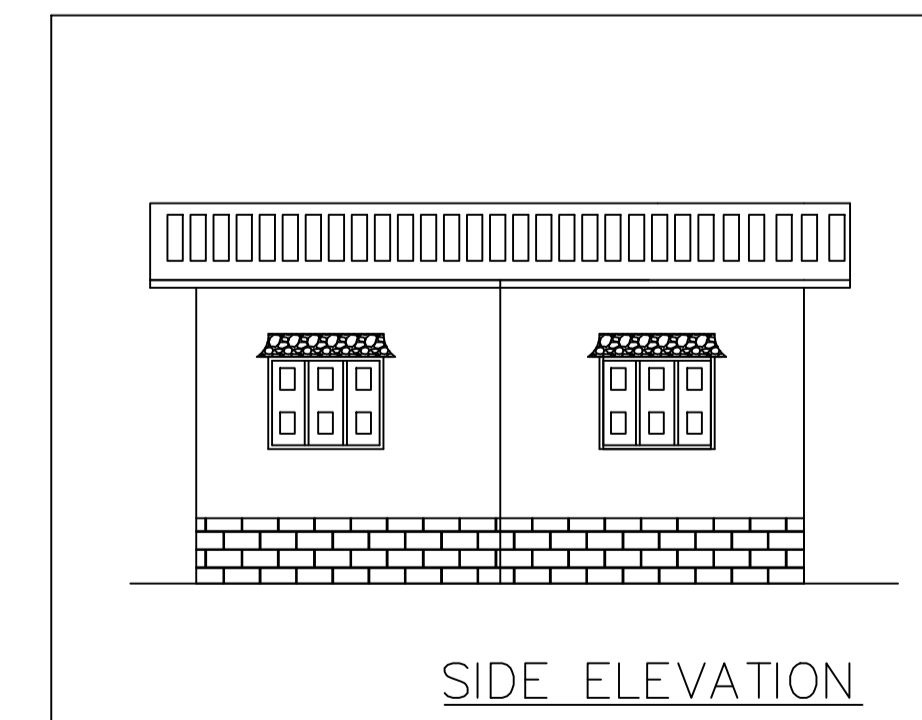

Buildingwise Floor FAR Details

Floor Name	Building Name		Total	
	Proposed Built Up Area (Sq.mt.)	Proposed FAR Area (Sq.mt.)	Total Proposed Built Up Area (Sq.mt.)	Total FAR Area (Sq.mt.)
Ground Floor	86.90	86.90	86.90	86.90
Terrace Floor	0.00	0.00	0.00	0.00
Total :	86.90	86.90	86.90	86.90

Building USE/SUBUSE Details

Building Name	Building Use	Building SubUse	Building Structure
A (LALITA DEVI HOUSE PLAN)	Residential	Bungalow/ Dwelling / Non Apartment	Non-Highrise

LTP NAME AND SIGNATURE	STRUCTURAL ENG'S NAME AND SIGNATURE	BUILDER NAME AND SIGNATURE	DIGITAL SIGNATURE
UPENDRA JNP/ENG/0012/2017			