

TERRACE FLOOR PLAN (SCALE 1:100)

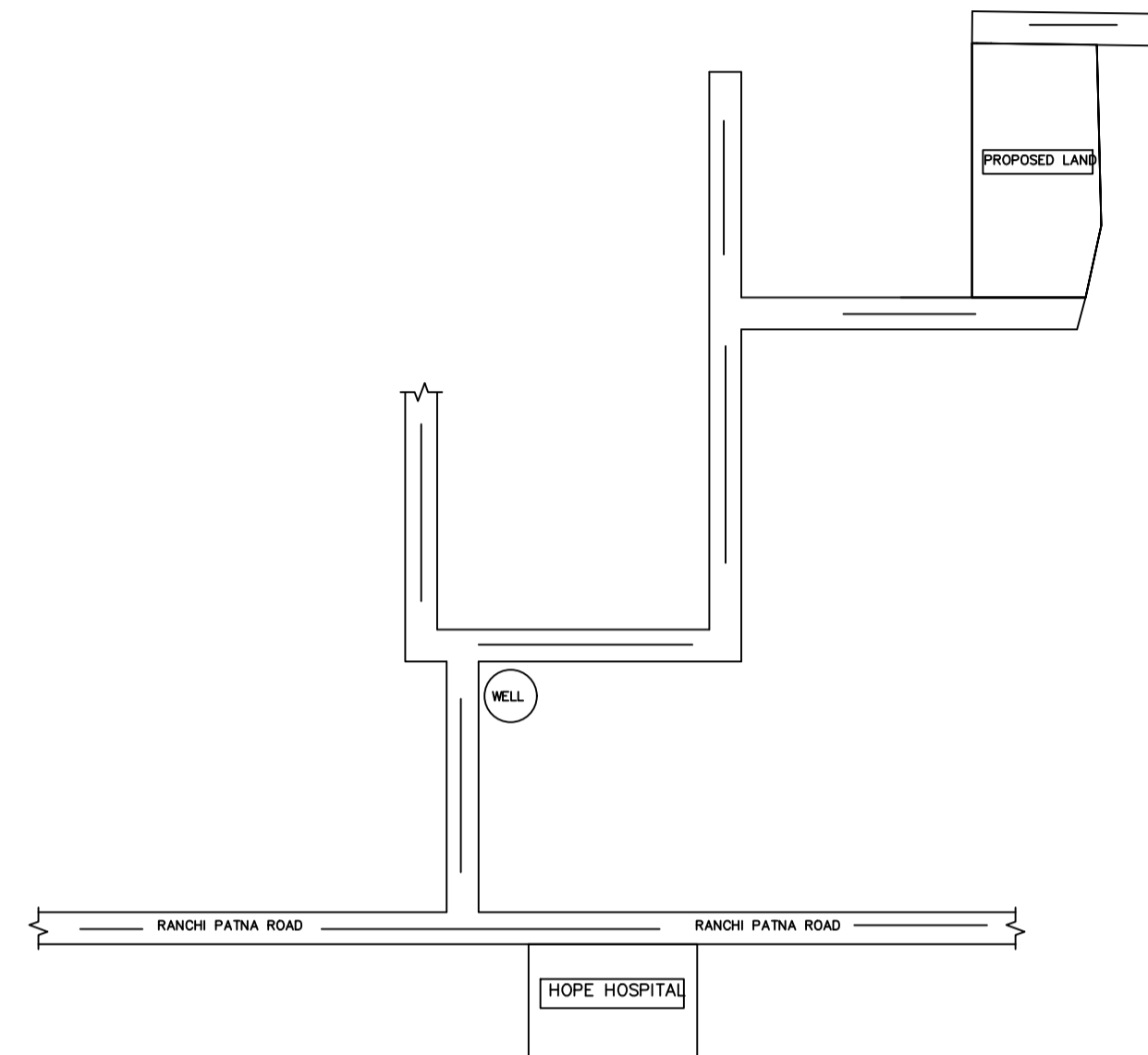

LOCATION PLAN (SCALE -1''16'')

FAR & Tenement Details (Table 4c-1)

Building	No. of Same Bldg	Total Built Up Area (Sq.mt.)	Deductions (Area in Sq.mt.)	Proposed FAR Area (Sq.mt.)	Total FAR Area (Sq.mt.)	Total Consumed Additional FAR Area (Sq.mt.)	Tnmt (No.)
A (RESIDENTIAL)	1	132.61	2.58	130.03	130.03	130.03	01
Grand Total :	1	132.61	2.58	130.03	130.03	130.03	01

Proposal Basic Information

Proposal File No.	JNP/IBP/0044/W22/2021
Owner Name	SMT SUMITRA DEVI
Khata No	616
Plot No	1073
Village Name	Gomo
Use	Residential
SubUse	Bungalow/ Dwelling / Non Apartment

AREA STATEMENT

Version No.	1.0.56
Version Date	16/10/2020
Region	JHARKHAND URBAN LOCAL BODIES
District	KODERMA
Authority	JHUMRITILAIYA NAGAR PARISHAD
Inward No.	JNP/IBP/0044/W22/2021
Application Type	General Proposal
Project Type	Building Permission
Nature of Development	New
Location of Development Area	Old Area
Plot Use	Residential
Plot SubUse	Bungalow/ Dwelling / Non Apartment
Plot Nearby/Religious Structure	NA
Plot SubPlot No.	1073
North: Road Width	3.60
South: Road Width	3.65
East: Plot No.	- LAND OF SMT SUNITA DEVI
West: Plot No.	- LAND OF SMT ARTI DEVI

AREA DETAILS:

AREA OF PLOT (Minimum)	(A)	SQ.MT.
NET AREA OF PLOT (Gross Plot Area - Deduction from Gross Plot area)	(A-Deductions)	104.10
Deduction for Balance Plot Area (from Gross Plot Area)		
Common Plot		10.36
Total		10.36
BALANCE AREA OF PLOT (Net Plot Area - Recreational/Amenity space)	(A-Deductions)	93.74
PLOT AREA FOR COVERAGE (Net Plot Area)	(A-Deductions)	104.10
Plot Area for FAR (Net Plot Area + Road Widening Area)	(A-Deductions)	104.10

COVERAGE CHECK

Permissible Coverage area (70.00 %)	72.87
Proposed Coverage Area (62.22 %)	64.77
Total Prop. Coverage Area (62.22 %)	64.77
Balance coverage area (7.78 %)	8.10

FAR CHECK

Perm. FAR Area (1.50)	156.15
Total Perm. FAR area	156.15
Residential FAR	130.03
Proposed FAR Area	130.03
Total Proposed FAR Area	130.03
Consumed FAR (Factor)	1.25
Balance FAR Area	26.12

BUILT UP AREA CHECK

Total Proposed BuiltUp Area	132.61
ARCHITECT (Regd)	KIRAN KUMARI
ENGINEER (Regd)	
SUPERVISOR (Regd)	
OWNER (Regd)	SMT SUMITRA DEVI
DEVELOPMENT AUTHORITY	LOCAL BODY

COLOR INDEX

PLOT BOUNDARY	Black
ABUTTING ROAD	Red
PROPOSED CONSTRUCTION	Green
COMMON PLOT	Yellow
ROAD WIDENING AREA	Orange
EXISTING (To be retained)	Blue
EXISTING (To be demolished)	Light Blue

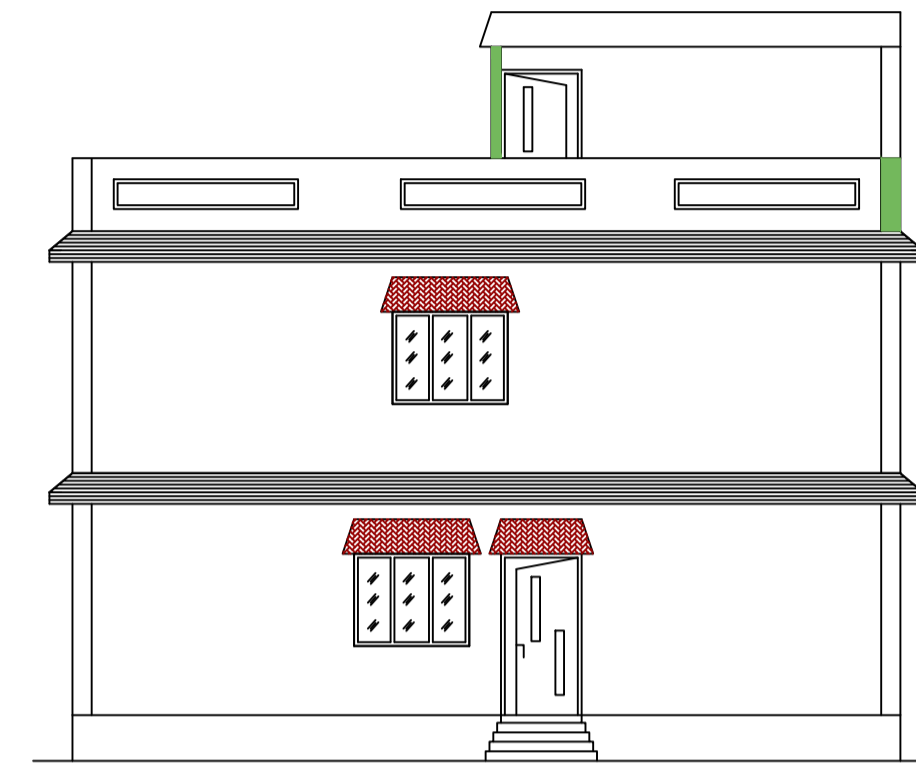

CROSS ELEVATION

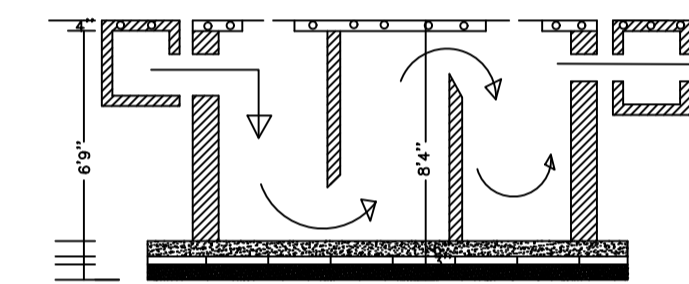

SECTION

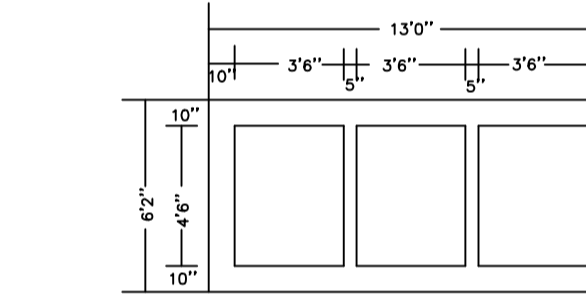

PLAN OF SEPTIC TANK

SITE PLAN

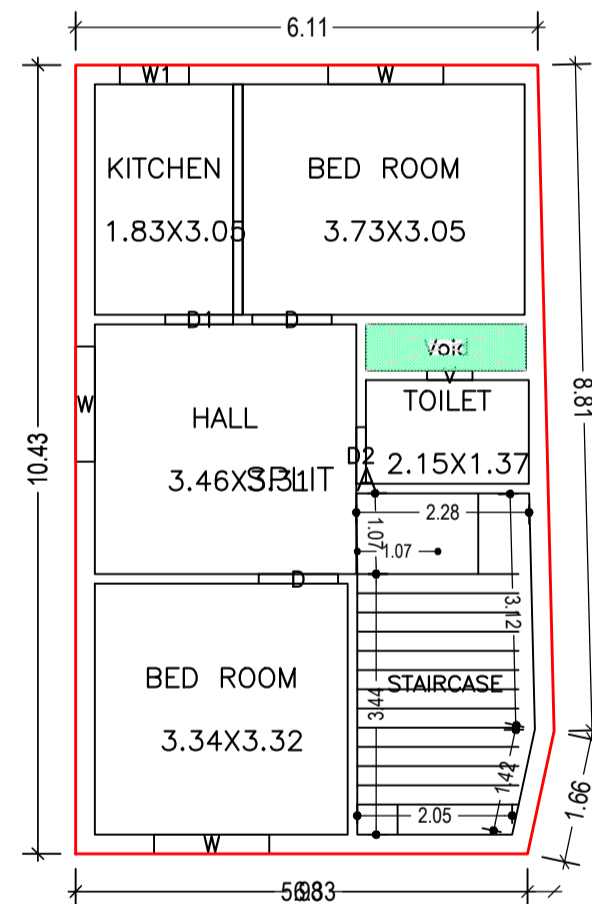

GROUND FLOOR PLAN (Proposed) (SCALE 1:100)

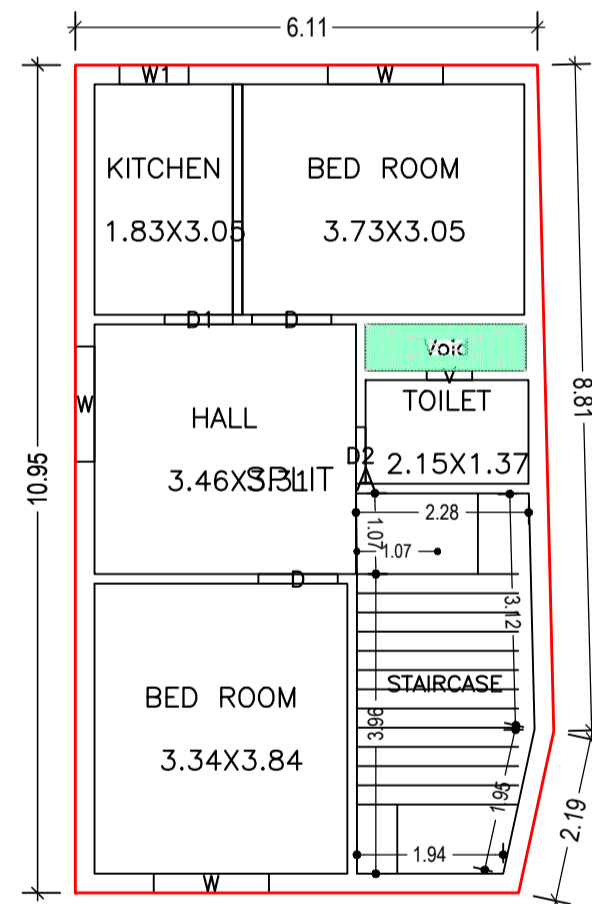

FIRST FLOOR PLAN (Proposed) (SCALE 1:100)

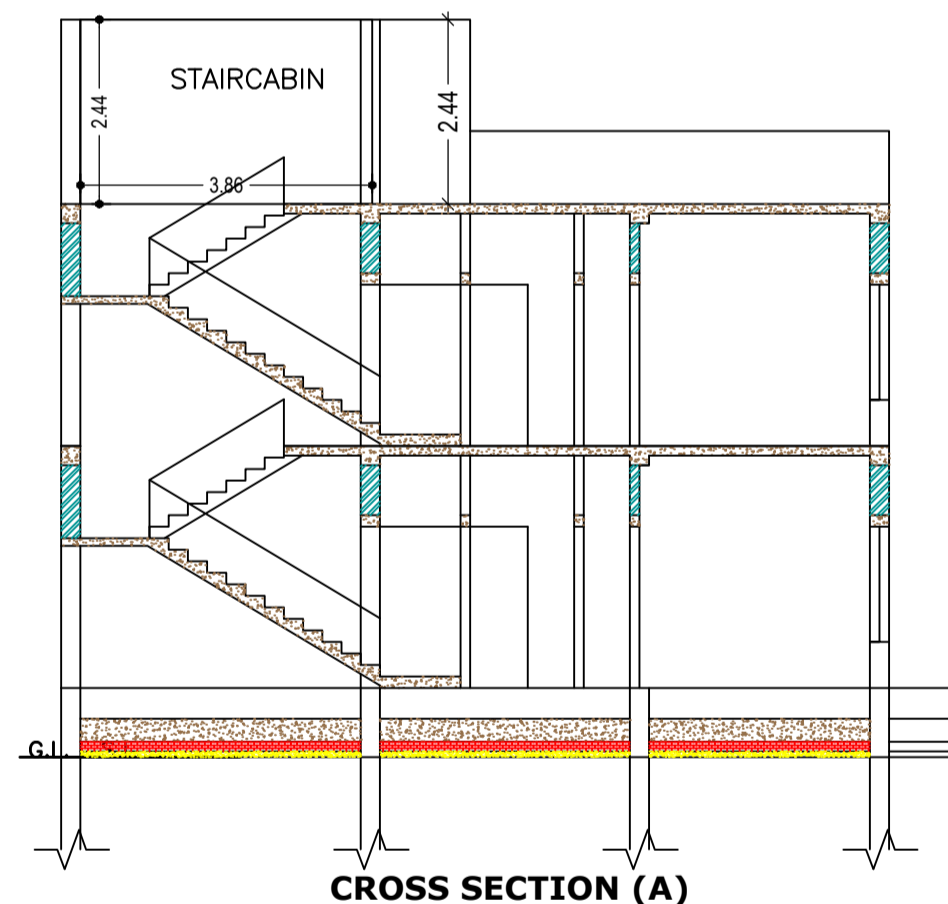

CROSS SECTION (A)

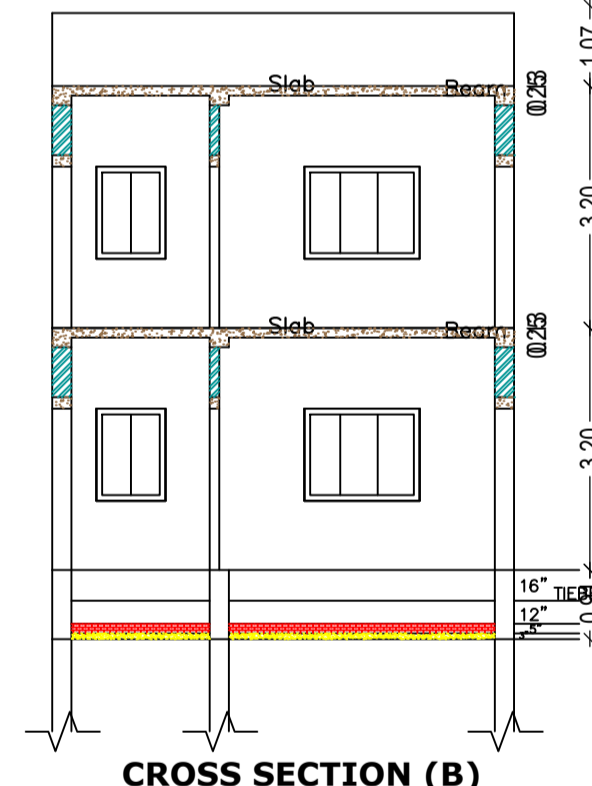

CROSS SECTION (B)

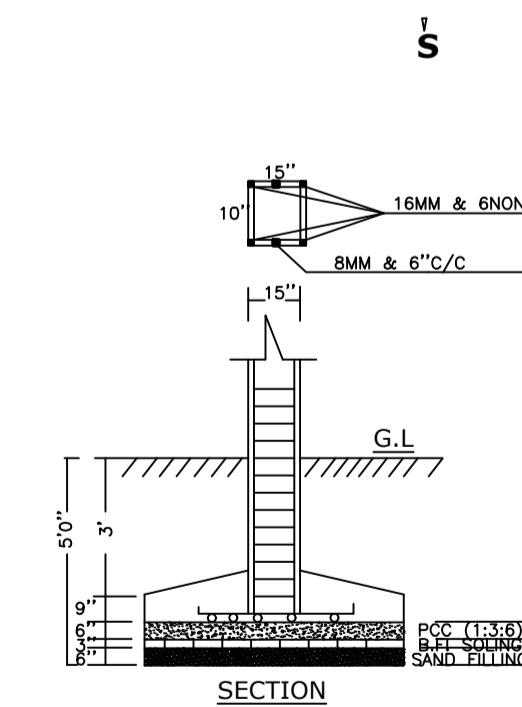

SECTION

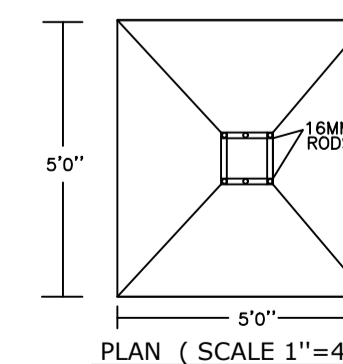

PLAN (SCALE 1''=4'')

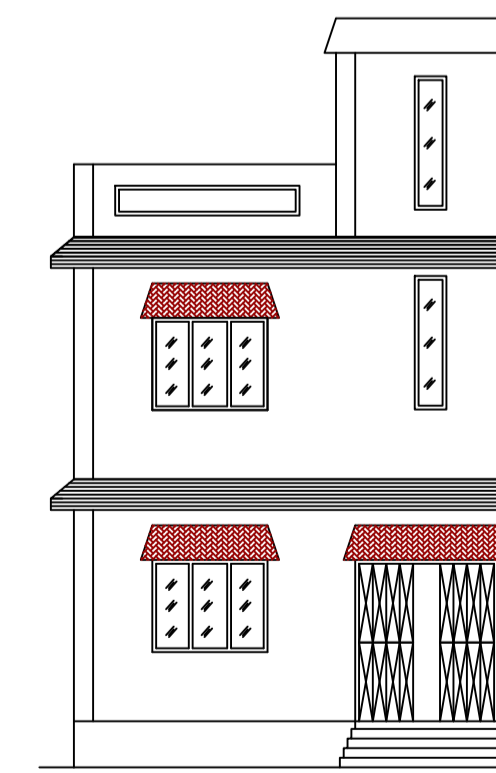

FRONT ELEVATION

Buildingwise Floor FAR Details

Floor Name	Building Name A (RESIDENTIAL)		Total	
	Proposed Built Up Area (Sq.mt.)	Proposed FAR Area (Sq.mt.)	Total Proposed Built Up Area (Sq.mt.)	Total FAR Area (Sq.mt.)
Ground Floor	64.77	63.48	64.77	63.48
First Floor	67.84	66.55	67.84	66.55
Terrace Floor	0.00	0.00	0.00	0.00
Total :	132.61	130.03	132.61	130.03

Building USE/SUBUSE Details

Building Name	Building Use	Building SubUse	Building Structure
A (RESIDENTIAL)	Residential	Bungalow/ Dwelling / Non Apartment	Non-Highrise

Building :A (RESIDENTIAL)

Floor Name	Total Built Up Area (Sq.mt.)	Deductions (Area in Sq.mt.)	Proposed FAR Area (Sq.mt.)	Total FAR Area (Sq.mt.)	Total Consumed Additional FAR Area (Sq.mt.)	Tnmt (No.)
Ground Floor	64.77	1.29	63.48	63.48	63.48	01
First Floor	67.84	1.29	66.55	66.55	66.55	00
Terrace Floor	0.00	0.00	0.00	0.00	0.00	00
Total :	132.61	2.58	130.03	130.03	130.03	01
Total Number of Same Buildings	1					
Total :	132.61	2.58	130.03	130.03	130.03	01

SCHEDULE OF DOOR:

BUILDING NAME	NAME	LENGTH	HEIGHT	NOS
A (RESIDENTIAL)	D2	0.75	2.10	02
A (RESIDENTIAL)	D1	0.90	2.10	02
A (RESIDENTIAL)	D	1.05	2.10	04

SCHEDULE OF WINDOW/VENTILATION:

BUILDING NAME	NAME	LENGTH	HEIGHT	NOS
A (RESIDENTIAL)	V	0.60	0.75	02
A (RESIDENTIAL)	W1	0.91	1.20	02
A (RESIDENTIAL)	W	1.52	1.20	06

UnitBUA Table for Building :A (RESIDENTIAL)

FLOOR	Name	UnitBUA Type	UnitBUA Area	Carpet Area	No. of Rooms	No. of Tenement
GROUND FLOOR PLAN	SPLIT A	FLAT	89.42	88.65	5	1
FIRST FLOOR PLAN	SPLIT A	FLAT	0.00	0.00	5	0
Total:	-	-	89.42	88.65	10	1