

(Scale - 1:200)

FAR & Tenement Details (Table 4c-1)

Building	No. of Same Bldg	Total Built Up Area (Sq.mt.)	Deductions (Area in Sq.mt.) Parking	Proposed FAR Area (Sq.mt.) Resi.	Total FAR Area (Sq.mt.)	Total Consumed Additional FAR Area (Sq.mt.)	Tnmt (No.)
A (RESIDENTIAL)	1	247.84	18.09	229.75	229.75	229.75	01
Grand Total :	1	247.84	18.09	229.75	229.75	229.75	01

Proposal Basic Information

Proposal File No.	JNP/IBP/0042/W04/2021
Owner Name	SRI BASUDEV YADAV
Khata No	397
Plot No	5962
Village Name	Tilaiya
Use	Residential
SubUse	Bungalow/ Dwelling / Non Apartment

AREA STATEMENT	VERSION NO. : 1.0.56
JHUMRITILAIYA NAGAR	VERSION DATE: 16/10/2020
PARISHAD	
PROJECT DETAIL:	
Region: JHARKHAND URBAN LOCAL BODIES	Plot Use: Residential
District: KODERMA	Plot SubUse: Bungalow/ Dwelling / Non Apartment
Authority: JHUMRITILAIYA NAGAR PARISHAD	PlotNearbyReligiousStructure: NA
Inward No: JNP/IBP/0042/W04/2021	Plot/SubPlot No: 5962
Application Type: General Proposal	North: Plot No. - LAND OF SRI SURESH YADAV
Project Type: Building Permission	South: Plot No. - LAND OF SRI MOHAN YADAV
Nature of Development: New	East: Road Width - 4.2
Location of Development Area: Old Area	West: Plot No. - 5963, 5964
AREA DETAILS:	SQ.MT.
AREA OF PLOT (Minimum)	(A) 220.97
NET AREA OF PLOT(Gross Plot Area - Deduction from Gross Plot area)	(A-Deductions) 220.97
Deduction for Balance Plot Area(from Gross Plot Area)	
Common Plot	
Total	28.69
BALANCE AREA OF PLOT(Net Plot Area - Recreational/Amenity space)	(A-Deductions) 192.28
PLOT AREA FOR COVERAGE(Net Plot Area)	(A-Deductions) 220.97
Plot Area for FAR (Net Plot Area + RoadWidening Area)	(A-Deductions) 220.97
COVERAGE CHECK	
Permissible Coverage area ( 70.00 % )	154.68
Proposed Coverage Area ( 56.08 % )	123.92
Total Prop. Coverage Area ( 56.08 % )	123.92
Balance coverage area ( 13.92 % )	30.76
FAR CHECK	
Perm. FAR Area ( 1.50 )	331.46
Total Perm. FAR area	331.46
Residential FAR	229.75
Proposed FAR Area	229.75
Total Proposed FAR Area	229.75
Consumed FAR (Factor)	1.04
Balance FAR Area	101.71
BUILT UP AREA CHECK	
Total Proposed BuiltUp Area	247.84
ARCHITECT (Regd)	KIRAN KUMARI
ENGINEER (Regd)	
SUPERVISOR (Regd)	
OWNER (Regd)	SRI BASUDEV YADAV
DEVELOPMENT AUTHORITY	LOCAL BODY

COLOR INDEX	
PLOT BOUNDARY	Black
ABUTTING ROAD	Green
PROPOSED CONSTRUCTION	Red
COMMON PLOT	White
ROAD WIDENING AREA	Yellow
EXISTING (To be retained)	Blue
EXISTING (To be demolished)	Orange

Buildingwise Floor FAR Details

Floor Name	Building Name A (RESIDENTIAL)		Total	
	Proposed Built Up Area (Sq.mt.)	Proposed FAR Area (Sq.mt.)	Total Proposed Built Up Area (Sq.mt.)	Total FAR Area (Sq.mt.)
Ground Floor	123.92	105.83	123.92	105.83
First Floor	123.92	123.92	123.92	123.92
Terrace Floor	0.00	0.00	0.00	0.00
Total :	247.84	229.75	247.84	229.75

Building USE/SUBUSE Details

Building Name	Building Use	Building SubUse	Building Structure
A (RESIDENTIAL)	Residential	Bungalow/ Dwelling / Non Apartment	Non-Highrise

LTP NAME AND SIGNATURE	STRUCTURAL ENG'S NAME AND SIGNATURE	BUILDER NAME AND SIGNATURE	DIGITAL SIGNATURE
KIRAN KUMARI JNP/ENG/0001/2019			

Proposal Basic Information

Proposal File No.	JNP/IBP/0042/W04/2021
Owner Name	SRI BASUDEV YADAV
Khata No	397
Plot No	5962
Village Name	Tilaiya
Use	Residential
SubUse	Bungalow/ Dwelling / Non Apartment

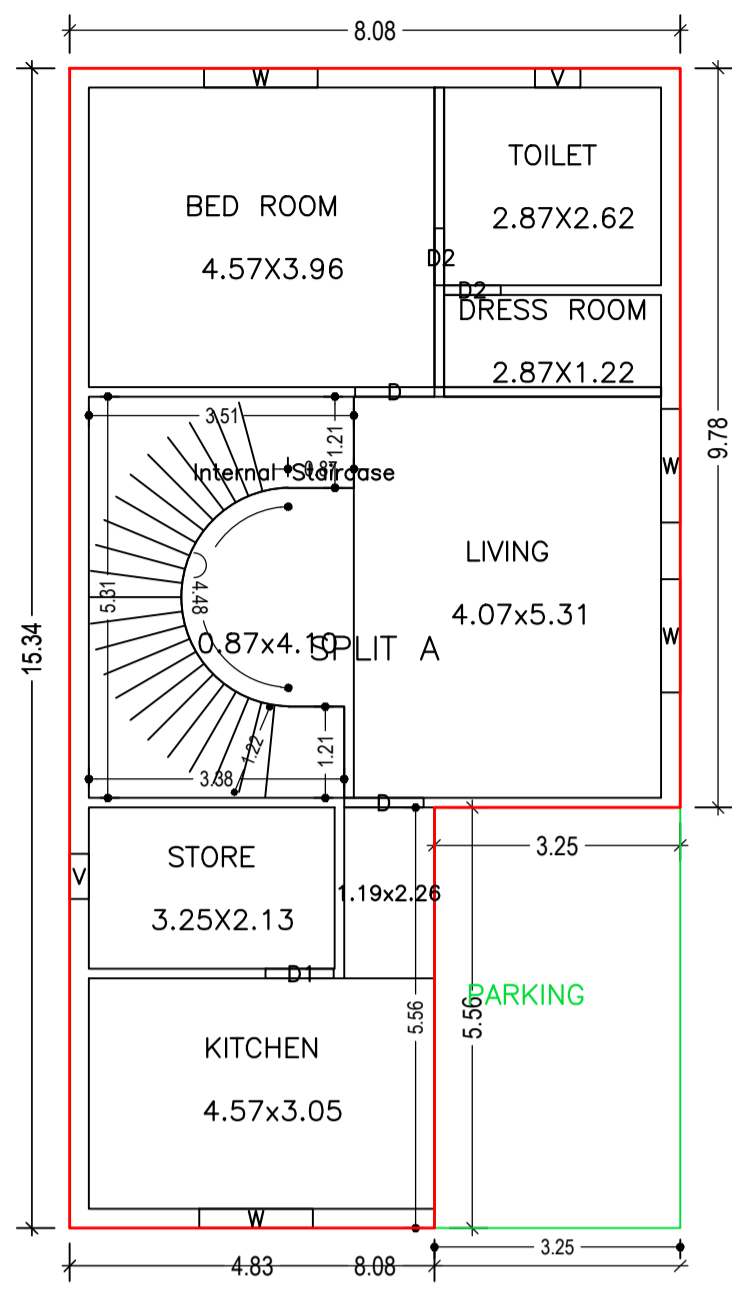

GROUND FLOOR PLAN (Proposed) (SCALE 1:100)

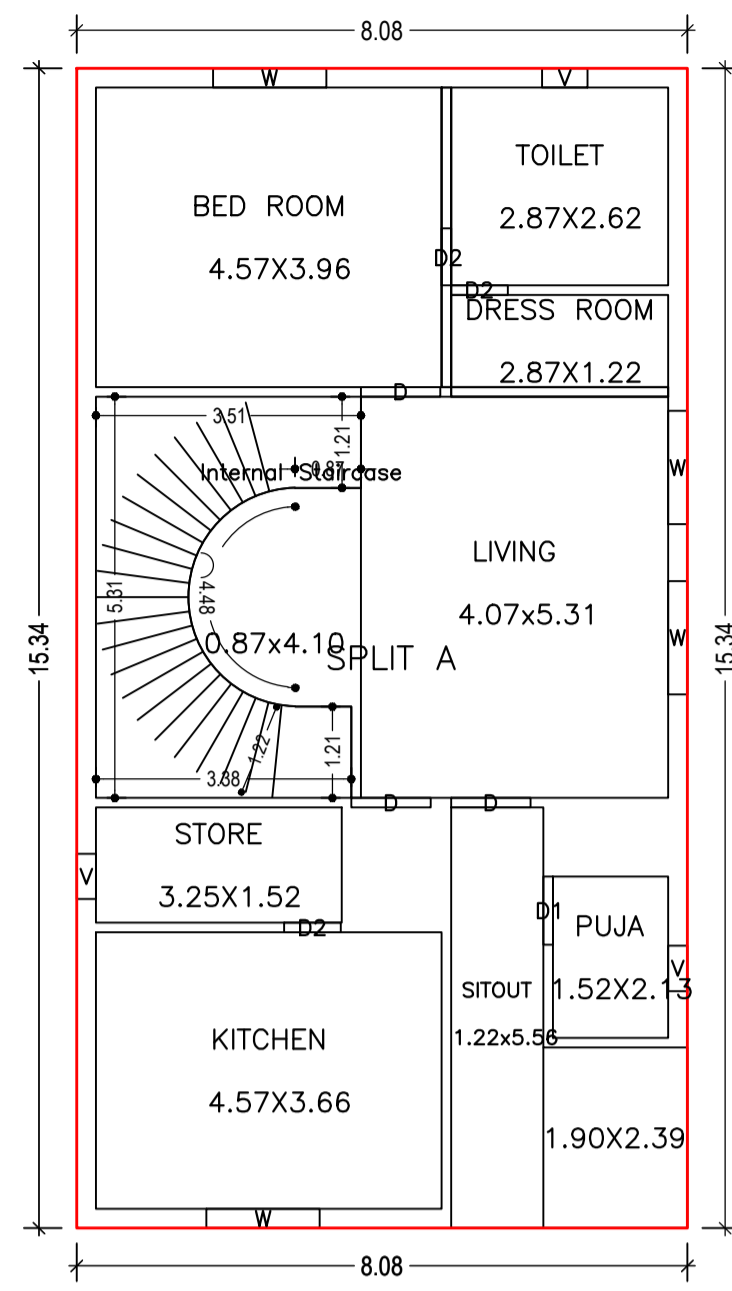

FIRST FLOOR PLAN (Proposed) (SCALE 1:100)

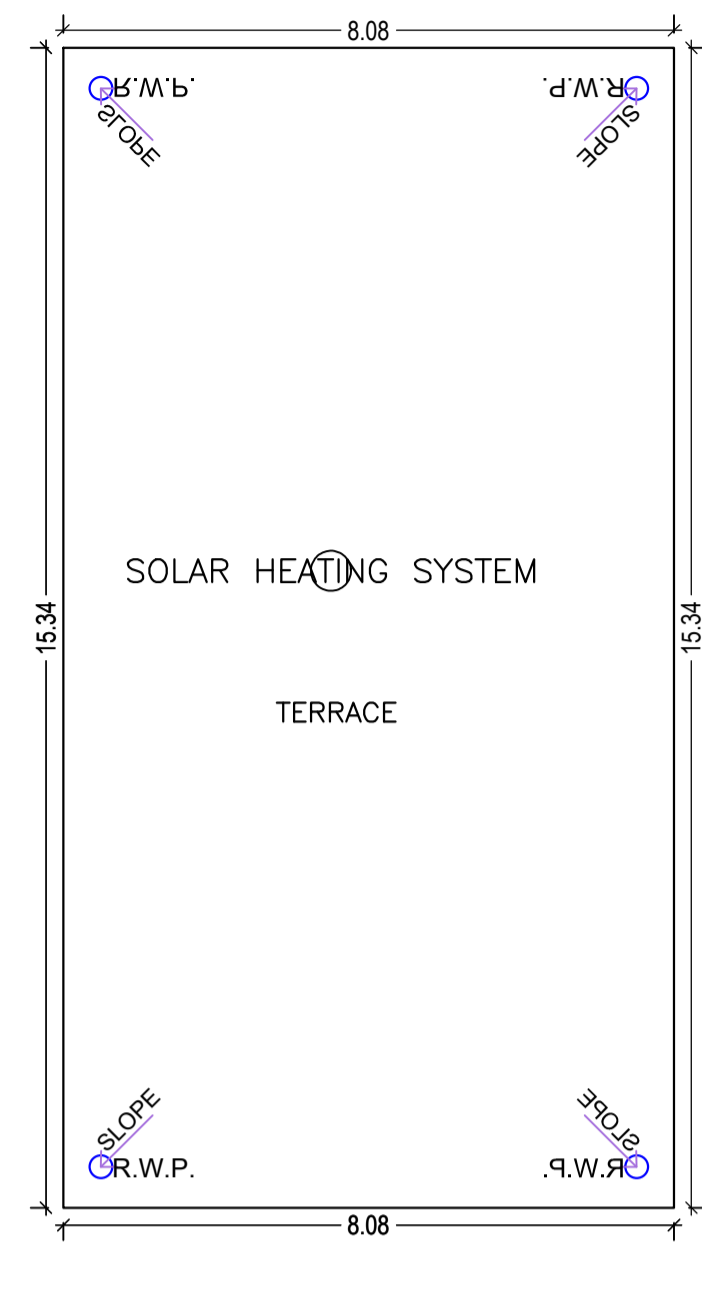

TERRACE FLOOR PLAN (SCALE 1:100)

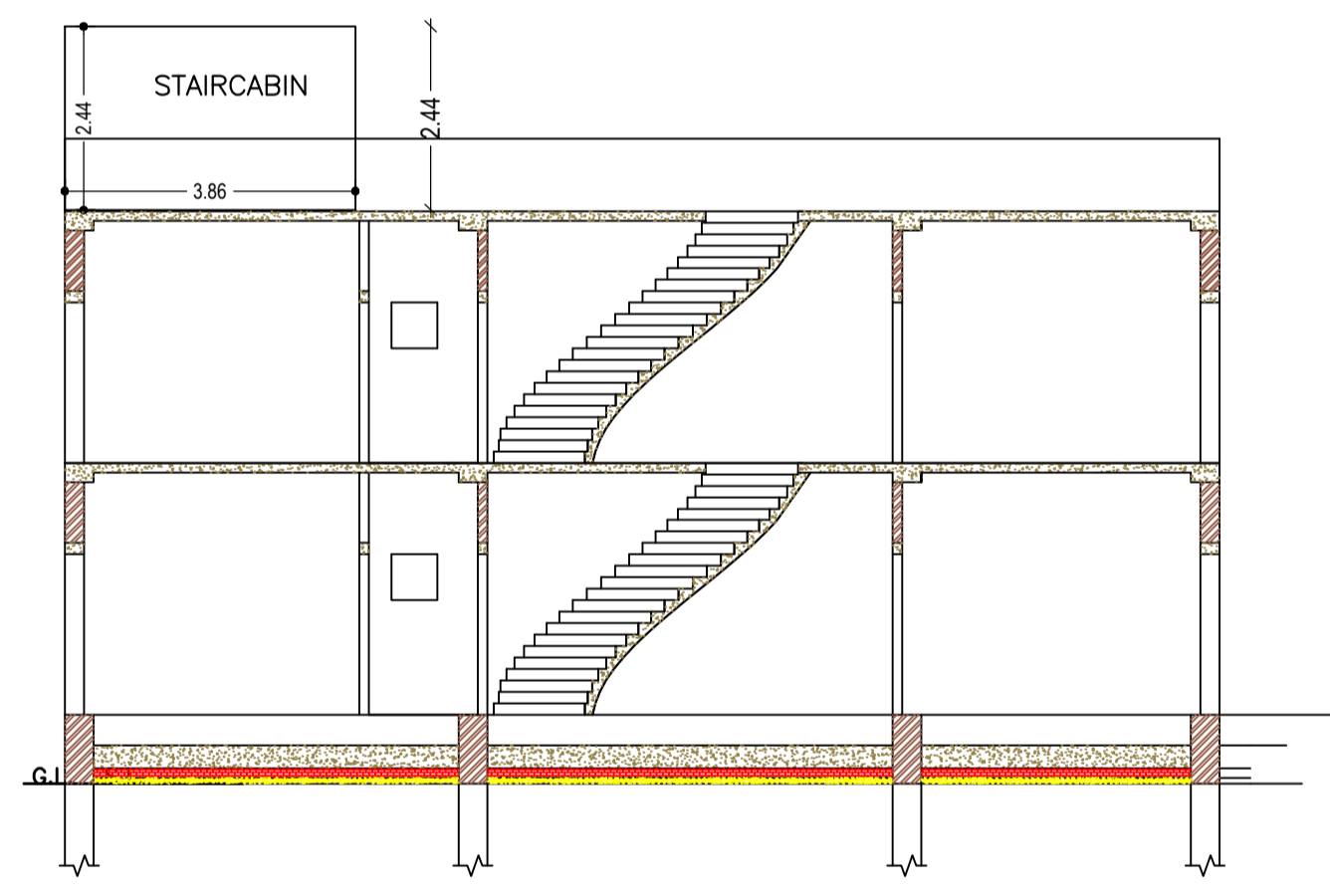
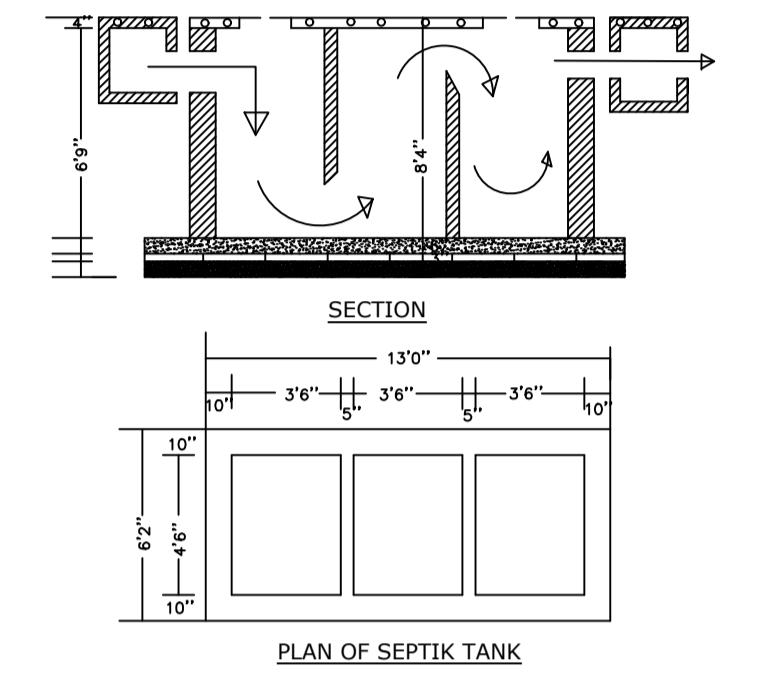

CROSS SECTION (A)

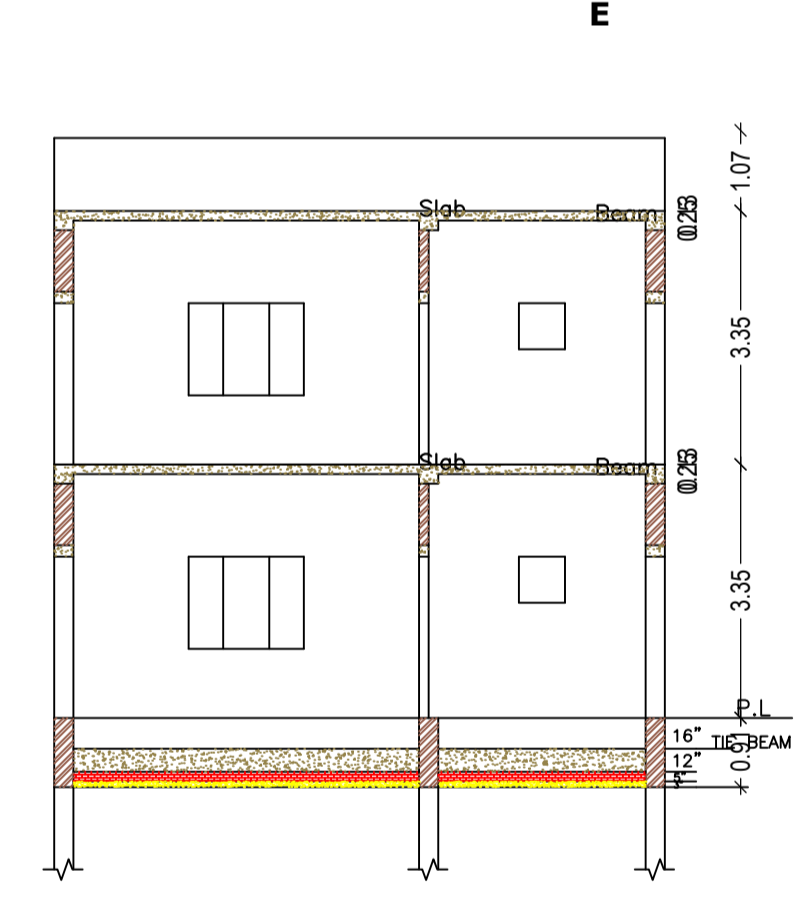

CROSS SECTION (B)

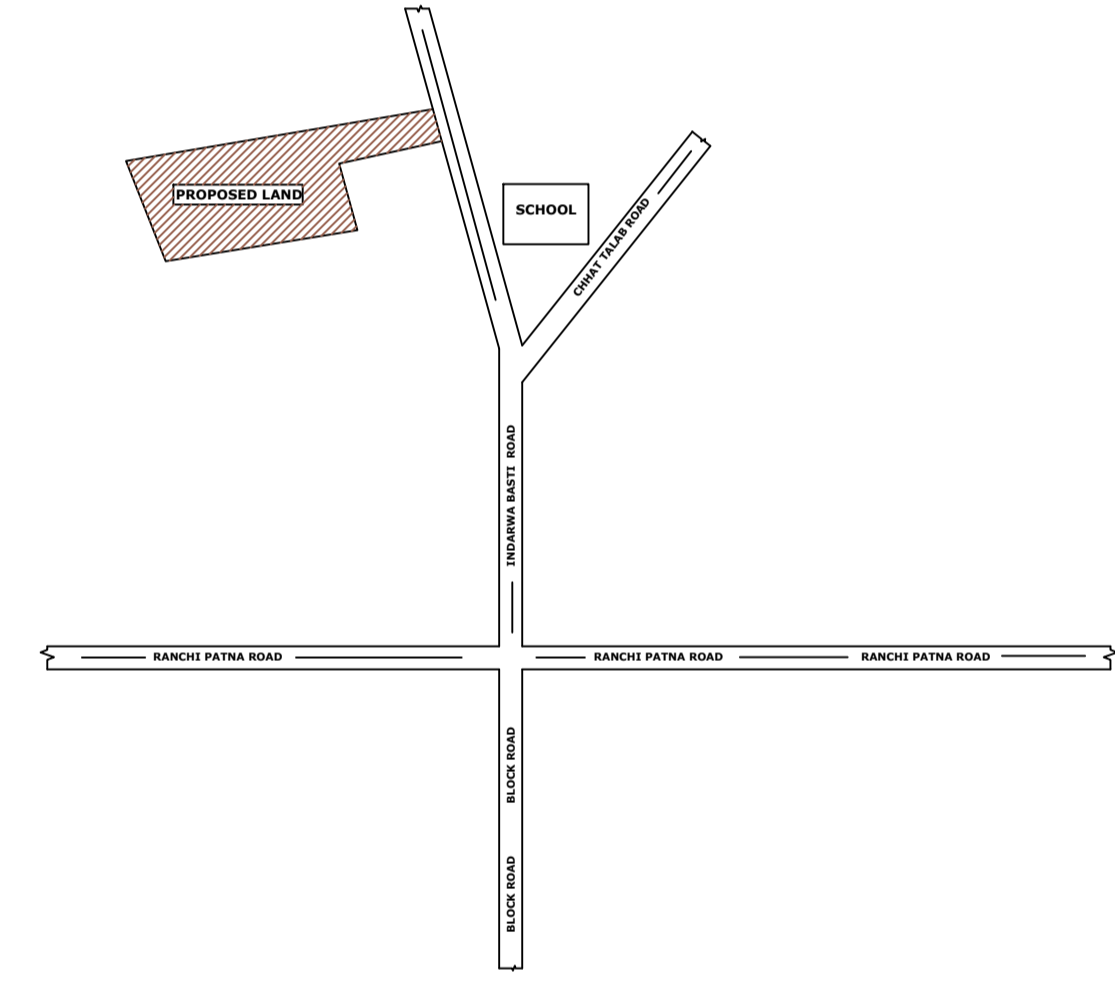

LOCATION PLAN (SCALE -1''16')

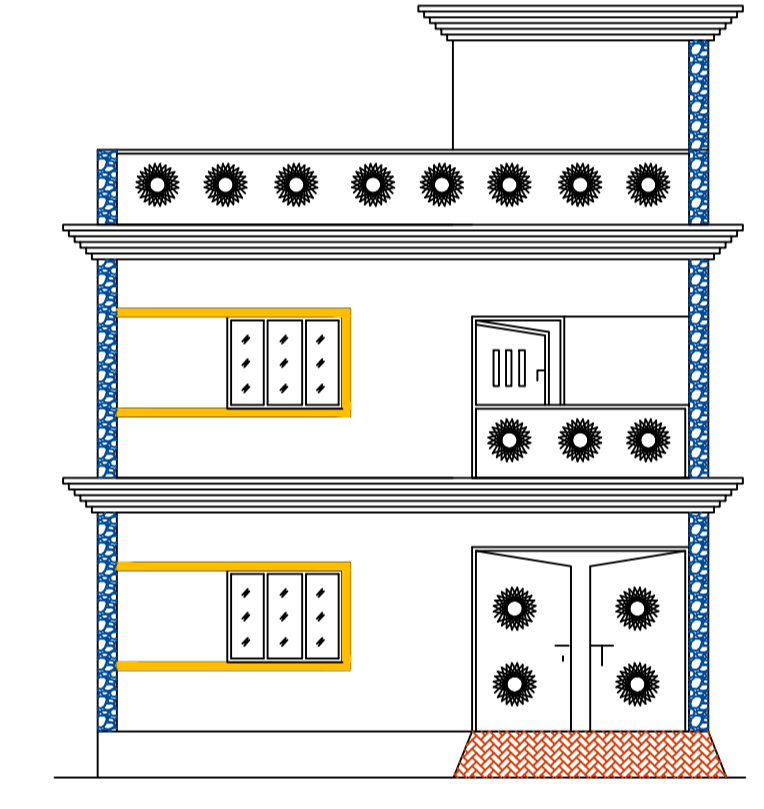

FRONT ELEVATION

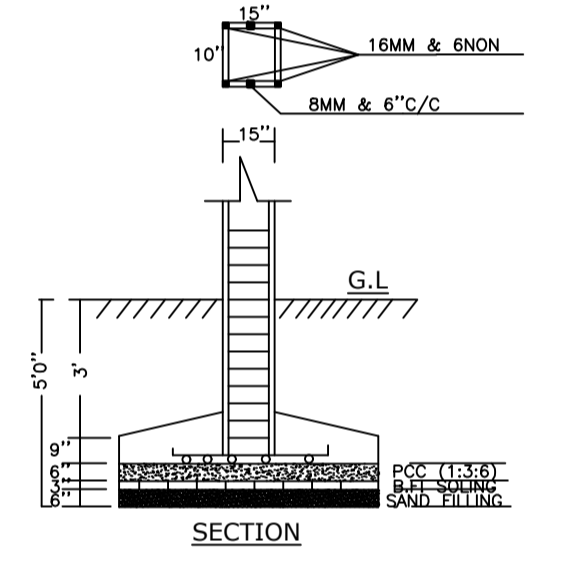

SECTION

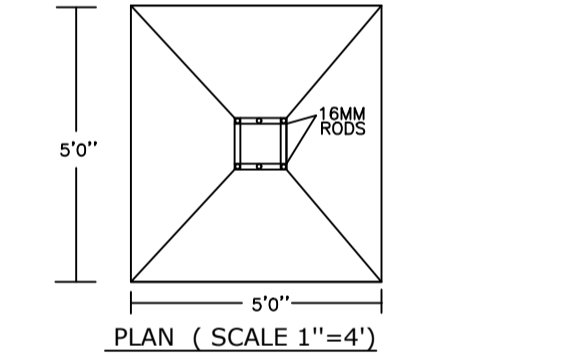

PLAN (SCALE 1''=4')

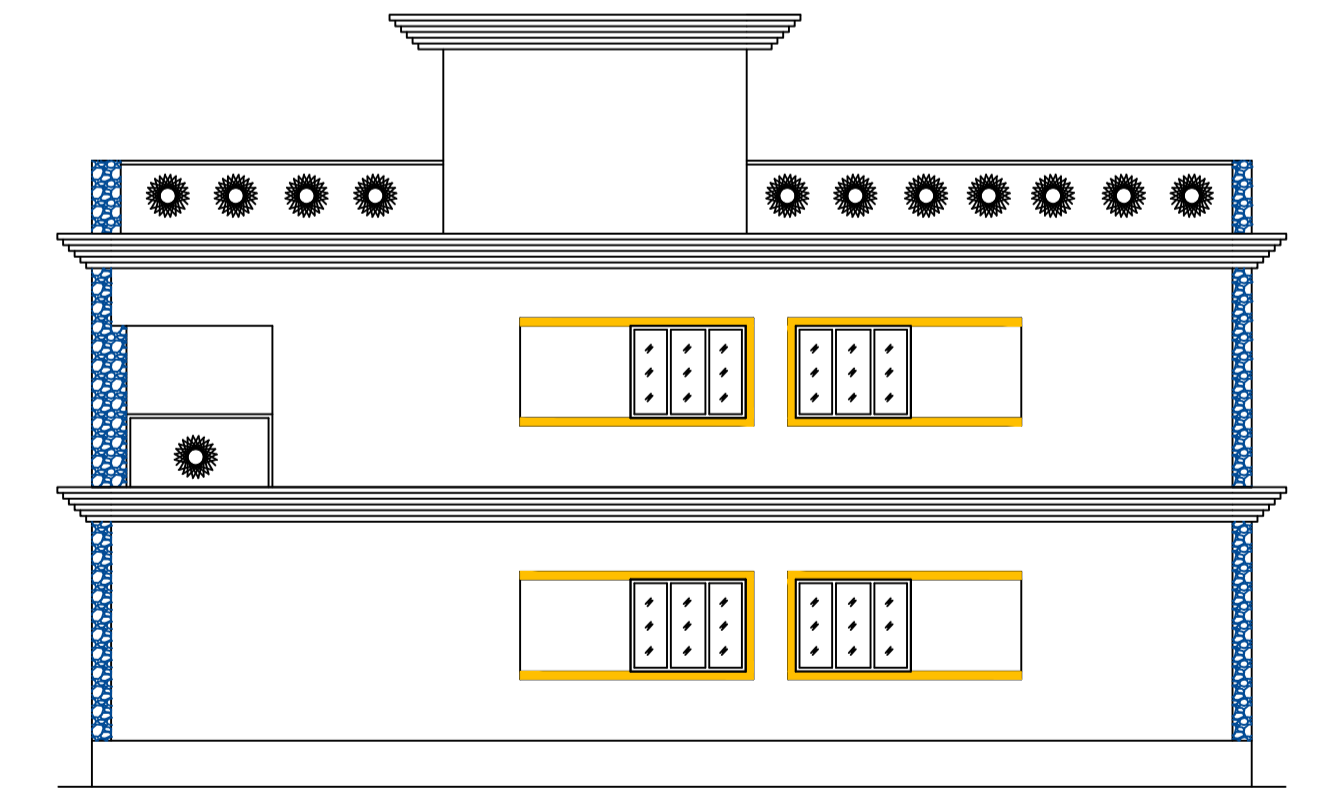

CROSS ELEVATION

Building :A (RESIDENTIAL)

Floor Name	Total Built Up Area (Sq.mt.)	Deductions (Area in Sq.mt.)	Proposed FAR Area (Sq.mt.)	Total FAR Area (Sq.mt.)	Total Consumed Additional FAR Area (Sq.mt.)	Trmt (No.)
Ground Floor	123.92	18.09	105.83	105.83	105.83	01
First Floor	123.92	0.00	123.92	123.92	123.92	00
Terrace Floor	0.00	0.00	0.00	0.00	0.00	00
Total :	247.84	18.09	229.75	229.75	229.75	01
Total Number of Same Buildings :	1					
Total :	247.84	18.09	229.75	229.75	229.75	01

SCHEDULE OF DOOR:

BUILDING NAME	NAME	LENGTH	HEIGHT	NOS
A (RESIDENTIAL)	D2	0.75	2.10	05
A (RESIDENTIAL)	D1	0.90	2.10	02
A (RESIDENTIAL)	D	1.05	2.10	05

SCHEDULE OF WINDOW/VENTILATION:

BUILDING NAME	NAME	LENGTH	HEIGHT	NOS
A (RESIDENTIAL)	V	0.60	0.90	05
A (RESIDENTIAL)	W	1.50	1.20	08

UnitBUA Table for Building :A (RESIDENTIAL)

FLOOR	Name	UnitBUA Type	UnitBUA Area	Carpet Area	No. of Rooms	No. of Tenement
GROUND FLOOR PLAN	SPLIT A	FLAT	209.60	207.87	6	1
FIRST FLOOR PLAN	SPLIT A	FLAT	0.00	0.00	8	0
Total:	-	-	209.60	207.87	14	1

LTP NAME AND SIGNATURE	STRUCTURAL ENG'S NAME AND SIGNATURE	BUILDER NAME AND SIGNATURE	DIGITAL SIGNATURE
KIRAN KUMARI JNP/ENG/0001/2019			