

Project Title :  
 PROPOSED BUILDING PLAN FOR:- SRI RANJIT KUMAR GUPTA . S/O - SRI SHARDHANAND PRASAD . MAUZA-TELIAYA .  
 WARD NO- 15 . P.S-TELIAYA . P.S NO- 244 . KHATA NO- 382 . PLOT NO- 5541 . DISTT-KODERMA ( JHARAKHAND )

DATE 07-06-2021  
 SHEET NO. 1

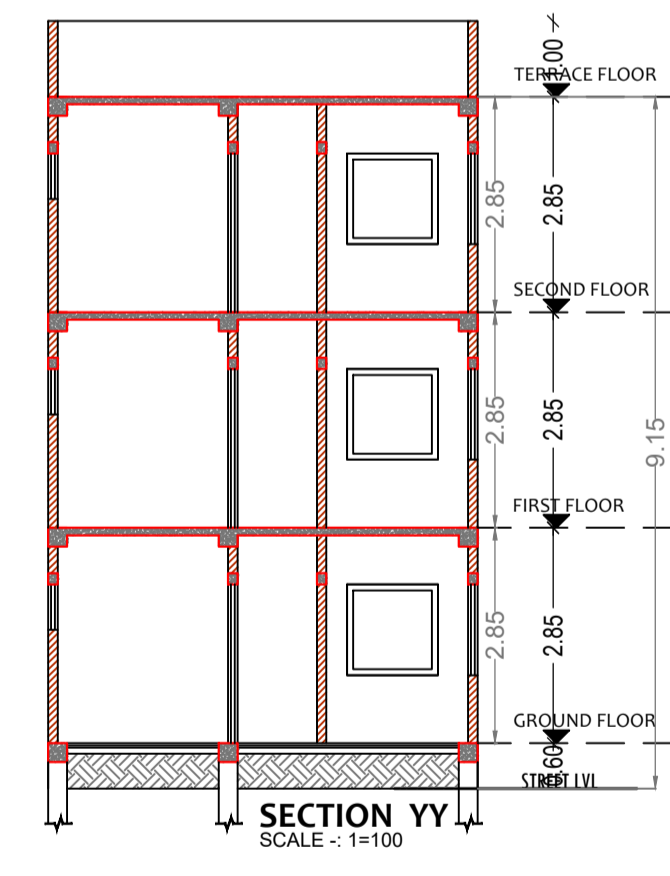
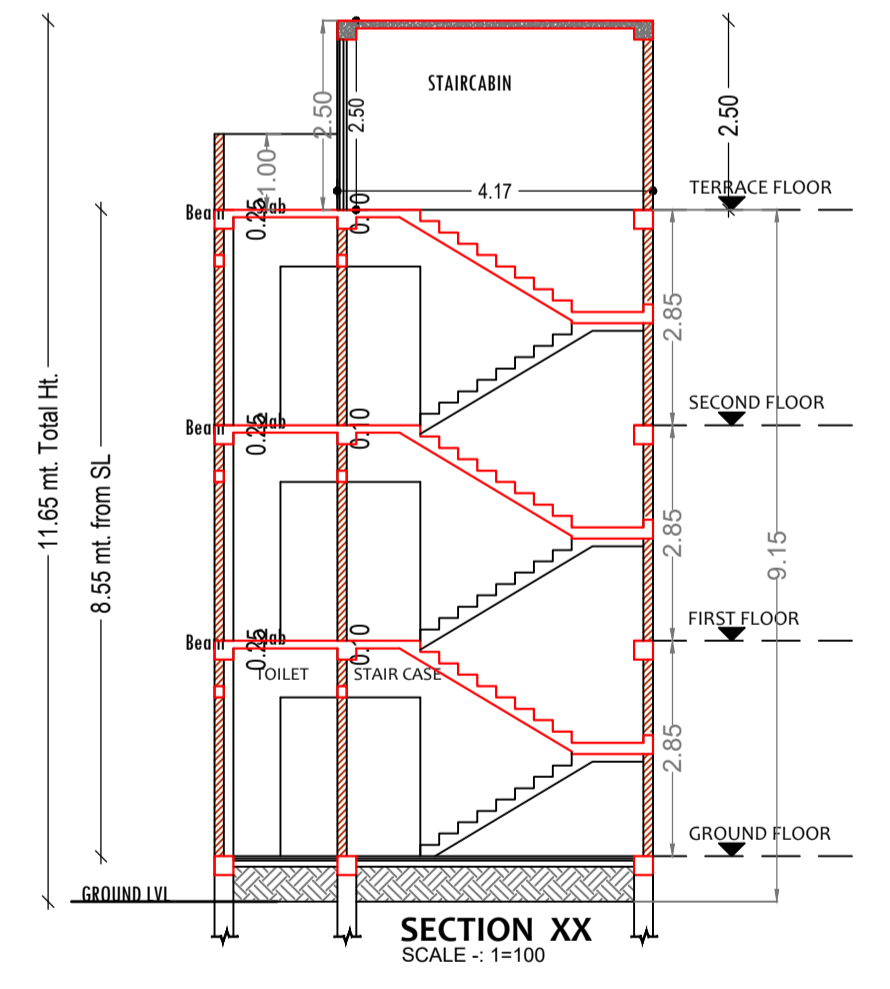
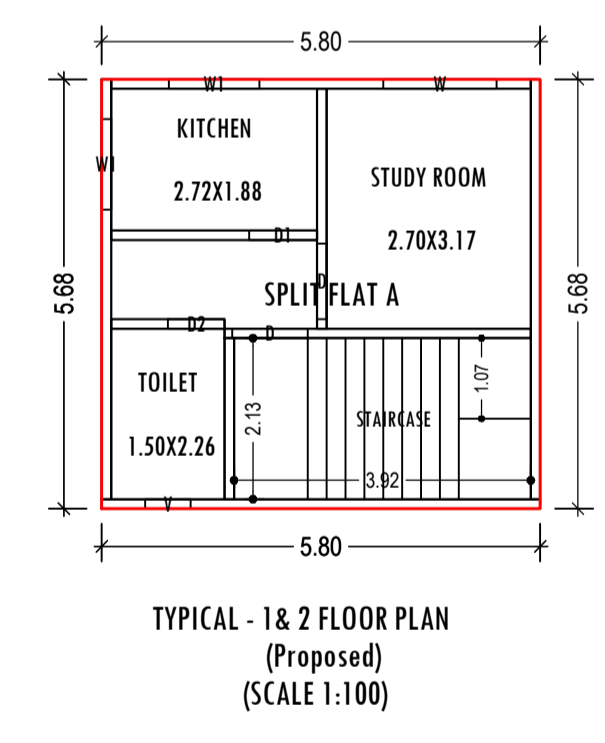
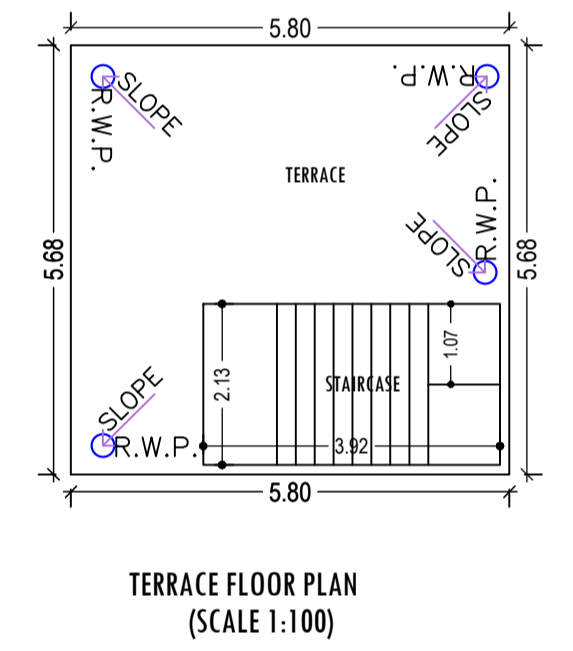
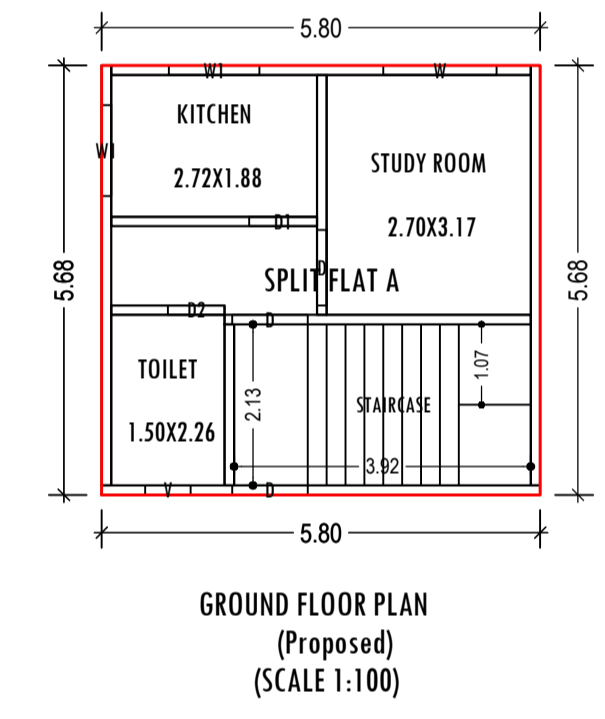
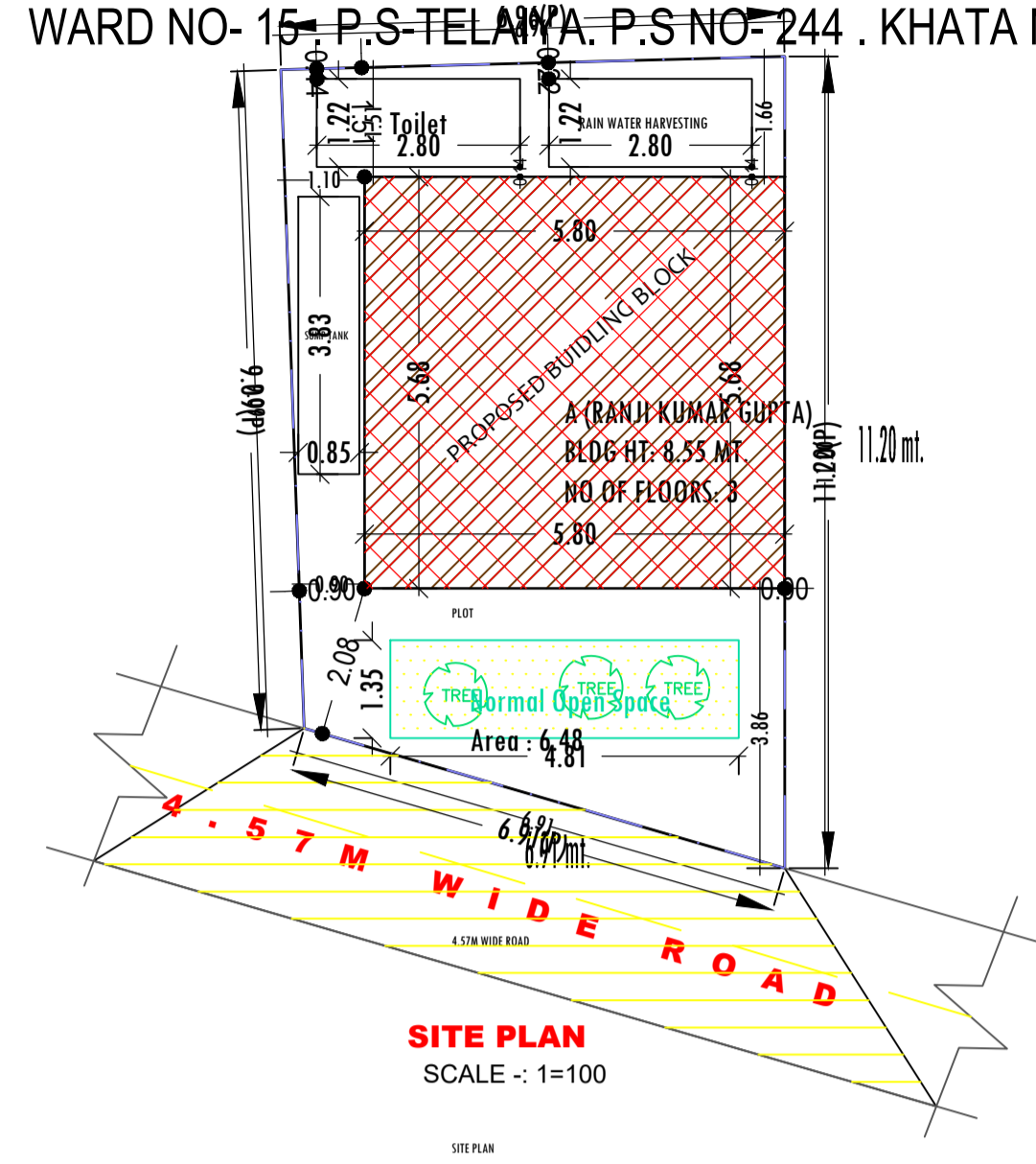

**Building -A (RANJI KUMAR GUPTA)**

Floor Name	Total Built Up Area (Sq.mt.)	Proposed FAR Area (Sq.mt.) Resi.	Total FAR Area (Sq.mt.)	Total Consumed Additional FAR Area (Sq.mt.)	Tnmt (No.)
Ground Floor	32.93	32.93	32.93	32.93	01
First Floor	32.93	32.93	32.93	32.93	00
Second Floor	32.93	32.93	32.93	32.93	00
Terrace Floor	0.00	0.00	0.00	0.00	00
<b>Total :</b>	<b>98.79</b>	<b>98.79</b>	<b>98.79</b>	<b>98.79</b>	<b>01</b>
Total Number of Same Buildings	1				
<b>Total :</b>	<b>98.79</b>	<b>98.79</b>	<b>98.79</b>	<b>98.79</b>	<b>01</b>

**SCHEDULE OF DOOR:**

BUILDING NAME	NAME	LENGTH	HEIGHT	NOS
A (RANJI KUMAR GUPTA)	D2	0.75	2.13	03
A (RANJI KUMAR GUPTA)	D1	0.90	2.13	03
A (RANJI KUMAR GUPTA)	D	1.00	2.13	06

**SCHEDULE OF WINDOW/VENTILATION:**

BUILDING NAME	NAME	LENGTH	HEIGHT	NOS
A (RANJI KUMAR GUPTA)	V	0.60	0.60	03
A (RANJI KUMAR GUPTA)	W1	1.20	1.20	06
A (RANJI KUMAR GUPTA)	W	1.50	1.20	03

**UnitBUA Table for Building -A (RANJI KUMAR GUPTA)**

FLOOR	Name	UnitBUA Type	UnitBUA Area	Carpet Area	No. of Rooms	No. of Tenement
GROUND FLOOR PLAN	SPLIT FLAT A	FLAT	65.30	60.21	3	1
TYPICAL - 1 & 2 FLOOR PLAN	SPLIT FLAT A	FLAT	0.00	0.00	3	0
<b>Total:</b>	-	-	<b>65.30</b>	<b>60.21</b>	<b>9</b>	<b>1</b>

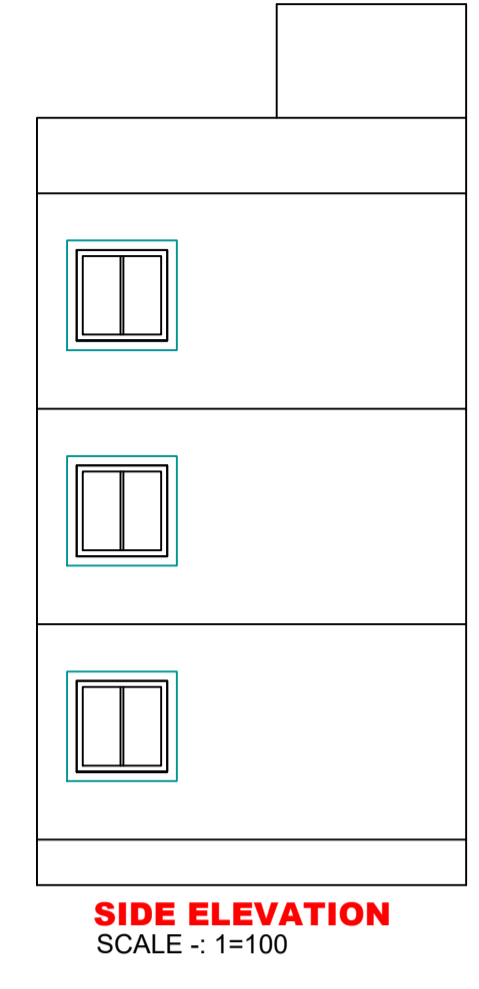

**FAR & Tenement Details (Table 4c-1)**

Building	No. of Same Bldg	Total Built Up Area (Sq.mt.)	Proposed FAR Area (Sq.mt.) Resi.	Total FAR Area (Sq.mt.)	Total Consumed Additional FAR Area (Sq.mt.)	Tnmt (No.)
A (RANJI KUMAR GUPTA)	1	98.79	98.79	98.79	98.79	01
<b>Grand Total :</b>	<b>1</b>	<b>98.79</b>	<b>98.79</b>	<b>98.79</b>	<b>98.79</b>	<b>01</b>

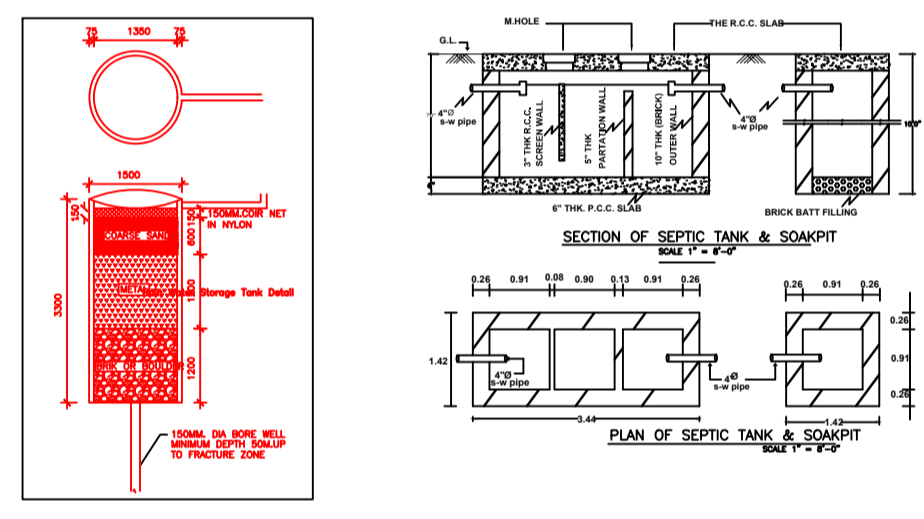
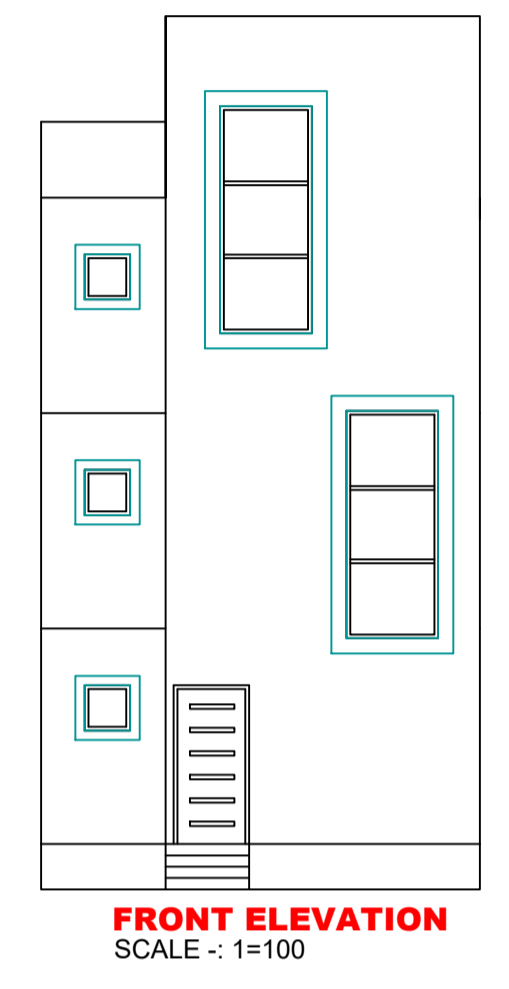

**AREA STATEMENT**  
 JHUMRITILAIYA NAGAR PARISHAD

**VERSION NO. :- 1.0.55**  
**VERSION DATE:- 16/10/2020**

**PROJECT DETAIL:**  
 Region: JHARKHAND URBAN LOCAL BODIES  
 District: KODERMA  
 Authority: JHUMRITILAIYA NAGAR PARISHAD  
 Inward No: JNP/IB/0033/W15/2021  
 Application Type: General Proposal  
 Project Type: Building Permission  
 Nature of Development: New  
 Location of Development Area: Old Area

**Plot Use: Residential**  
**Plot SubUse: Bungalow/ Dwelling / Non Apartment**  
**PlotNearbyReligiousStructure: NA**  
**PlotSubPlot No: 5541**  
**North: Plot No. - SARIKA KUMARI GUPTA**  
**South: Plot No. - LAND OF VIKASH KUMAR**  
**East: Road Width - 4.57M WIDE ROAD**  
**West: Plot No. - RANJAN SAW**

**AREA DETAILS:**

AREA OF PLOT (Minimum)	(A)	SQ.MT.
NET AREA OF PLOT(Gross Plot Area - Deduction from Gross Plot area)	(A-Deductions)	68.75
<b>Deduction for Balance Plot Area(from Gross Plot Area)</b>		
Common Plot		6.48
Total		6.48
BALANCE AREA OF PLOT(Net Plot Area - Recreational/Amenity space)	(A-Deductions)	62.27
PLOT AREA FOR COVERAGE(Net Plot Area)	(A-Deductions)	68.75
Plot Area for FAR (Net Plot Area + RoadWidening Area)	(A-Deductions)	68.75

**COVERAGE CHECK**

Permissible Coverage area ( 70.00 % )	48.13
Proposed Coverage Area ( 47.90 % )	32.93
Total Prop. Coverage Area ( 47.9 % )	32.93
Balance coverage area ( 22.11 % )	15.20

**FAR CHECK**

Perm. FAR Area ( 1.50 )	103.13
Total Perm. FAR area	103.13
Residential FAR	98.80
Proposed FAR Area	98.80
Total Proposed FAR Area	98.80
Consumed FAR (Factor)	1.44
Balance FAR Area	4.33

**BUILT UP AREA CHECK**

Total Proposed BuiltUp Area	98.79
-----------------------------	-------

**ARCHITECT (Regd)** MD SHOAB ALAM  
**ENGINEER (Regd)**  
**SUPERVISOR (Regd)**  
**OWNER (Regd)** SRI RANJIT KUMAR GUPTA

**DEVELOPMENT AUTHORITY** LOCAL BODY

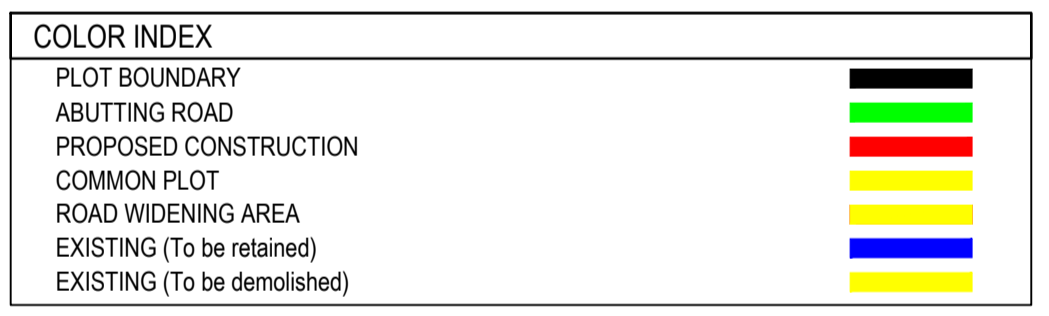

**Buildingwise Floor FAR Details**

Floor Name	Building Name A (RANJI KUMAR GUPTA)		Total	
	Proposed Built Up Area (Sq.mt.)	Proposed FAR Area (Sq.mt.)	Total Proposed Built Up Area (Sq.mt.)	Total FAR Area (Sq.mt.)
Ground Floor	32.93	32.93	32.93	32.93
First Floor	32.93	32.93	32.93	32.93
Second Floor	32.93	32.93	32.93	32.93
Terrace Floor	0.00	0.00	0.00	0.00
<b>Total :</b>	<b>98.79</b>	<b>98.79</b>	<b>98.79</b>	<b>98.79</b>

**Building USE/SUBUSE Details**

Building Name	Building Use	Building SubUse	Building Structure
A (RANJI KUMAR GUPTA)	Residential	Bungalow/ Dwelling / Non Apartment	Non-Highrise

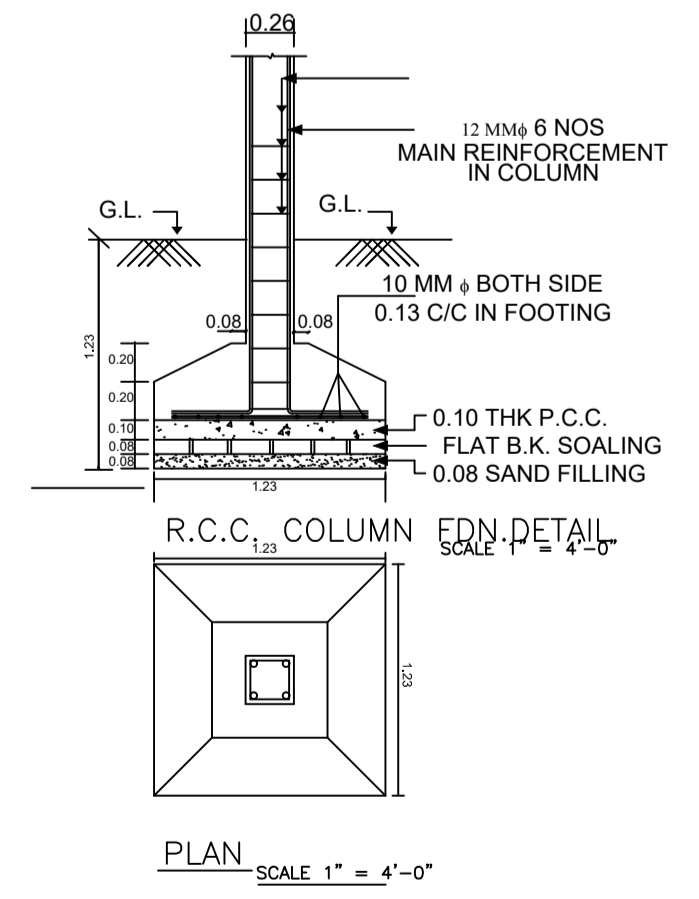
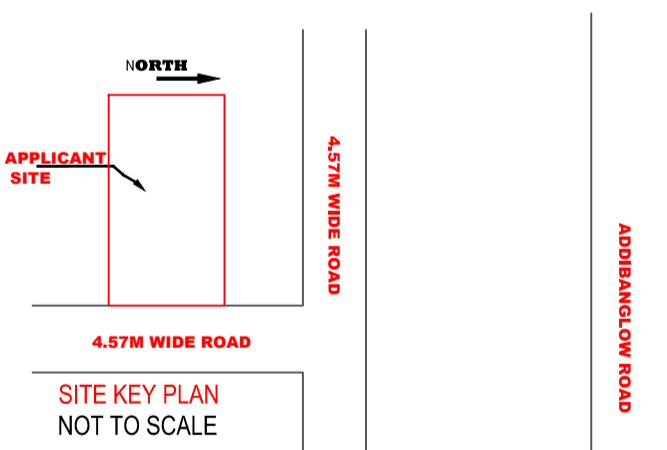

LTP NAME AND SIGNATURE	STRUCTURAL ENG'S NAME AND SIGNATURE	BUILDER NAME AND SIGNATURE	DIGITAL SIGNATURE
MD SHOAB ALAM JNP/ENG/001/2017			