

Project Title :
PROPOSED BUILDING PLAN FOR:- HASAN IMAM. S/O - MOHAMMAD HASIM . MAUZA-ASNA .WARD NO- 07 . P.S-TELAIYA. P.S NO- 235 .
KHATA NO- 21 .PLOT NO- 2219 . DISTT-KODERMA (JHARAKHAND)

PROPOSED BUILDING PLAN FOR:- HASAN IMAM. S/O - MOHAMMAD HASIM . MAUZA-ASNA .WARD NO- 07 . P.S-TELAIYA. P.S NO- 235 .
KHATA NO- 21 .PLOT NO- 2219 . DISTT-KODERMA (JHARAKHAND)

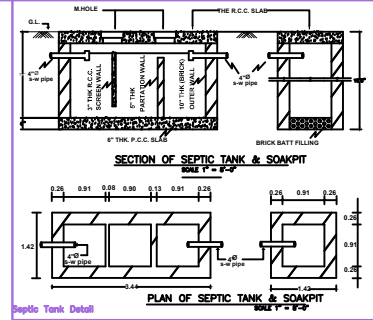

NORTH - 30M WIDE RANCHI PATNA ROAD
SOUTH - SHEIKH TEJU
EAST - SHEIKH TEJU
WEST - SMT MADHURI DEVI

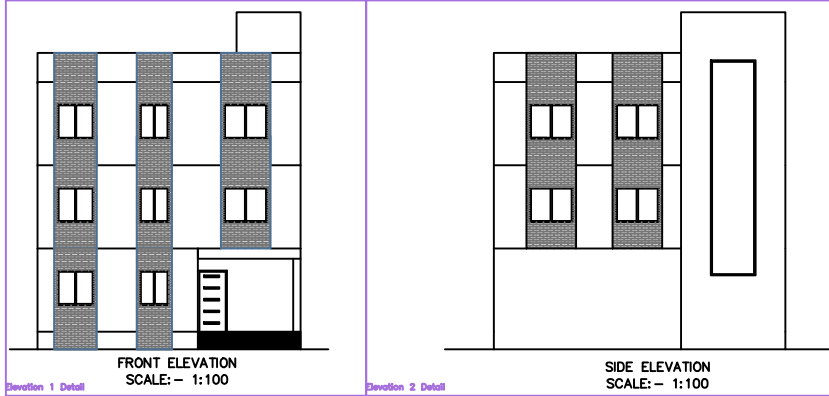
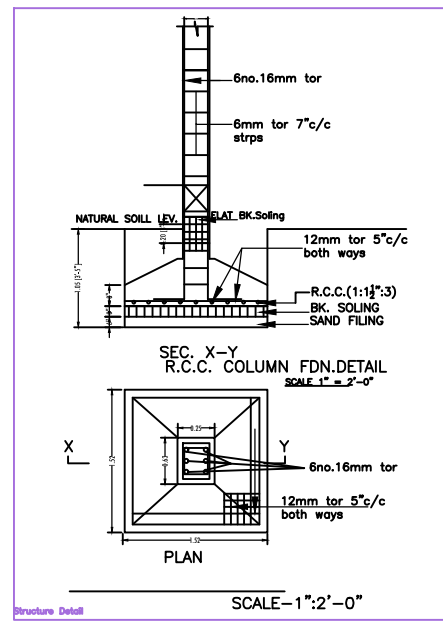
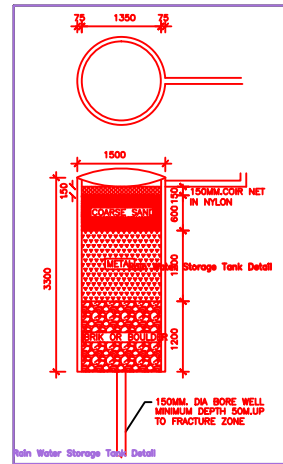
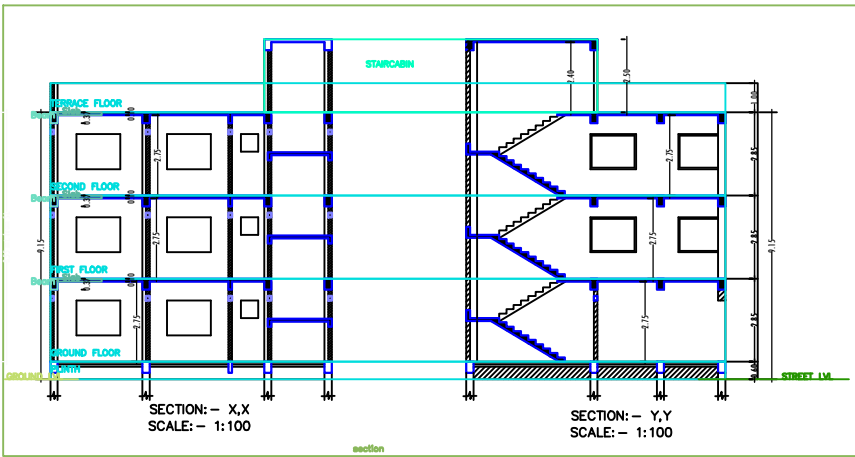
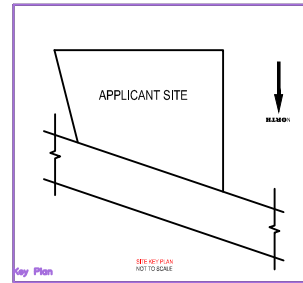

NORTH

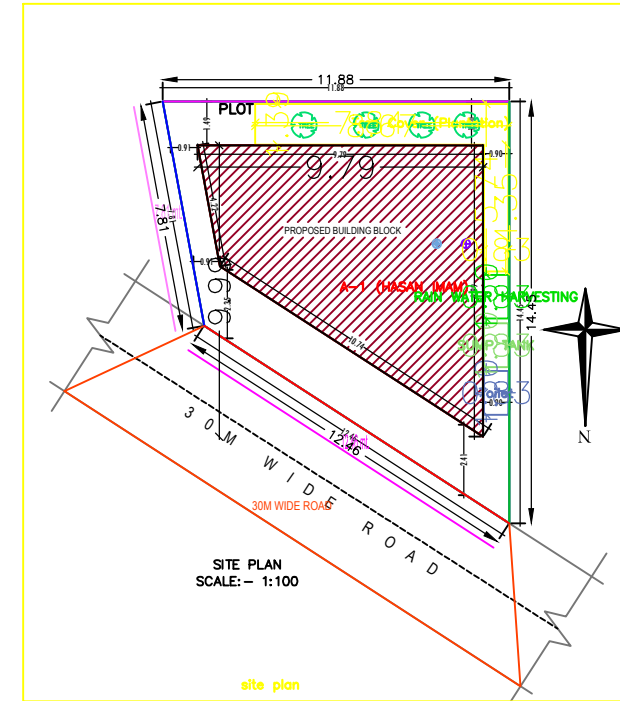

AREA STATEMENT - JHARRI LAIYA NAGAR	
PARISHAD	VERSION NO. 1.0.20
PROJECT DETAIL	VERSION DATE: 16/10/2020
Threat No. :-	Plot Use - Residential
Region :- BHARHAND URBAN LOCAL BODIES	Plot Category - Banglow Dwelling / Non Apartment
District - KODERMA	Land Use Zone - NA
Application Type - General Proposal	Abutting Road Width :-
Project Type - Building Permission	Plot No. :-
Location - 152 Area	Thana No. :-
Sub Location - NA	Holding No. :-
Village/Mauza Name :-	Khata No. :-
Ward No. :-	North :-
Road/Street :-	South :-
	East :-
	West :-
AREA DETAILS:	
AREA OF PLOT (Sq.mtr)	(A)
Plot Area (Gross Plot Area)	(A-Deductions)
Deductions for Gross Plot Area	
COF Area	
Deductions for Balance Plot Area (from Gross Plot Area)	
COF Area	
Balance Plot Area (Net Plot Area - Recreational/Amenity space)	(A-Deductions)
Plot Area for Coverage (Net Plot Area)	(A-Deductions)
Plot Area for FSI (Net Plot Area - Road/Walkway Area)	(A-Deductions)
Accessory/Use Area	
COVERAGE CHECK	
Proposed Coverage Area (53.91 %)	65.34
Total Coverage Area (53.91 %)	65.34
FAR CHECK	
Proposed Area of FAR	180.71
Total Area of FAR	180.71
BUILT UP AREA CHECK	
Total Proposed Built Up Area	196.01
ARCH / ENG / SUPERVISOR (Regd)	OWNER
DEVELOPMENT AUTHORITY	
	LOCAL BODY

COLOR INDEX	
Plot Boundary	Green
Abutting Road	Red
Proposed Work (Coverage Area)	Blue
Existing (to be retained)	Yellow
Existing (to be demolished)	Black

PARKING CALCULATION:		
Parking Type	Prop No.	Prop Area
Other Parking	1	15.30
Total Area	1	15.30

MARGIN DETAIL:					
Building / Wing Name	Road Name	Front Margin	Rear Margin	Side 1 Margin	Side 2 Margin
P.T. HASAN IMAM	30M WIDE ROAD	2.00	1.50	0.90	0.90

FAR & Tenement Details (Table 4c-1)						
Building	No. of Same Bldg	Total Built Up Area (Sq.mt)	Deductions (Area in Sq.mt)	Proposed FAR Area (Sq.mt)	Total FAR Area (Sq.mt)	Tenent (No.)
A (HASAN IMAM)	1	196.01	15.30	180.71	180.71	01
Grand Total	1	196.01	15.30	180.71	180.71	01

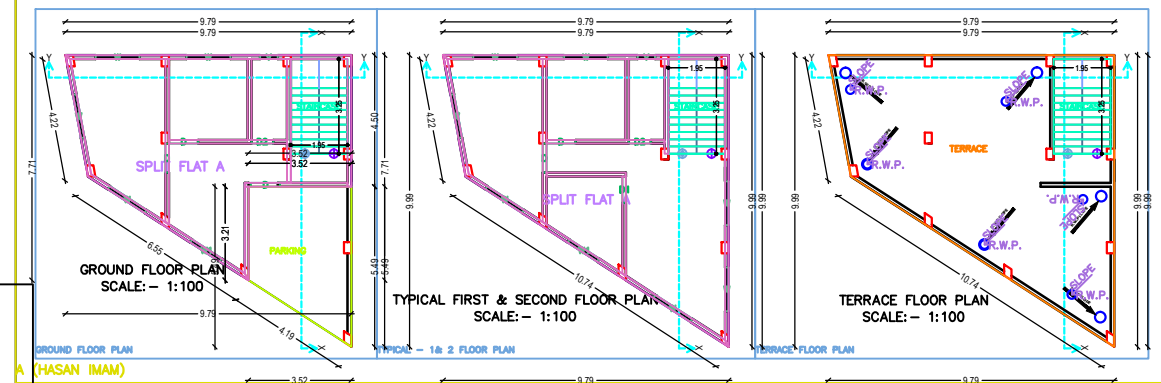

Building -A (HASAN IMAM)						
Floor Name	Area (Sq.mt)	Deductions (Area in Sq.mt)	Proposed FAR Area (Sq.mt)	Total FAR Area (Sq.mt)	Tenent (No.)	
Ground Floor	65.33	15.30	50.03	50.03	01	
First Floor	65.34	0.00	65.34	65.34	00	
Second Floor	65.34	0.00	65.34	65.34	00	
Terrace Floor	0.00	0.00	0.00	0.00	00	
Total	196.01	15.30	180.71	180.71	01	
Total Number of Same Buildings	1					
Total	196.01	15.30	180.71	180.71	01	

SCHEDULE OF JOINERY:				
BUILDING NAME	NAME	LENGTH	HEIGHT	NOS
A (HASAN IMAM)	D2	0.75	2.13	03
A (HASAN IMAM)	D1	0.90	2.13	02
A (HASAN IMAM)	D	1.00	2.13	07
Total				12

SCHEDULE OF JOINERY:				
BUILDING NAME	NAME	LENGTH	HEIGHT	NOS
A (HASAN IMAM)	V	0.60	1.50	03
A (HASAN IMAM)	WH	1.20	1.20	03
A (HASAN IMAM)	W	1.50	1.20	18
Total				24

UnitBUA Table for Building -A (HASAN IMAM)						
FLOOR	Name	UnitBUA Type	UnitBUA Area	Carpet Area	No. of Rooms	No. of Tenement
GROUND FLOOR PLAN	SPLIT FLAT A	FLAT	92.60	87.78	4	1
Total			92.60	87.78	14	1