

SITE PLAN

SITE PLAN

FAR & Tenement Details (Table 4c-1)

Building	No. of Same Bldg	Total Built Up Area (Sq.mt.)	Proposed FAR Area (Sq.mt.) Resi.	Total FAR Area (Sq.mt.)	Total Consumed Additional FAR Area (Sq.mt.)	Tnmt (No.)
AA (AA)	1	98.64	98.64	98.64	98.64	01
<b>Grand Total :</b>	<b>1</b>	<b>98.64</b>	<b>98.64</b>	<b>98.64</b>	<b>98.64</b>	<b>01</b>

Proposal Basic Information

Proposal File No.	JNP/IBP/0110W23/2021
Owner Name	SMT. JYOTI KUMARI
Khata No	102
Plot No	5909/6328
Village Name	Gomo
Use	Residential
SubUse	Bungalow/ Dwelling / Non Apartment

AREA STATEMENT	VERSION NO. : 1.0.61
JHUMRITILAIYA NAGAR PARISHAD	VERSION DATE: 16/10/2020
PROJECT DETAIL:	
Region: JHARKHAND URBAN LOCAL BODIES	Plot Use: Residential
District: KODERMA	Plot SubUse: Bungalow/ Dwelling / Non Apartment
Authority: JHUMRITILAIYA NAGAR PARISHAD	PlotNearbyReligiousStructure: NA
Inward No: JNP/IBP/0110W23/2021	Plot/SubPlot No: 5909/6328
Application Type: General Proposal	North: Road Width - 3.05MTR WIDE ROAD
Project Type: Building Permission	South: Plot No. - LAND OF SRI RAJESH PRASAD
Nature of Development: New	East: Plot No. - 3.66 Mtr. WIDE ROAD
Location of Development Area: Old Area	West: Plot No. - LAND OF SMT. RINKU KUMARI
AREA DETAILS:	
AREA OF PLOT (Minimum)	(A) 80.88
NET AREA OF PLOT(Gross Plot Area - Deduction from Gross Plot area)	(A-Deductions) 80.88
Deduction for Balance Plot Area(from Gross Plot Area)	
Common Plot	17.96
Total	17.96
BALANCE AREA OF PLOT(Net Plot Area - Recreational/Amenity space)	(A-Deductions) 62.92
PLOT AREA FOR COVERAGE(Net Plot Area)	(A-Deductions) 80.88
Plot Area for FAR (Net Plot Area + RoadWidening Area)	(A-Deductions) 80.88
COVERAGE CHECK	
Permissible Coverage area ( 70.00 % )	56.62
Proposed Coverage Area ( 60.98 % )	49.32
Total Prop. Coverage Area ( 60.98 % )	49.32
Balance coverage area ( 9.03 % )	7.30
FAR CHECK	
Perm. FAR Area ( 1.50 )	121.32
Total Perm. FAR area	121.32
Residential FAR	98.63
Proposed FAR Area	98.63
Total Proposed FAR Area	98.63
Consumed FAR (Factor)	1.22
Balance FAR Area	22.69
BUILT UP AREA CHECK	
Total Proposed BuiltUp Area	98.64
ARCHITECT (Regd)	UPENDRA
ENGINEER (Regd)	
SUPERVISOR (Regd)	
OWNER (Regd)	SMT. JYOTI KUMARI
DEVELOPMENT AUTHORITY LOCAL BODY	

COLOR INDEX	
PLOT BOUNDARY	Black
ABUTTING ROAD	Green
PROPOSED CONSTRUCTION	Red
COMMON PLOT	Yellow
ROAD WIDENING AREA	Orange
EXISTING (To be retained)	Blue
EXISTING (To be demolished)	Light Yellow

Buildingwise Floor FAR Details

Floor Name	Building Name AA (AA)		Total	
	Proposed Built Up Area (Sq.mt.)	Proposed FAR Area (Sq.mt.)	Total Proposed Built Up Area (Sq.mt.)	Total FAR Area (Sq.mt.)
Ground Floor	49.32	49.32	49.32	49.32
First Floor	49.32	49.32	49.32	49.32
Terrace Floor	0.00	0.00	0.00	0.00
<b>Total :</b>	<b>98.64</b>	<b>98.64</b>	<b>98.64</b>	<b>98.64</b>

Building USE/SUBUSE Details

Building Name	Building Use	Building SubUse	Building Structure
AA (AA)	Residential	Residential Bldg/Apartment	Non-Highrise

LTP NAME AND SIGNATURE	STRUCTURAL ENG'S NAME AND SIGNATURE	BUILDER NAME AND SIGNATURE	DIGITAL SIGNATURE
UPENDRA JNP/ENG/0012/2017			

Proposal Basic Information

Proposal File No.	JNP/BP/0110/W23/2021
Owner Name	SMT. JYOTI KUMARI
Khata No	102
Plot No	5909/6328
Village Name	Gomo
Use	Residential
SubUse	Bungalow/ Dwelling / Non Apartment

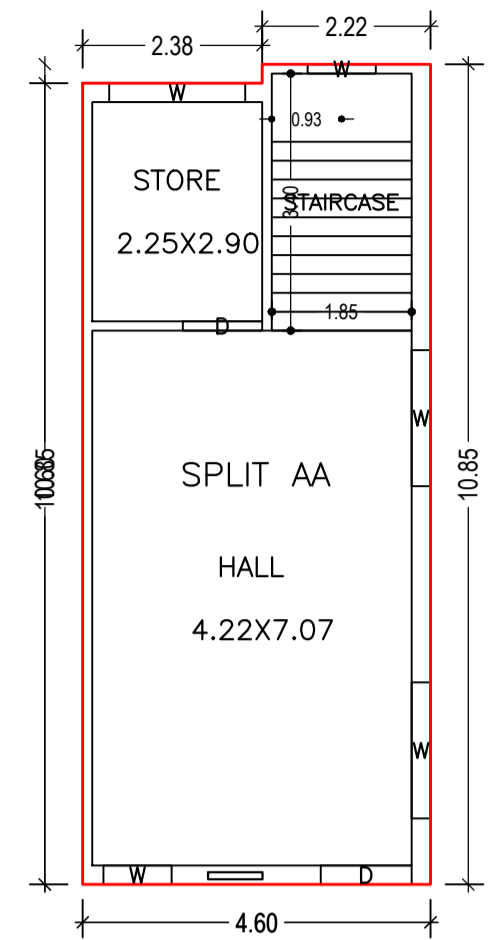

GROUND FLOOR PLAN (Proposed) (SCALE 1:100)

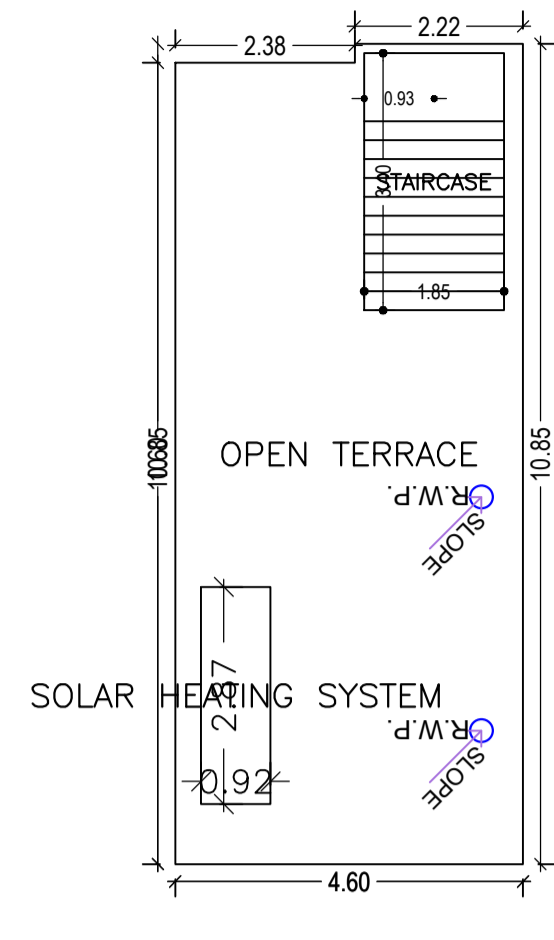

TERRACE FLOOR PLAN (SCALE 1:100)

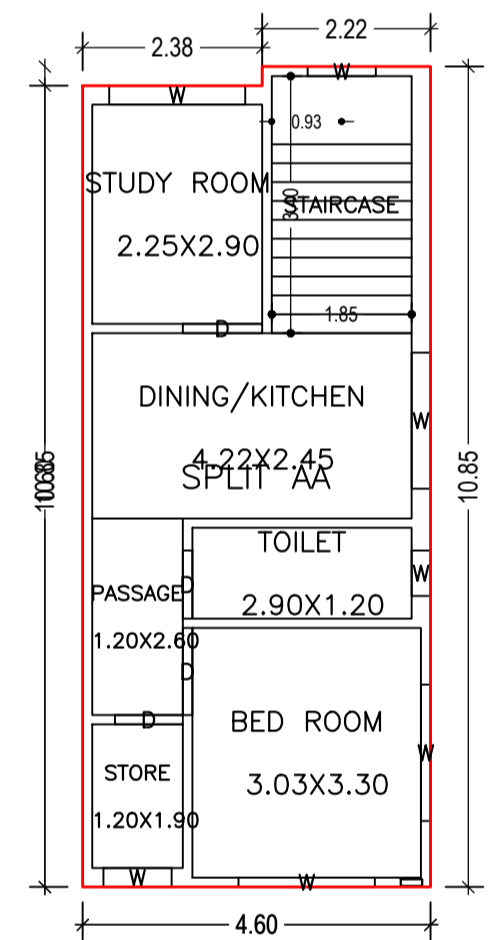

FIRST FLOOR PLAN (Proposed) (SCALE 1:100)

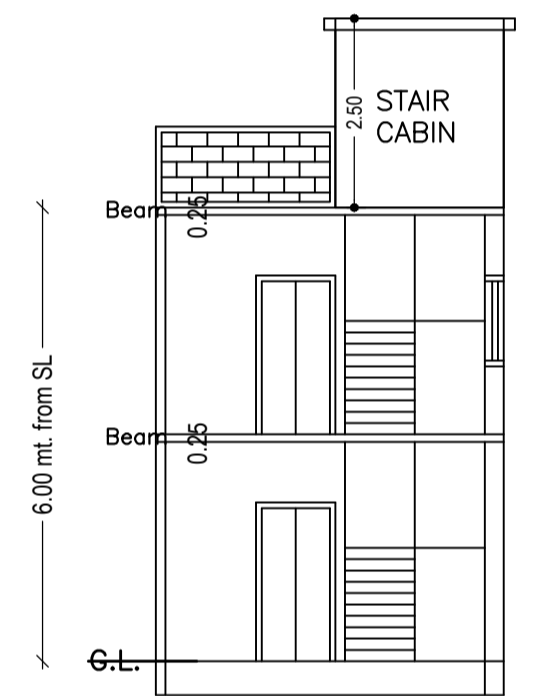

SECTION ON X-X

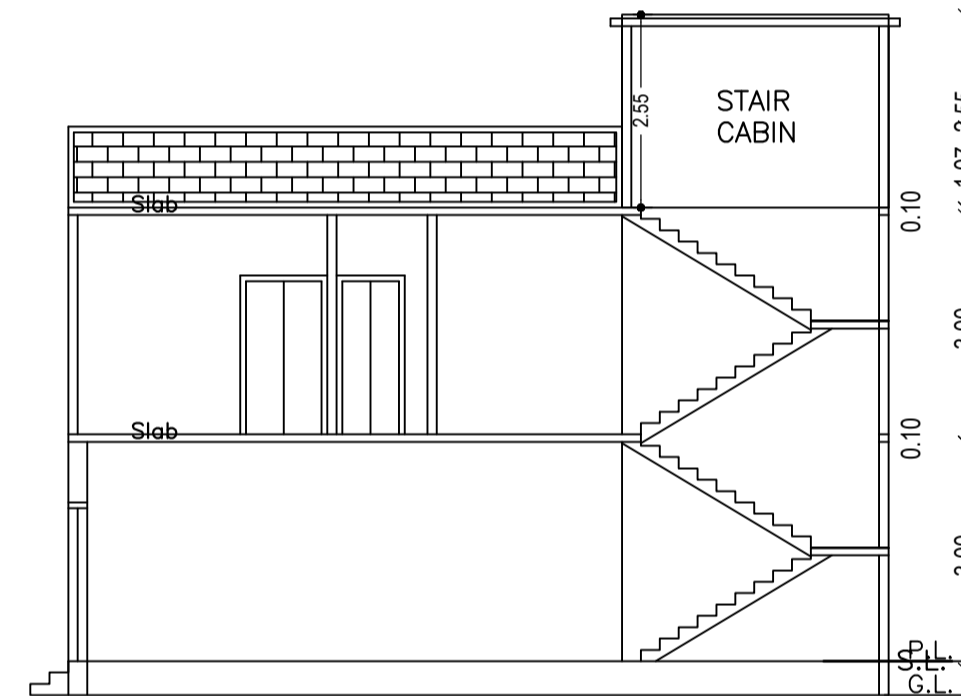

SECTION ON Y-Y

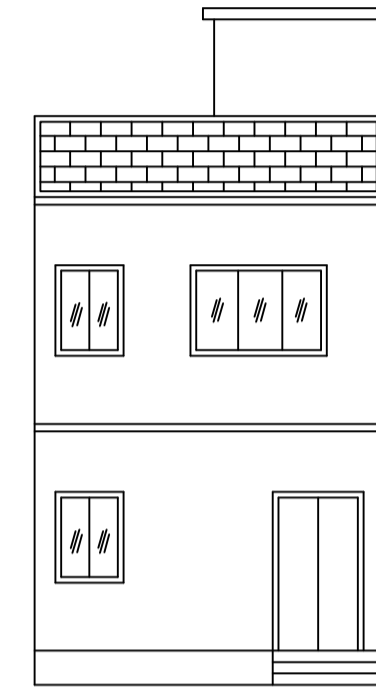

FRONT ELEVATION

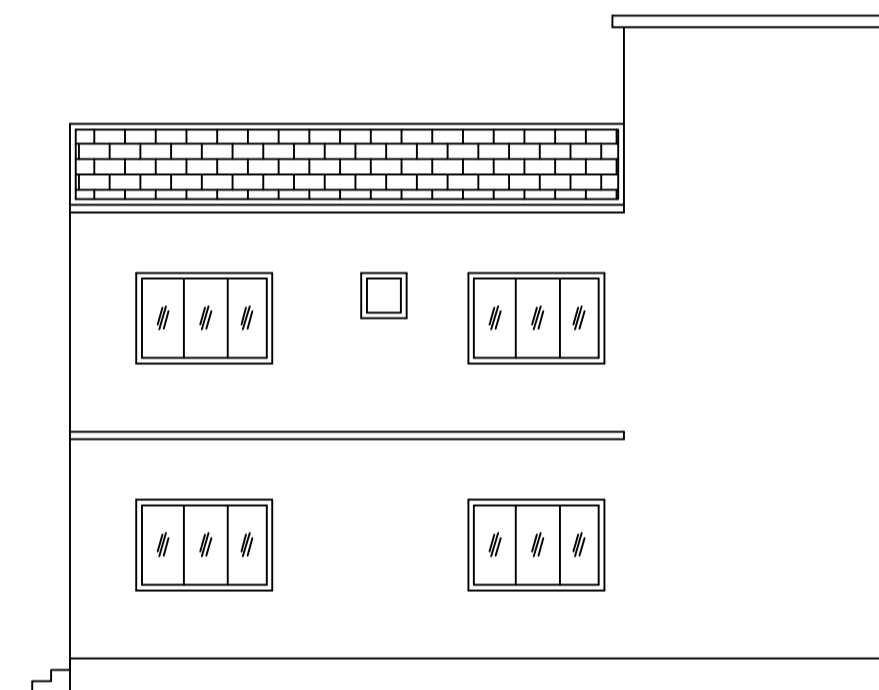

RIGHT SIDE ELEVATION

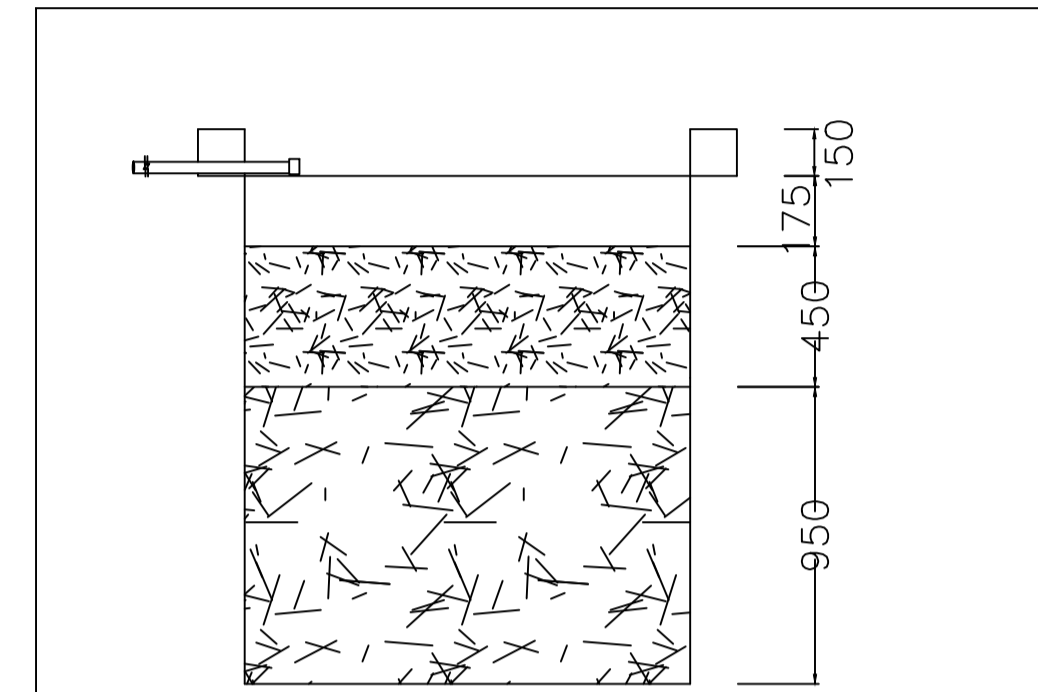

SECTION AT Y-Y

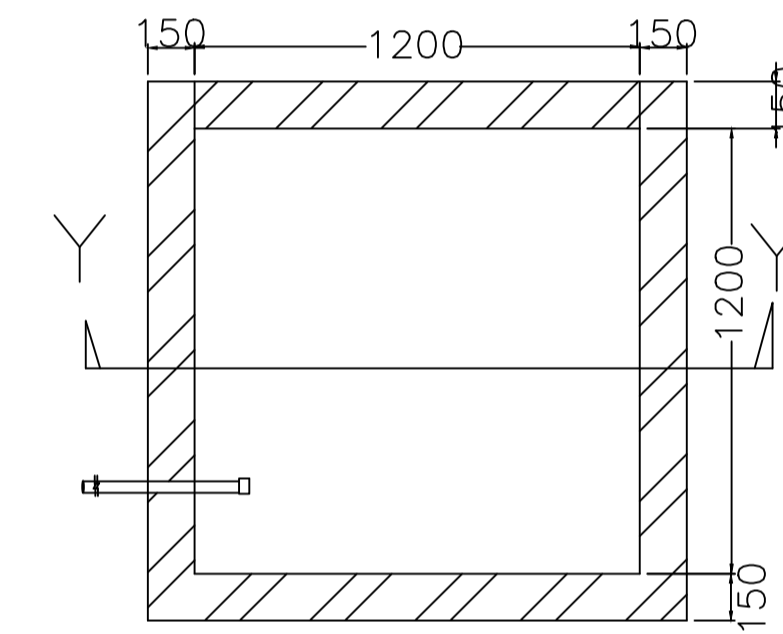

PLAN OF RECHARGE WELL

WATER HARVESTING

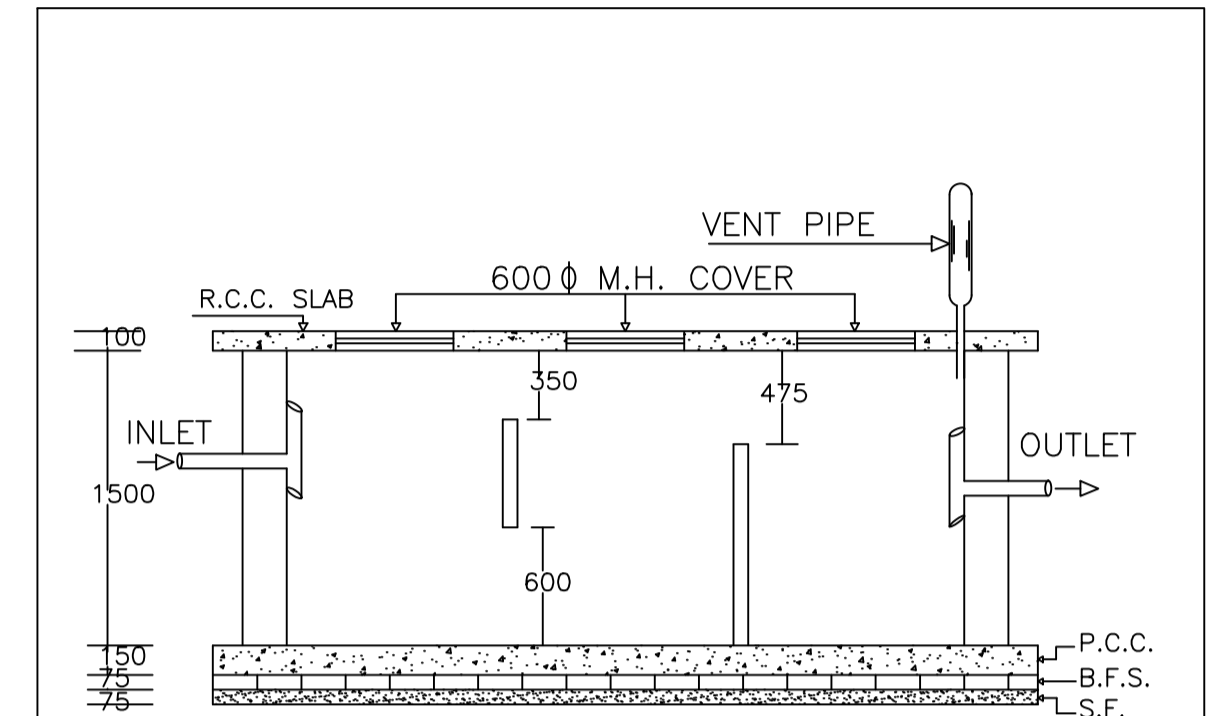

PLAN OF SEPTIC TANK

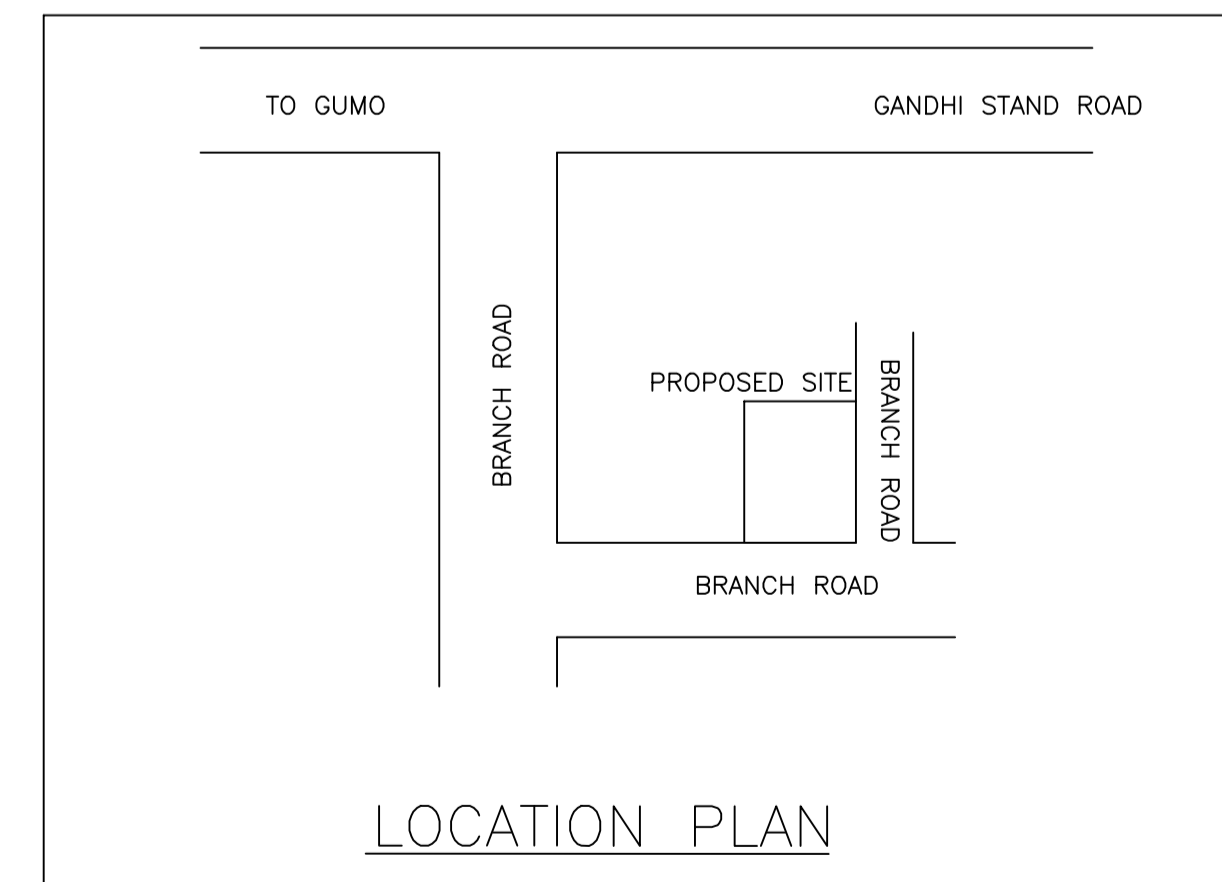

LOCATION PLAN

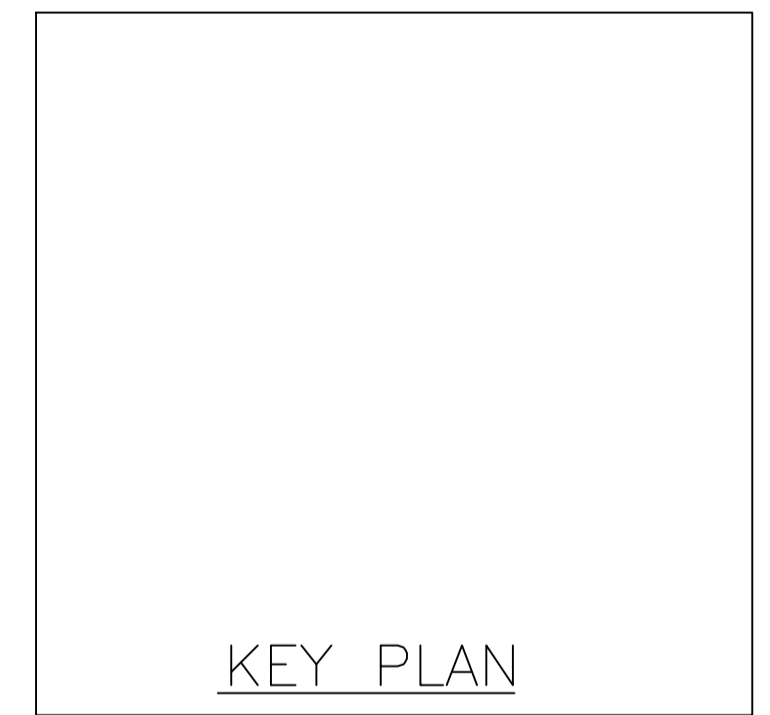

KEY PLAN

Building :AA (AA)

Floor Name	Total Built Up Area (Sq.mt.)	Proposed FAR Area (Sq.mt.) Resi.	Total FAR Area (Sq.mt.)	Total Consumed Additional FAR Area (Sq.mt.)	Tnmt (No.)
Ground Floor	49.32	49.32	49.32	49.32	01
First Floor	49.32	49.32	49.32	49.32	00
Terrace Floor	0.00	0.00	0.00	0.00	00
Total:	98.64	98.64	98.64	98.64	01
Total Number of Same Buildings	1				
Total:	98.64	98.64	98.64	98.64	01

SCHEDULE OF DOOR:

BUILDING NAME	NAME	LENGTH	HEIGHT	NOS
AA (AA)	D	0.90	2.10	02
AA (AA)	D	1.05	2.10	02
AA (AA)	D	1.15	2.10	01
AA (AA)	D	1.20	2.10	01

SCHEDULE OF WINDOW/VENTILATION:

BUILDING NAME	NAME	LENGTH	HEIGHT	NOS
AA (AA)	W	0.60	1.20	01
AA (AA)	W	0.90	1.20	04
AA (AA)	W	1.80	1.20	07

UnitBUA Table for Building :AA (AA)

FLOOR	Name	UnitBUA Type	UnitBUA Area	Carpet Area	No. of Rooms	No. of Tenement
GROUND FLOOR PLAN	SPLIT AA	FLAT	98.63	98.54	2	1
FIRST FLOOR PLAN	SPLIT AA	FLAT	0.00	0.00	6	0
Total:	-	-	98.63	98.54	8	1

LTP NAME AND SIGNATURE	STRUCTURAL ENG'S NAME AND SIGNATURE	BUILDER NAME AND SIGNATURE	DIGITAL SIGNATURE
UPENDRA JNP/ENG/0012/2017			

## Proposal Basic Information

Proposal File No.	JNP/IBP/0110/W23/2021
Owner Name	SMT. JYOTI KUMARI
Khata No	102
Plot No	5909/6328
Village Name	Gomo
Use	Residential
SubUse	Bungalow/ Dwelling / Non Apartment

BRIEF SPECIFICATION

FOUNDATION-----CEMENT CONCRETE (1:1.5:3)  
 BRICK WORK IN FOUNDATION & SUPERSTRUCTURE  
 FIRST CLASS BRICK WORK IN CEMENT MORTAR (1:6)  
 D.P.C.-----25 D.P.C. IN CEMENT CONCRETE (1:2:4)  
 FLOOR-----25 I.P.S. OVER 75 P.C.C.  
 ROOF-----100 THK. R.C.C. ROOF (1:1.5:3)  
 LINTEL-----150 THK. R.C.C. LINTEL (1:1.5:3)  
 STAIRS-----RISE-- 150, TREAD-- 250

DETAILS OF AREA

TOTAL AREA (AS PER DEED) -----80.97 SQM.  
 TOTAL AREA (AS PER SITE) -----80.88 SQM.  
 GROUND FLOOR AREA-----49.32 SQM.--  
 FIRST FLOOR AREA-----49.32 SQM.-----  
 TOTAL COVERED AREA-----98.64 SQM.--  
 % PLINTH AREA-----60.98 %-----  
 FAR -----1.22-----

SCHEDULE

D	=	1.200X2.100	=	1.800X1.200
D1	=	1.050X2.100	=	0.900X1.200
D2	=	0.900X2.100	=	0.600X0.600

TITLE OF DRAWING

PLAN OF PROPOSED RESIDENTIAL  
 BUILDING OF SMT JYOTI KUMARI W/O SRI RAVI  
 RANJAN ,  
 WARD NO.- 23, UNDER MOUZA - GUMO, NO.-  
 12,  
 KHATA NO.- 102, PLOT NO.- 5909 / 6328 (P)  
 IN THE DISTT. OF KODERMA (JHARKHAND).

SIGNATURE OF OWNER

SIGNATURE OF ENGINEER

SCALE

ALL DIMENSION ARE IN METRE

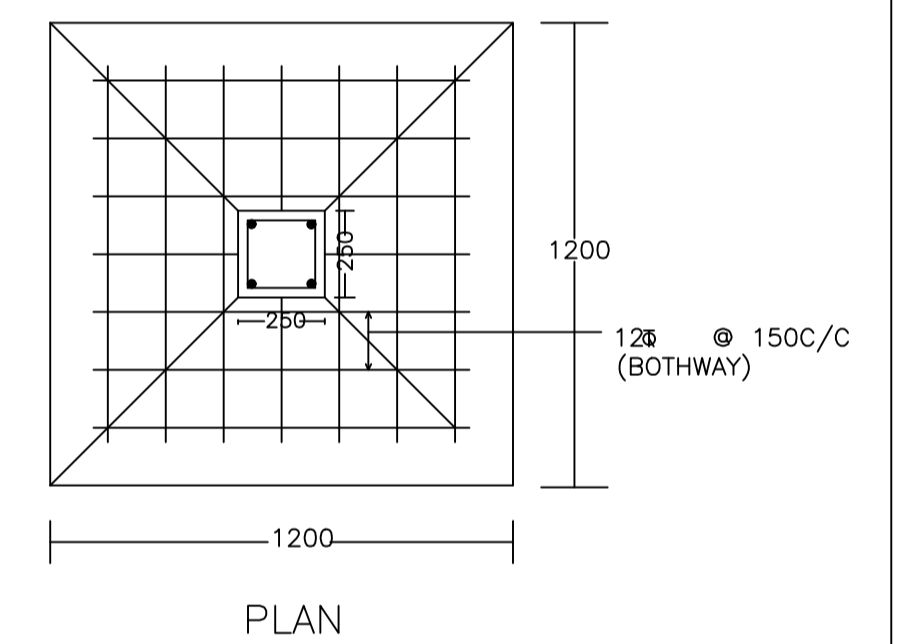
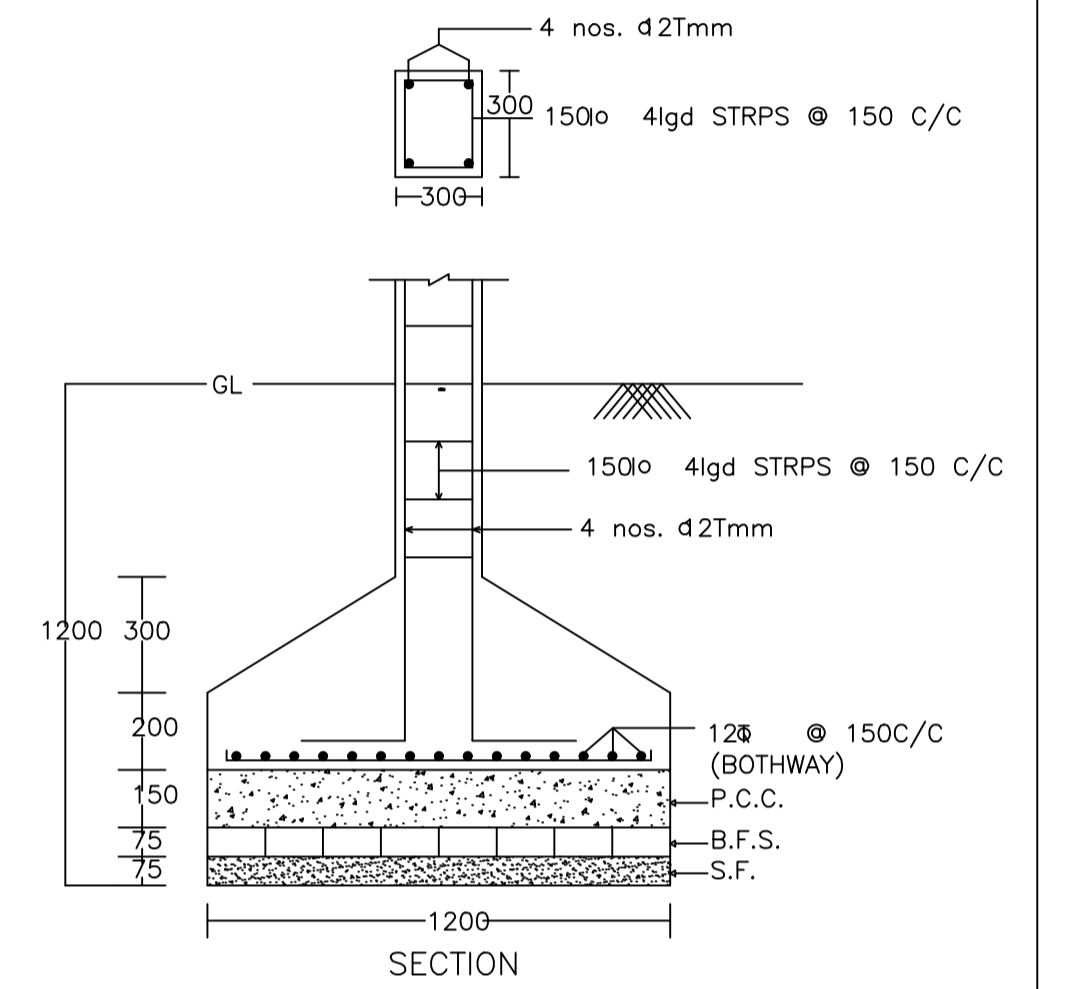
DETAIL OF COLUMNS

LTP NAME AND SIGNATURE	STRUCTURAL ENG'S NAME AND SIGNATURE	BUILDER NAME AND SIGNATURE	DIGITAL SIGNATURE
UPENDRA JNP/ENG/0012/2017			