

SITE PLAN

SMT. URMILA DEVI SITE PLAN

FAR & Tenement Details (Table 4c-1)

Building	No. of Same Bldg	Total Built Up Area (Sq.mt.)	Proposed FAR Area (Sq.mt.) Resi.	Total FAR Area (Sq.mt.)	Total Consumed Additional FAR Area (Sq.mt.)	Tnmt (No.)
A (URMILA DEVI)	1	165.63	165.63	165.63	165.63	01
Grand Total :	1	165.63	165.63	165.63	165.63	01

Proposal Basic Information

Proposal File No.	JNP/IBP/0026/W12/2021
Owner Name	URMILA DEVI
Khata No	284
Plot No	7320
Village Name	Tilaiya
Use	Residential
SubUse	Bungalow/ Dwelling / Non Apartment

AREA STATEMENT	VERSION NO. : 1.0.57
JHUMRITILAIYA NAGAR PARISHAD	VERSION DATE: 16/10/2020
PROJECT DETAIL:	
Region: JHARKHAND URBAN LOCAL BODIES	Plot Use: Residential
District: KODERMA	Plot SubUse: Bungalow/ Dwelling / Non Apartment
Authority: JHUMRITILAIYA NAGAR PARISHAD	PlotNearbyReligiousStructure: NA
Inward No: JNP/IBP/0026/W12/2021	PlotSubPlot No: 7320
Application Type: General Proposal	North: Plot No. - LAND OF SATNAM KAUR
Project Type: Building Permission	South: Plot No. - LAND OF NUNMAN MODI
Nature of Development: New	East: Road Width - 4.87
Location of Development Area: Old Area	West: Plot No. - LAND OF SRI GURUCHARAN SINGH
AREA DETAILS:	
AREA OF PLOT (Minimum)	(A) 92.06
NET AREA OF PLOT(Gross Plot Area - Deduction from Gross Plot area)	(A-Deductions) 92.06
Deduction for Balance Plot Area(from Gross Plot Area)	
Common Plot	13.24
Total	13.24
BALANCE AREA OF PLOT(Net Plot Area - Recreational/Amenity space)	(A-Deductions) 78.82
PLOT AREA FOR COVERAGE(Net Plot Area)	(A-Deductions) 92.06
Plot Area for FAR (Net Plot Area + Road Widening Area)	(A-Deductions) 92.06
COVERAGE CHECK	
Permissible Coverage area (70.00 %)	64.44
Proposed Coverage Area (59.97 %)	55.21
Total Prop. Coverage Area (59.97 %)	55.21
Balance coverage area (10.03 %)	9.23
FAR CHECK	
Perm. FAR Area (1.80)	165.71
Total Perm. FAR area	165.71
Residential FAR	165.63
Proposed FAR Area	165.63
Total Proposed FAR Area	165.63
Consumed FAR (Factor)	1.80
Balance FAR Area	0.08
BUILT UP AREA CHECK	
Total Proposed BuiltUp Area	165.63
ARCHITECT (Regd)	UPENDRA
ENGINEER (Regd)	
SUPERVISOR (Regd)	
OWNER (Regd)	URMILA DEVI
DEVELOPMENT AUTHORITY	LOCAL BODY

COLOR INDEX	
PLOT BOUNDARY	Black
ABUTTING ROAD	Green
PROPOSED CONSTRUCTION	Red
COMMON PLOT	Yellow
ROAD WIDENING AREA	Orange
EXISTING (To be retained)	Blue
EXISTING (To be demolished)	Light Blue

Buildingwise Floor FAR Details

Floor Name	Building Name A (URMILA DEVI)		Total	
	Proposed Built Up Area (Sq.mt.)	Proposed FAR Area (Sq.mt.)	Total Proposed Built Up Area (Sq.mt.)	Total FAR Area (Sq.mt.)
Ground Floor	55.21	55.21	55.21	55.21
First Floor	55.21	55.21	55.21	55.21
Second Floor	55.21	55.21	55.21	55.21
Terrace Floor	0.00	0.00	0.00	0.00
Total :	165.63	165.63	165.63	165.63

Building USE/SUBUSE Details

Building Name	Building Use	Building SubUse	Building Structure
A (URMILA DEVI)	Residential	Bungalow/ Dwelling / Non Apartment	Non-Highrise

LTP NAME AND SIGNATURE	STRUCTURAL ENG'S NAME AND SIGNATURE	BUILDER NAME AND SIGNATURE	DIGITAL SIGNATURE
UPENDRA JNP/ENG/0012/2017			

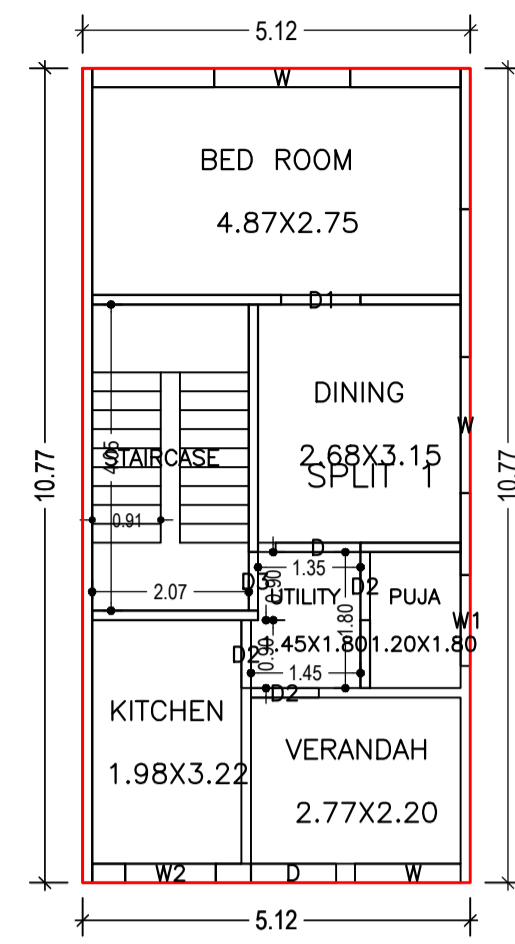

GROUND FLOOR PLAN (Proposed) (SCALE 1:100)

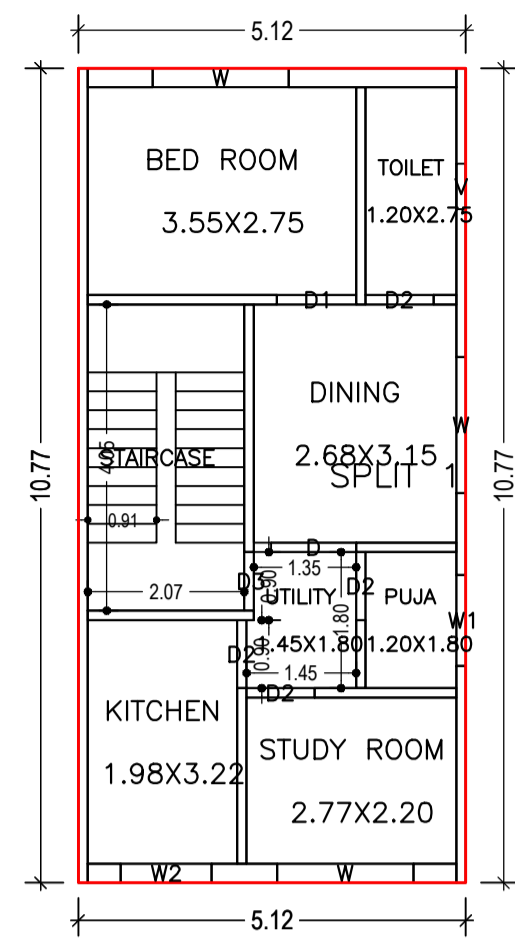

SECOND FLOOR PLAN (Proposed) (SCALE 1:100)

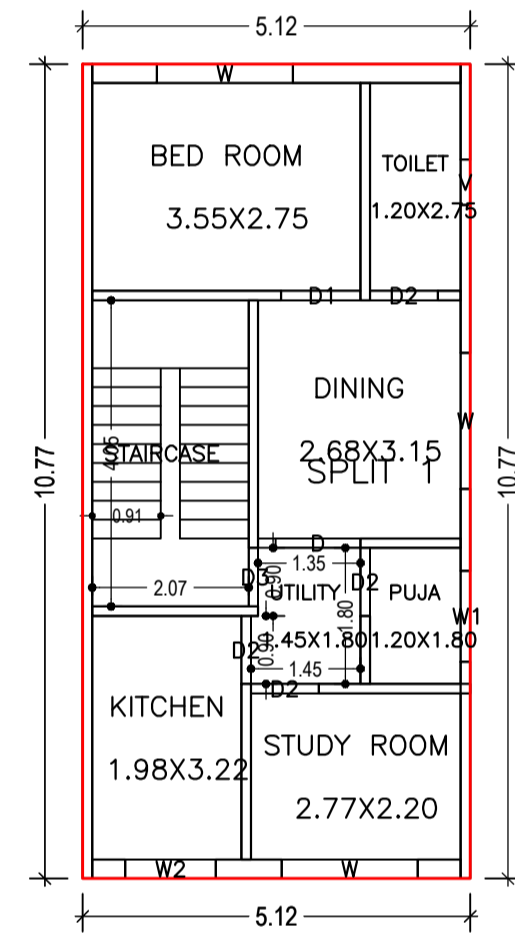

FIRST FLOOR PLAN (Proposed) (SCALE 1:100)

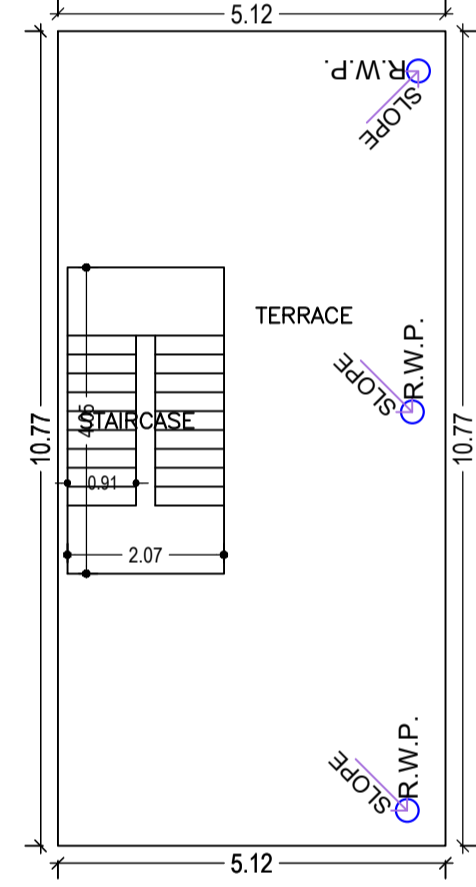

TERRACE FLOOR PLAN (SCALE 1:100)

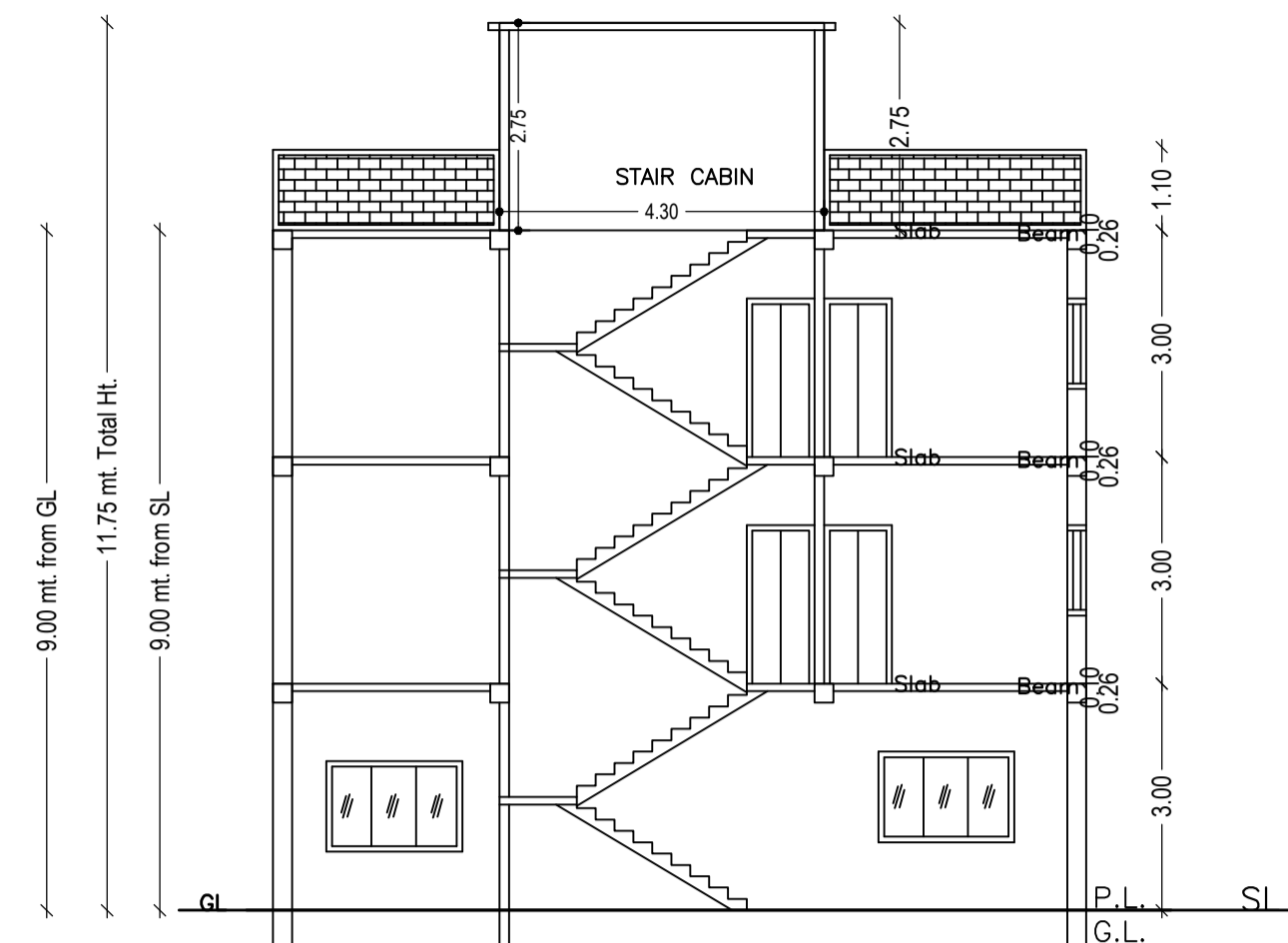

SECTION ON X-X

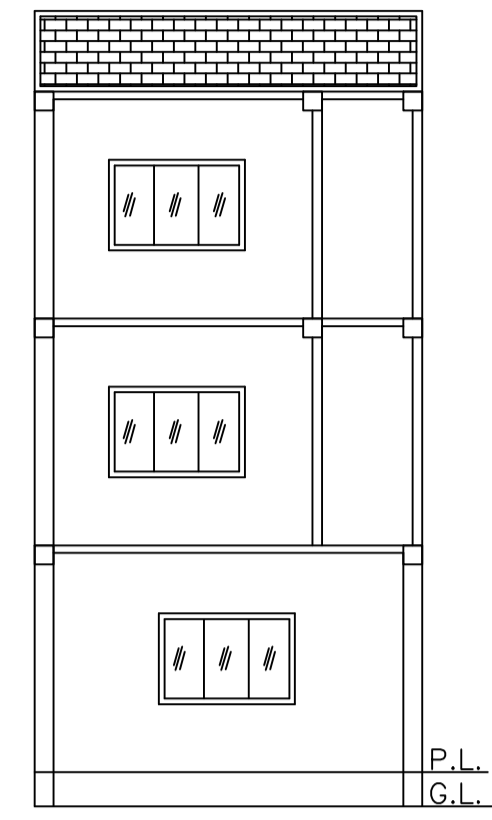

SECTION ON Y-Y

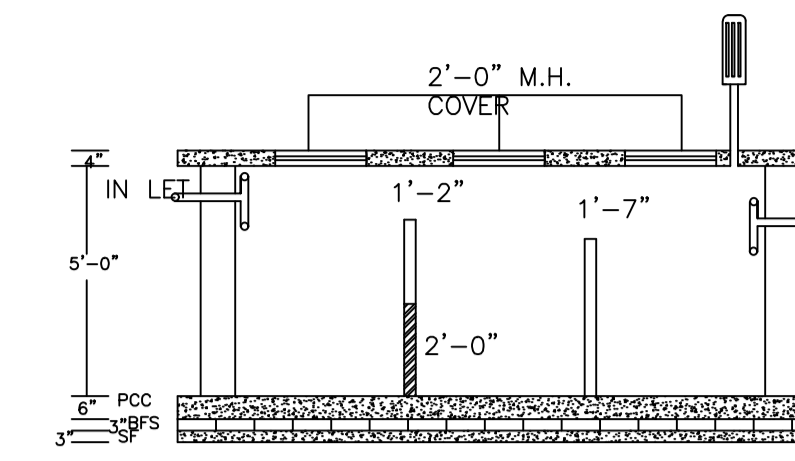

SECTION

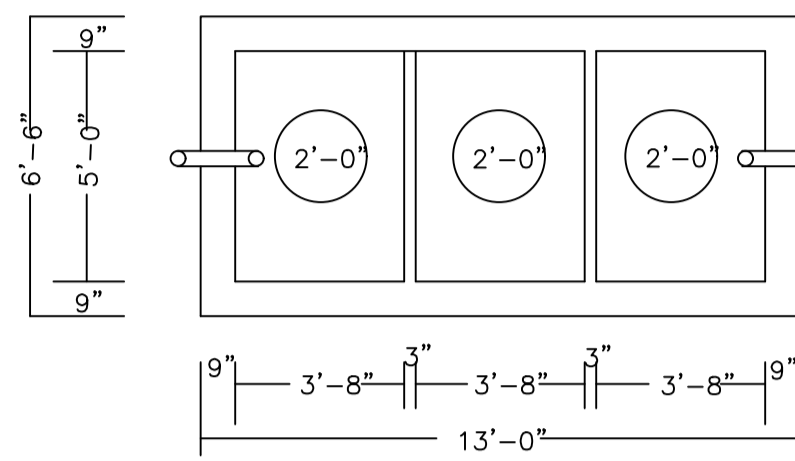

PLAN OF SEPTIC TANK (SCALE:-1/4"=1'-0")

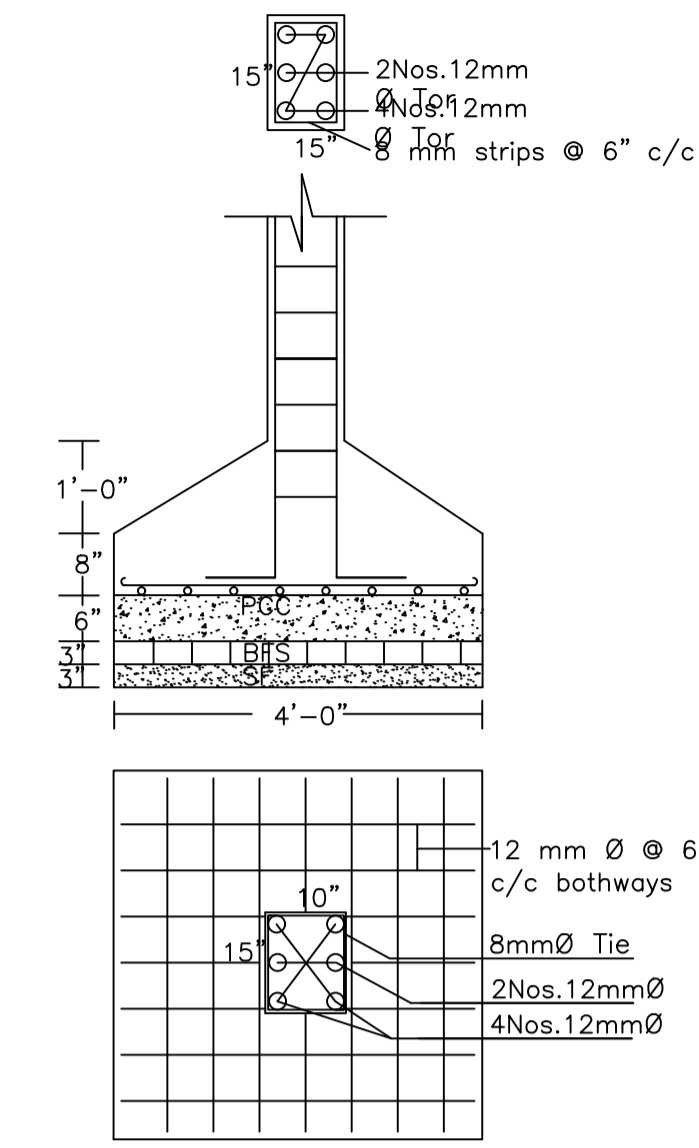

DETAILS OF COLUMNS

Proposal Basic Information	
Proposal File No.	JNP/IBP/0026/W12/2021
Owner Name	URMILA DEVI
Khata No	284
Plot No	7320
Village Name	Tilaiya
Use	Residential
SubUse	Bungalow/ Dwelling / Non Apartment

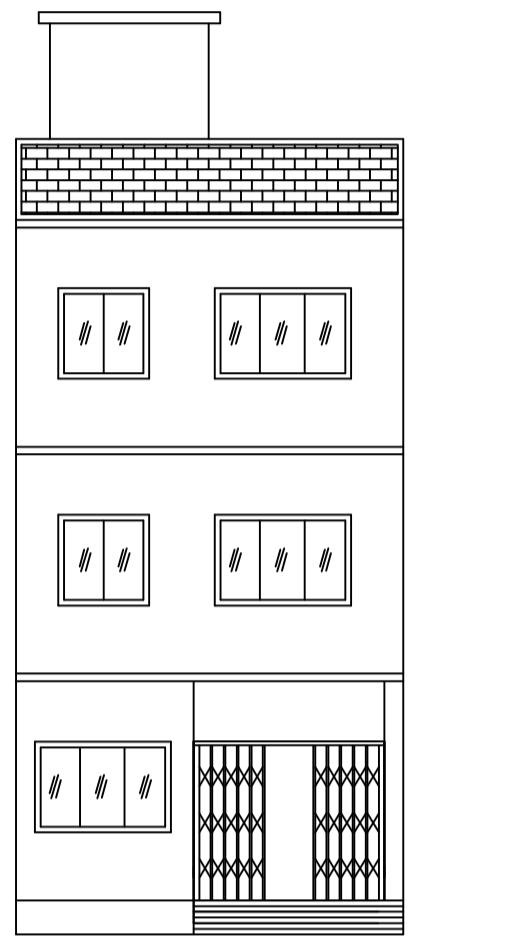

FRONT ELEVATION

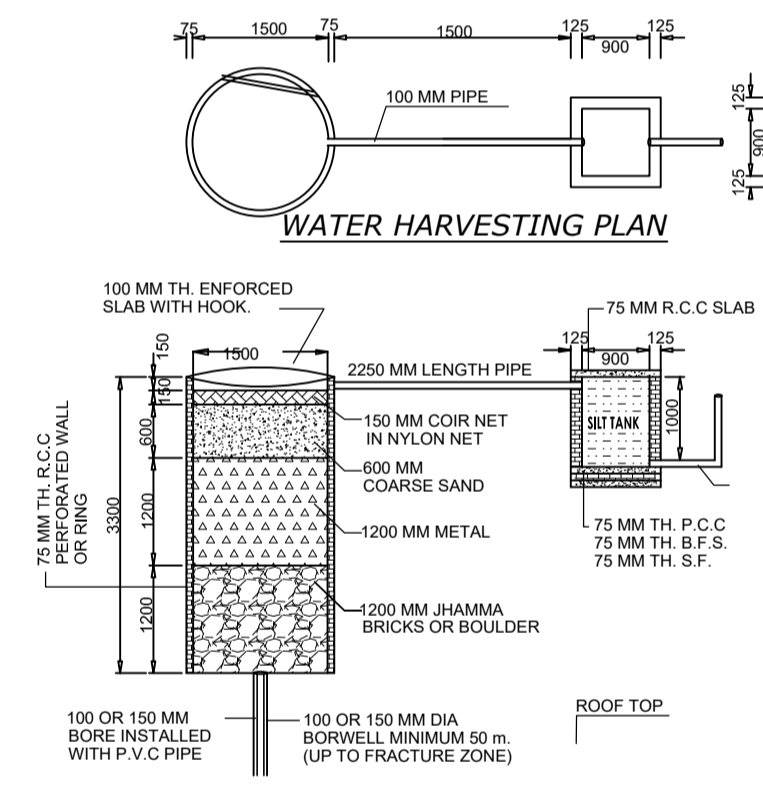

WATER HARVESTING PLAN

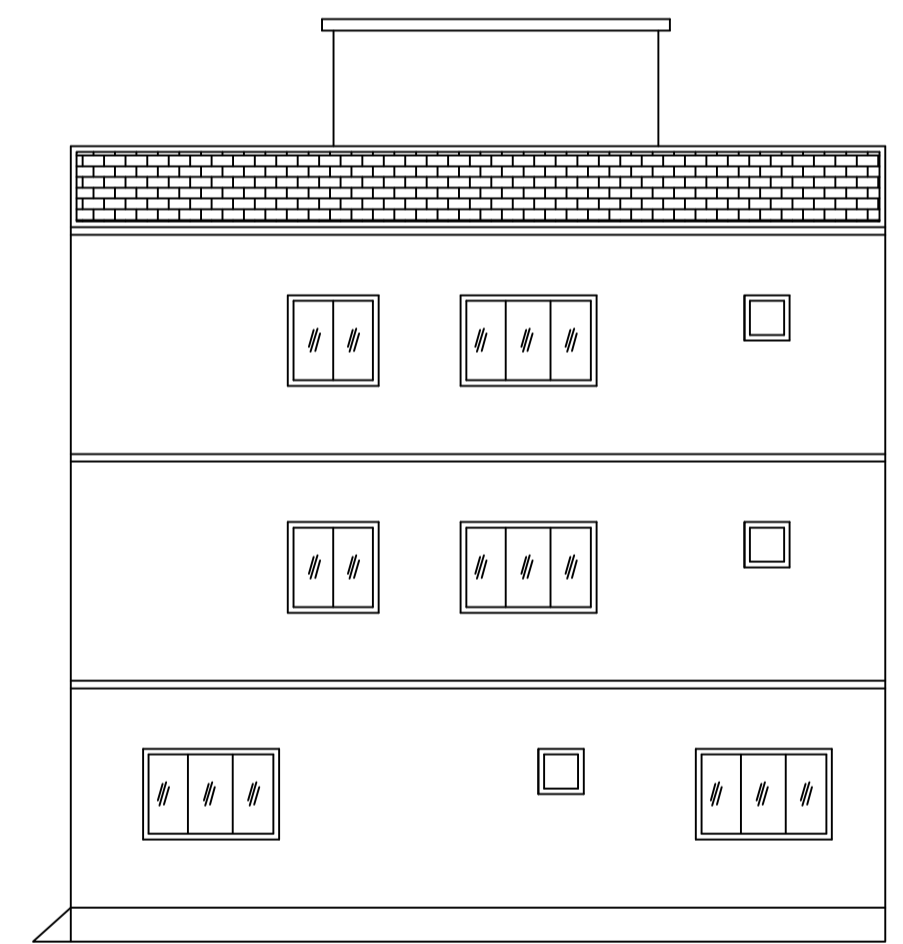
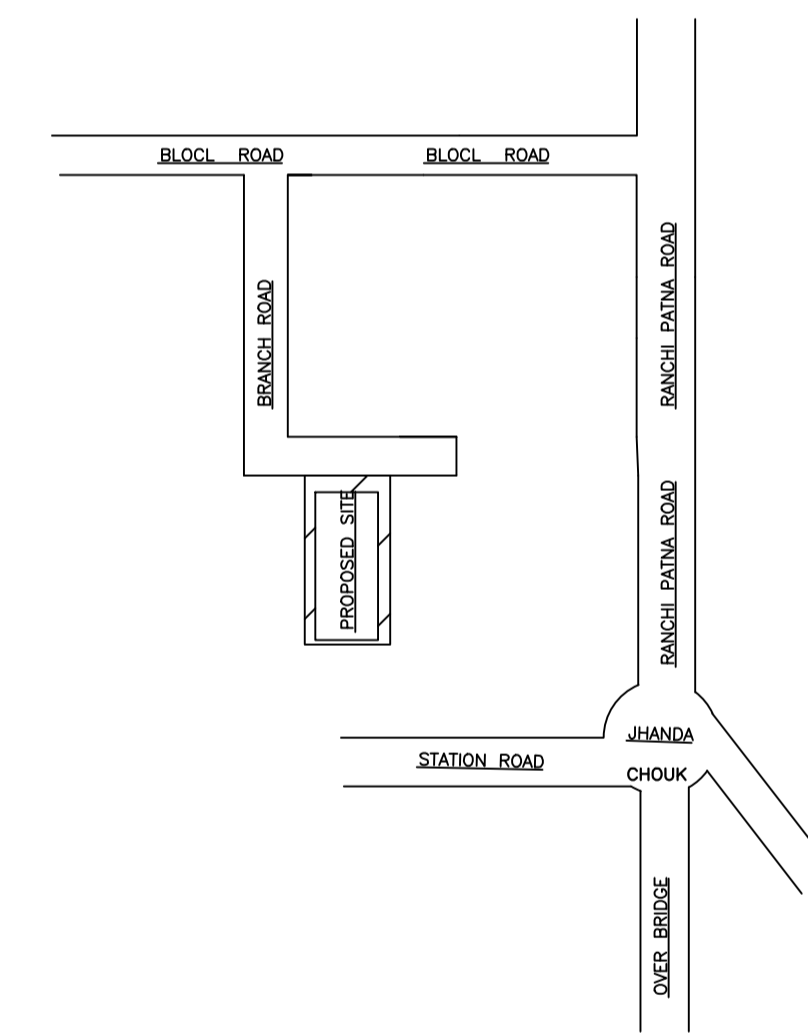

RIGHT SIDE ELEVATION

Building :A (URMILA DEVI)

Floor Name	Total Built Up Area (Sq.mt.)	Proposed FAR Area (Sq.mt.) Resi.	Total FAR Area (Sq.mt.)	Total Consumed Additional FAR Area (Sq.mt.)	Tnmt (No.)
Ground Floor	55.21	55.21	55.21	55.21	01
First Floor	55.21	55.21	55.21	55.21	00
Second Floor	55.21	55.21	55.21	55.21	00
Terrace Floor	0.00	0.00	0.00	0.00	00
Total:	165.63	165.63	165.63	165.63	01
Total Number of Same Buildings	1				
Total:	165.63	165.63	165.63	165.63	01

SCHEDULE OF DOOR:

BUILDING NAME	NAME	LENGTH	HEIGHT	NOS
A (URMILA DEVI)	D3	0.77	2.10	03
A (URMILA DEVI)	D2	0.90	2.10	11
A (URMILA DEVI)	D1	1.05	2.10	03
A (URMILA DEVI)	D	1.13	2.10	04

SCHEDULE OF WINDOW/VENTILATION:

BUILDING NAME	NAME	LENGTH	HEIGHT	NOS
A (URMILA DEVI)	V	0.60	1.20	02
A (URMILA DEVI)	W2	1.20	1.20	03
A (URMILA DEVI)	W1	1.20	1.20	03
A (URMILA DEVI)	W	1.40	1.20	01
A (URMILA DEVI)	W	1.80	1.20	08

UnitBUA Table for Building :A (URMILA DEVI)

FLOOR	Name	UnitBUA Type	UnitBUA Area	Carpet Area	No. of Rooms	No. of Tenement
GROUND FLOOR PLAN	SPLIT 1	FLAT	165.63	149.80	6	1
FIRST FLOOR PLAN	SPLIT 1	FLAT	0.00	0.00	7	0
SECOND FLOOR PLAN	SPLIT 1	FLAT	0.00	0.00	7	0
Total:	-	-	165.63	149.80	20	1

LTP NAME AND SIGNATURE	STRUCTURAL ENG'S NAME AND SIGNATURE	BUILDER NAME AND SIGNATURE	DIGITAL SIGNATURE
UPENDRA JNP/ENG/0012/2017			