

SMT. SUNITA DEVI SITE PLAN

FAR & Tenement Details (Table 4c-1)

Building	No. of Same Bldg	Total Built Up Area (Sq.mt.)	Proposed FAR Area (Sq.mt.) Resi.	Total FAR Area (Sq.mt.)	Total Consumed Additional FAR Area (Sq.mt.)	Tnmt (No.)
A (SUNITA DEVI HOUSE PLAN)	1	71.02	71.02	71.02	71.02	01
<b>Grand Total :</b>	<b>1</b>	<b>71.02</b>	<b>71.02</b>	<b>71.02</b>	<b>71.02</b>	<b>01</b>

Proposal Basic Information

Proposal File No.	JNP/BI/0018/W10/2021
Owner Name	SUNITA DEVI
Khata No	291
Plot No	7421/7939
Village Name	Tilaiya
Use	Residential
SubUse	Bungalow/ Dwelling / Non Apartment

AREA STATEMENT	VERSION NO. : 1.0.55
JHUMRITILAIYA NAGAR PARISHAD	VERSION DATE: 16/10/2020
PROJECT DETAIL:	
Region: JHARKHAND URBAN LOCAL BODIES	Plot Use: Residential
District: KODERMA	Plot SubUse: Bungalow/ Dwelling / Non Apartment
Authority: JHUMRITILAIYA NAGAR PARISHAD	PlotNearbyReligiousStructure: NA
Inward No: JNP/BI/0018/W10/2021	Plot/SubPlot No: 7421/7939
Application Type: General Proposal	North: Road Width - 3.65 Mtr. WIDE ROAD
Project Type: Building Permission	South: Plot No. - LAND OF LAKSHAN SINGH
Nature of Development: New	East: Plot No. - LAND OF VENDOR
Location of Development Area: Old Area	West: Plot No. - LAND OF PUNAM DEVI
AREA DETAILS:	
AREA OF PLOT (Minimum)	(A) 64.48
NET AREA OF PLOT(Gross Plot Area - Deduction from Gross Plot area)	(A-Deductions) 64.48
Deduction for Balance Plot Area(from Gross Plot Area)	
Common Plot	12.04
BALANCE AREA OF PLOT(Net Plot Area - Recreational/Amenity space)	(A-Deductions) 52.44
PLOT AREA FOR COVERAGE(Net Plot Area)	(A-Deductions) 64.48
Plot Area for FAR (Net Plot Area + RoadWidening Area)	(A-Deductions) 64.48
COVERAGE CHECK	
Permissible Coverage area ( 70.00 % )	45.14
Proposed Coverage Area ( 55.07 % )	35.51
Total Prop. Coverage Area ( 55.07 % )	35.51
Balance coverage area ( 14.93 % )	9.63
FAR CHECK	
Perm. FAR Area ( 1.50 )	96.72
Total Perm. FAR area	96.72
Residential FAR	71.02
Proposed FAR Area	71.02
Total Proposed FAR Area	71.02
Consumed FAR (Factor)	1.10
Balance FAR Area	25.70
BUILT UP AREA CHECK	
Total Proposed BuiltUp Area	71.02
ARCHITECT (Regd)	UPENDRA
ENGINEER (Regd)	
SUPERVISOR (Regd)	
OWNER (Regd)	SUNITA DEVI
DEVELOPMENT AUTHORITY	
	LOCAL BODY

COLOR INDEX	
PLOT BOUNDARY	Black
ABUTTING ROAD	Green
PROPOSED CONSTRUCTION	Red
COMMON PLOT	White
ROAD WIDENING AREA	Yellow
EXISTING (To be retained)	Blue
EXISTING (To be demolished)	Orange

Buildingwise Floor FAR Details

Floor Name	Building Name		Total	
	Proposed Built Up Area (Sq.mt.)	Proposed FAR Area (Sq.mt.)	Total Proposed Built Up Area (Sq.mt.)	Total FAR Area (Sq.mt.)
Ground Floor	35.51	35.51	35.51	35.51
First Floor	35.51	35.51	35.51	35.51
Terrace Floor	0.00	0.00	0.00	0.00
<b>Total :</b>	<b>71.02</b>	<b>71.02</b>	<b>71.02</b>	<b>71.02</b>

Building USE/SUBUSE Details

Building Name	Building Use	Building SubUse	Building Structure
A (SUNITA DEVI HOUSE PLAN)	Residential	Bungalow/ Dwelling / Non Apartment	Non-Highrise

LTP NAME AND SIGNATURE	STRUCTURAL ENG'S NAME AND SIGNATURE	BUILDER NAME AND SIGNATURE	DIGITAL SIGNATURE
UPENDRA JNP/ENG/0012/2017			

Proposal Basic Information

Proposal File No.	JNP/EP/0018/W10/2021
Owner Name	SUNITA DEVI
Khata No	291
Plot No	7421/7939
Village Name	Tilaiya
Use	Residential
SubUse	Bungalow/ Dwelling / Non Apartment

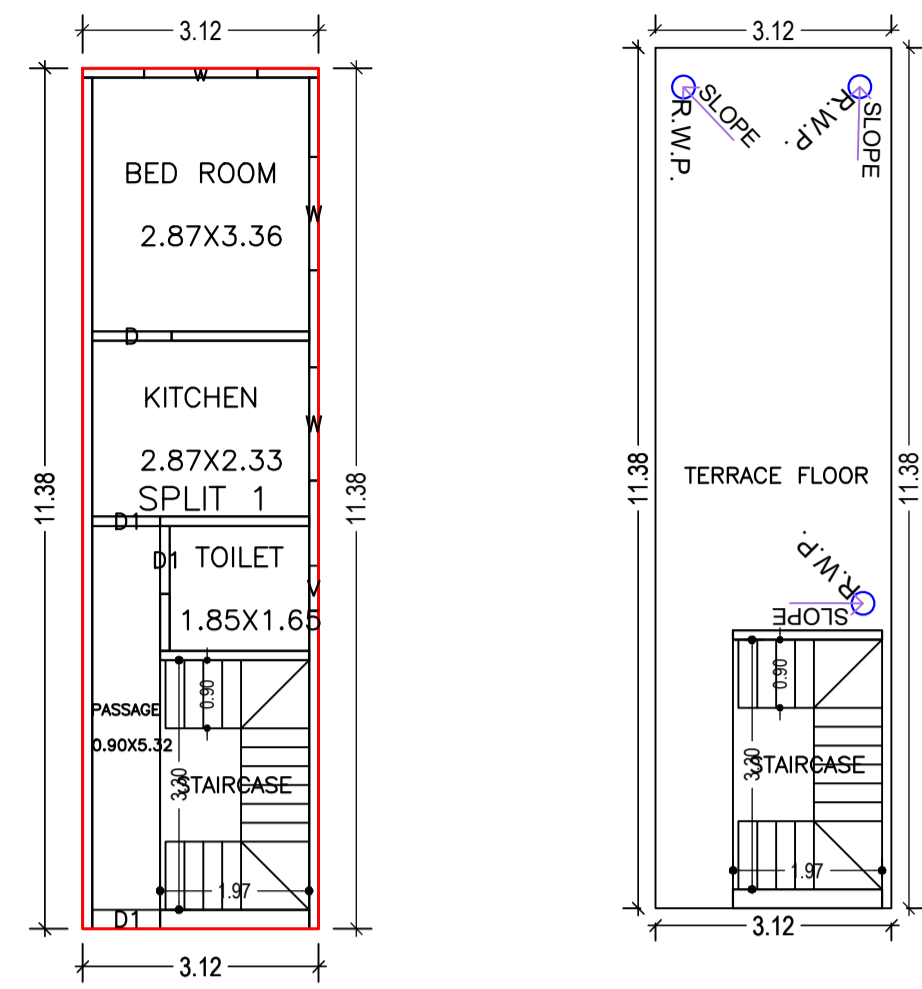

GROUND FLOOR PLAN (Proposed) (SCALE 1:100)

TERRACE FLOOR PLAN (SCALE 1:100)

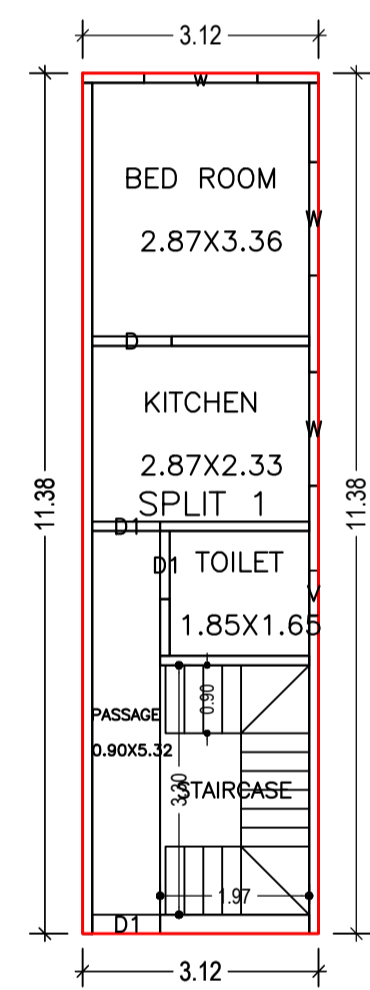
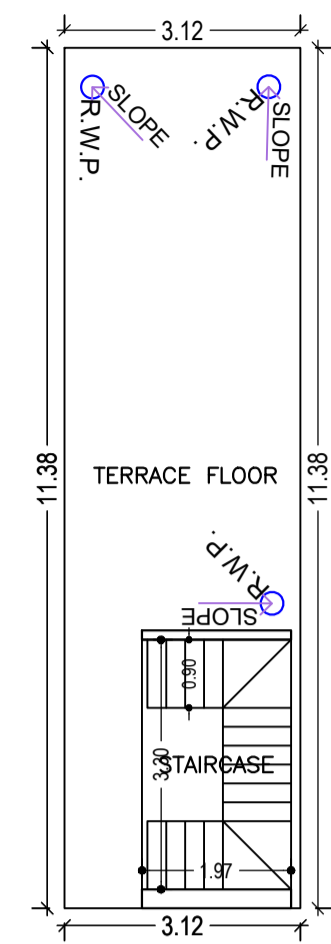

FIRST FLOOR PLAN (Proposed) (SCALE 1:100)

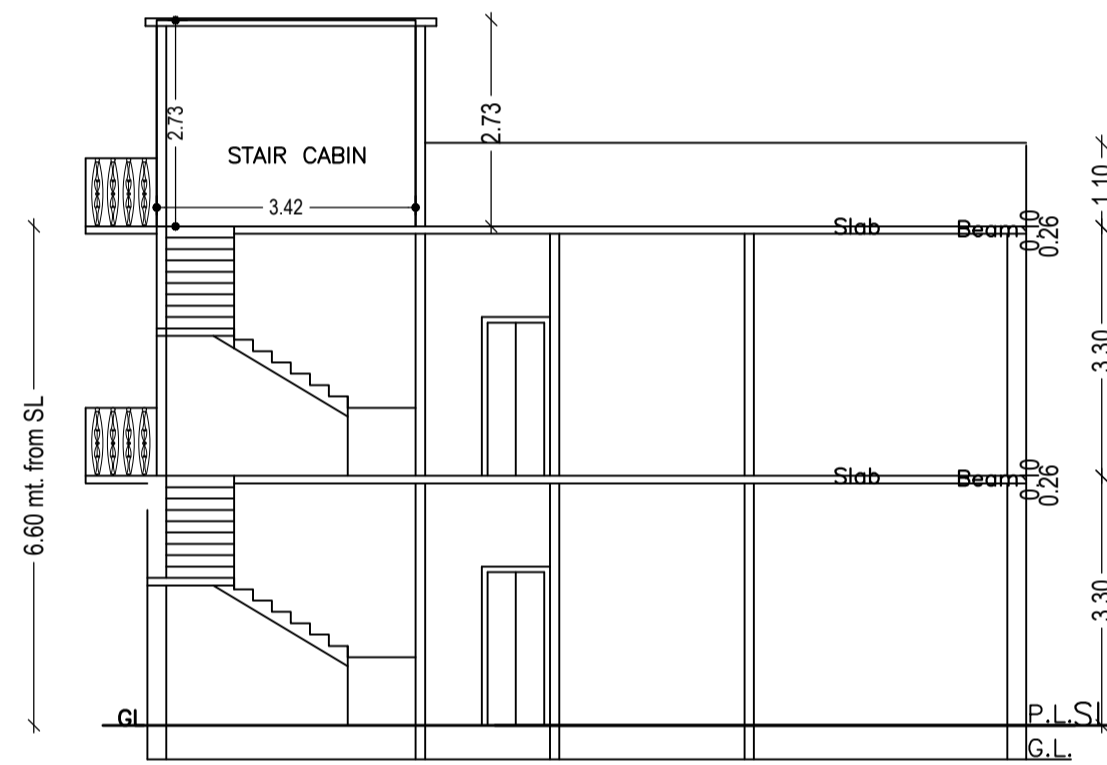

SECTION ON X-X

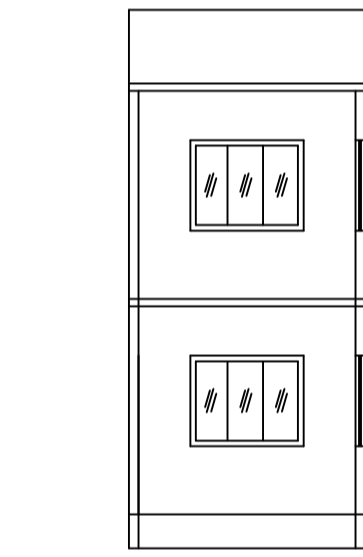

SECTION ON Y-Y

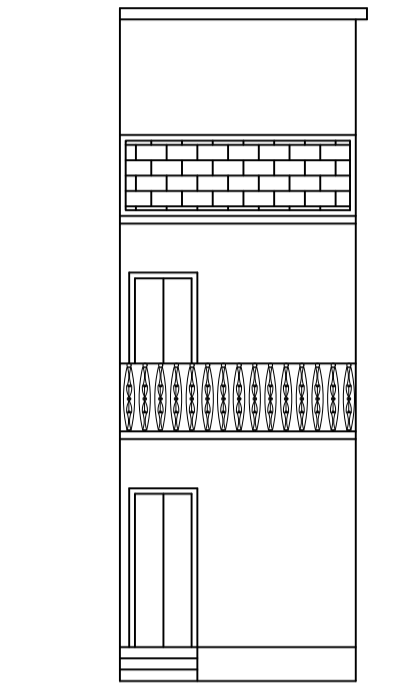
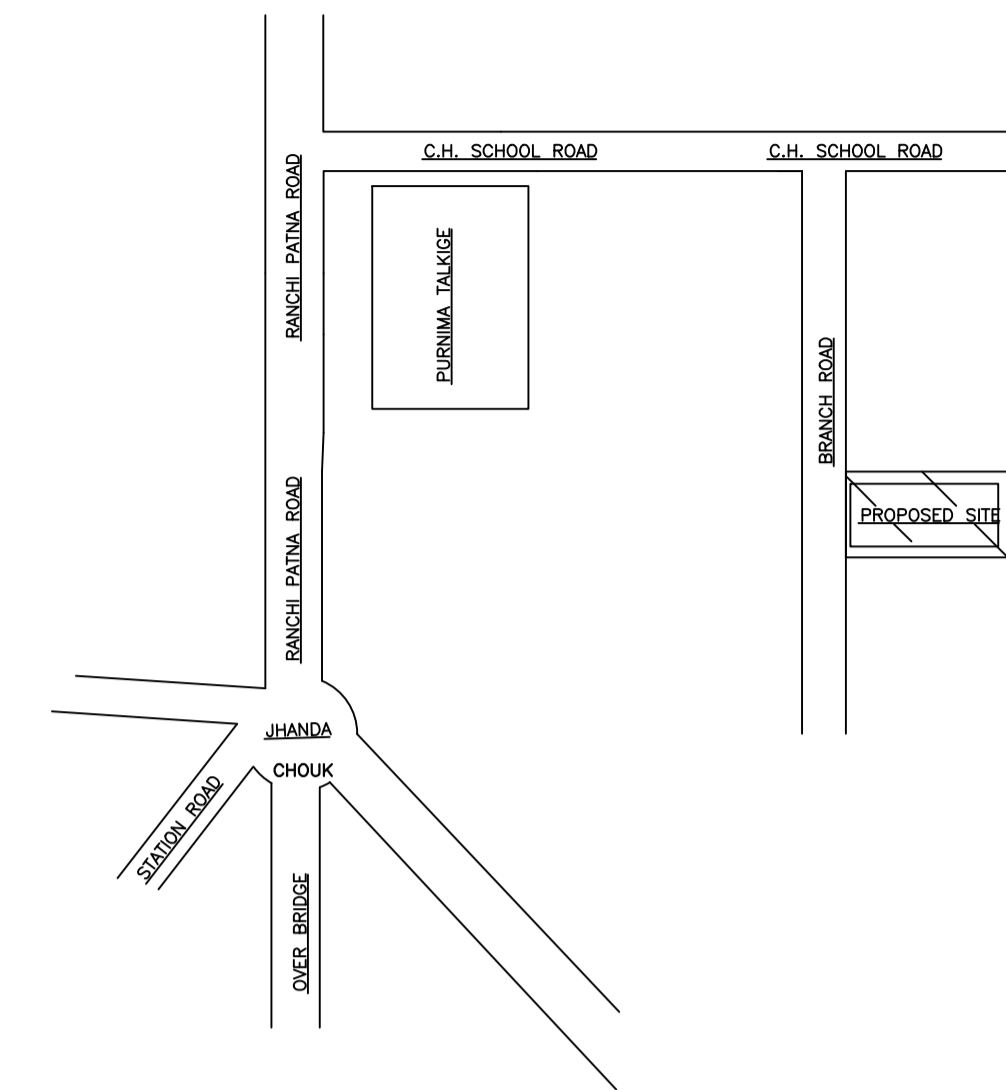

FRONT ELEVATION

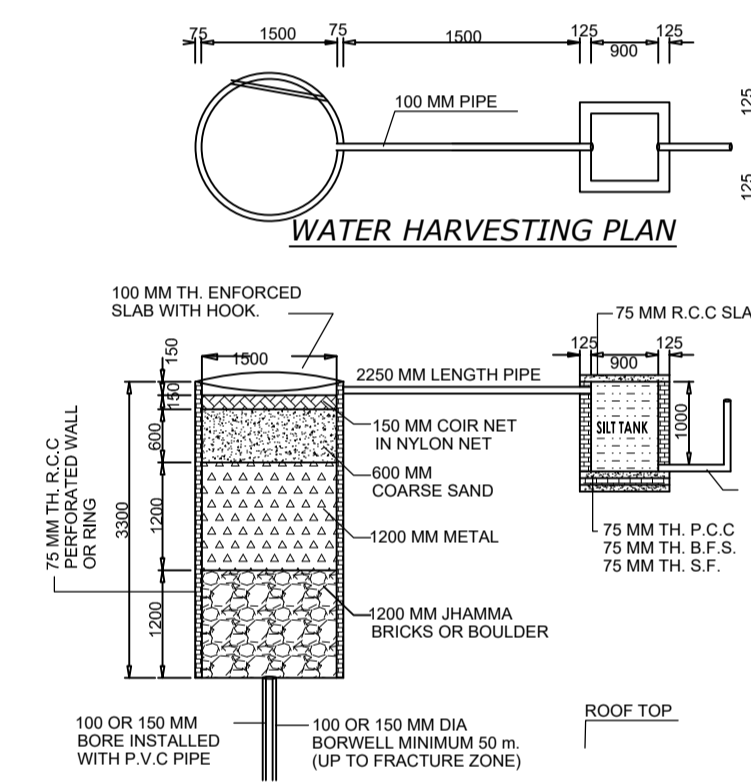

WATER HARVESTING PLAN

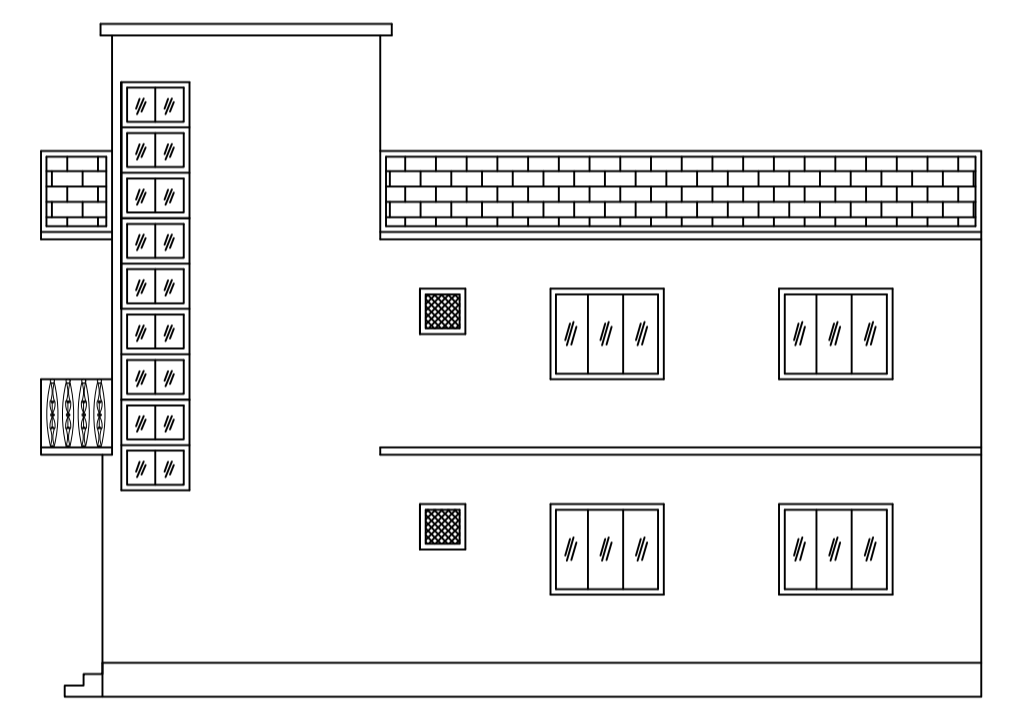

RIGHT SIDE ELEVATION

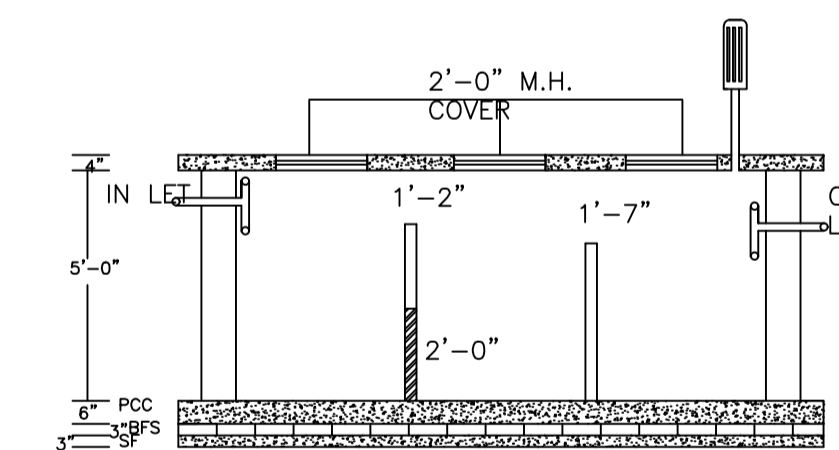

SECTION

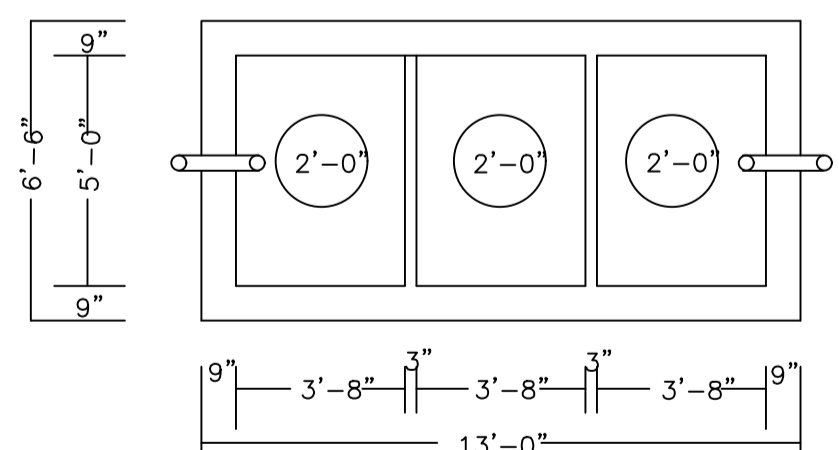

PLAN OF SEPTIC TANK (SCALE: 1/4" = 1'-0")

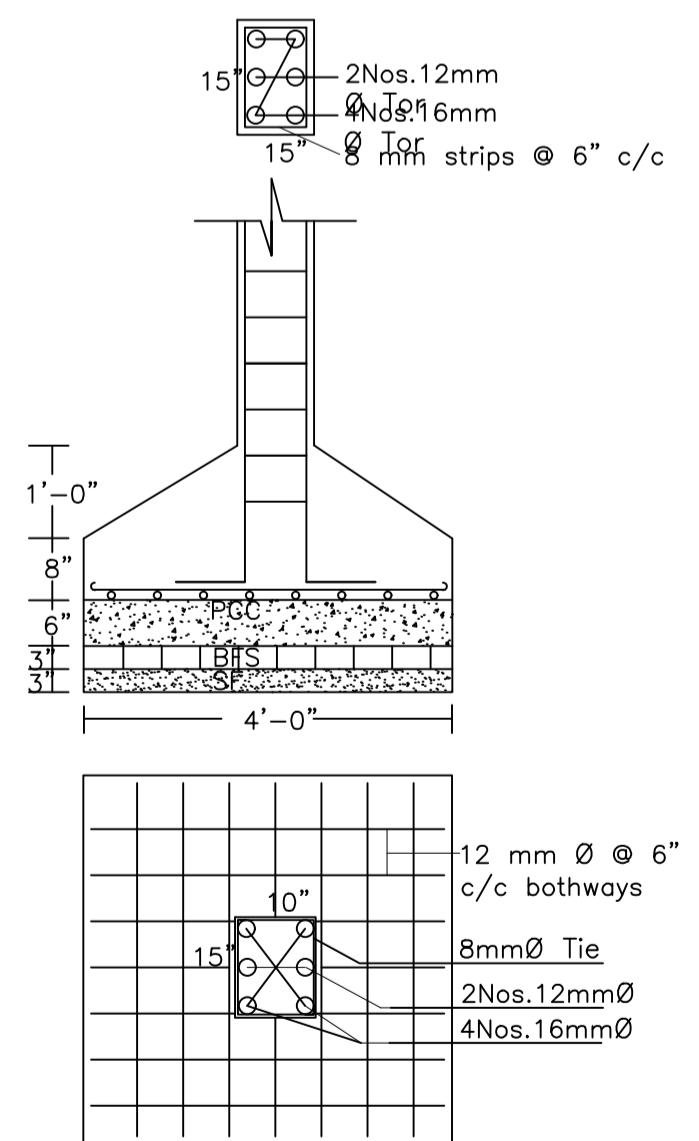

DETAILS OF COLUMNS

SCHEDULE OF DOOR:

BUILDING NAME	NAME	LENGTH	HEIGHT	NOS
A (SUNITA DEVI HOUSE PLAN)	D1	0.90	2.10	06
A (SUNITA DEVI HOUSE PLAN)	D	1.05	2.10	02

SCHEDULE OF WINDOW/VENTILATION:

BUILDING NAME	NAME	LENGTH	HEIGHT	NOS
A (SUNITA DEVI HOUSE PLAN)	V	0.60	1.20	02
A (SUNITA DEVI HOUSE PLAN)	w	1.50	1.20	02
A (SUNITA DEVI HOUSE PLAN)	W	1.50	1.20	04

UnitBUA Table for Building :A (SUNITA DEVI HOUSE PLAN)

FLOOR	Name	UnitBUA Type	UnitBUA Area	Carpet Area	No. of Rooms	No. of Tenement
GROUND FLOOR PLAN	SPLIT 1	FLAT	71.01	63.12	4	1
A (SUNITA DEVI HOUSE PLAN)	SPLIT 1	FLAT	0.00	0.00	4	0
Total:	-	-	71.01	63.12	8	1

Building :A (SUNITA DEVI HOUSE PLAN)

Floor Name	Total Built Up Area (Sq.mt.)	Proposed FAR Area (Sq.mt.)	Total FAR Area (Sq.mt.)	Total Consumed Additional FAR Area (Sq.mt.)	Tnmt (No.)
Ground Floor	35.51	35.51	35.51	35.51	01
First Floor	35.51	35.51	35.51	35.51	00
Terrace Floor	0.00	0.00	0.00	0.00	00
Total:	71.02	71.02	71.02	71.02	01
Total Number of Same Buildings	1				
Total:	71.02	71.02	71.02	71.02	01

LTP NAME AND SIGNATURE	STRUCTURAL ENG'S NAME AND SIGNATURE	BUILDER NAME AND SIGNATURE	DIGITAL SIGNATURE
UPENDRA JNP/ENG/0012/2017			