

SITE PLAN

FAR & Tenement Details (Table 4c-1)

Building	No. of Same Bldg	Total Built Up Area (Sq.mt.)	Deductions (Area in Sq.mt.)		Proposed FAR Area (Sq.mt.)	Add Area In FAR (Sq.mt.)	Total FAR Area (Sq.mt.)	Total Consumed Additional FAR Area (Sq.mt.)	Trmnt (No.)
			Parking	Resi.					
A (RESIDENTIAL)	1	316.63	26.75	278.60	11.28	289.88	289.88	01	
<b>Grand Total :</b>	<b>1</b>	<b>316.63</b>	<b>26.75</b>	<b>278.60</b>	<b>11.28</b>	<b>289.88</b>	<b>289.88</b>	<b>01</b>	

Proposal Basic Information

Proposal File No.	JNP/IB/0022/W15/2021
Owner Name	SMT SUNITA KUMARI
Khata No	476
Plot No	5519
Village Name	Tilaiya
Use	Residential
SubUse	Bungalow/ Dwelling / Non Apartment

AREA STATEMENT	VERSION NO. : 1.0.54
JHUMRITILAIYA NAGAR PARISHAD	VERSION DATE: 16/10/2020
PROJECT DETAIL:	
Region: JHARKHAND URBAN LOCAL BODIES	Plot Use: Residential
District: KODERMA	Plot SubUse: Bungalow/ Dwelling / Non Apartment
Authority: JHUMRITILAIYA NAGAR PARISHAD	PlotNearbyReligiousStructure: NA
Inward No: JNP/IB/0022/W15/2021	Plot/SubPlot No: 5519
Application Type: General Proposal	North: Road Width - 4.57
Project Type: Building Permission	South: Plot No. - SMT MEENA DEVI
Nature of Development: New	East: Plot No. - VENDOR NIJ
Location of Development Area: Old Area	West: Road Width - 3.65
AREA DETAILS:	
AREA OF PLOT (Minimum)	(A) 202.56
NET AREA OF PLOT(Gross Plot Area - Deduction from Gross Plot area)	(A-Deductions) 202.56
Deduction for Balance Plot Area(from Gross Plot Area)	
Common Plot	15.18
BALANCE AREA OF PLOT(Net Plot Area - Recreational/Amenity space)	(A-Deductions) 187.38
PLOT AREA FOR COVERAGE(Net Plot Area)	(A-Deductions) 202.56
Plot Area for FAR (Net Plot Area + RoadWidening Area)	(A-Deductions) 202.56
COVERAGE CHECK	
Permissible Coverage area ( 70.00 % )	141.79
Proposed Coverage Area ( 57.33 % )	116.12
Total Prop. Coverage Area ( 57.33 % )	116.12
Balance coverage area ( 12.67 % )	25.67
FAR CHECK	
Perm. FAR Area ( 1.50 )	303.84
Total Perm. FAR area	303.84
Residential FAR	278.60
Proposed FAR Area	289.88
Total Proposed FAR Area	289.88
Consumed FAR (Factor)	1.43
Balance FAR Area	13.96
BUILT UP AREA CHECK	
Total Proposed BuiltUp Area	316.63
ARCHITECT (Regd)	KIRAN KUMARI
ENGINEER (Regd)	
SUPERVISOR (Regd)	
OWNER (Regd)	SMT SUNITA KUMARI
DEVELOPMENT AUTHORITY	LOCAL BODY

COLOR INDEX	
PLOT BOUNDARY	Black
ABUTTING ROAD	Green
PROPOSED CONSTRUCTION	Red
COMMON PLOT	Yellow
ROAD WIDENING AREA	Blue
EXISTING (To be retained)	Blue
EXISTING (To be demolished)	Yellow

Buildingwise Floor FAR Details

Floor Name	Building Name A (RESIDENTIAL)		Total	
	Proposed Built Up Area (Sq.mt.)	Proposed FAR Area (Sq.mt.)	Total Proposed Built Up Area (Sq.mt.)	Total FAR Area (Sq.mt.)
Ground Floor	116.11	89.36	116.11	89.36
First Floor	118.28	118.28	118.28	118.28
Second Floor	82.24	82.24	82.24	82.24
Terrace Floor	0.00	0.00	0.00	0.00
<b>Total :</b>	<b>316.63</b>	<b>289.88</b>	<b>316.63</b>	<b>289.88</b>

Building USE/SUBUSE Details

Building Name	Building Use	Building SubUse	Building Structure
A (RESIDENTIAL)	Residential	Bungalow/ Dwelling / Non Apartment	Non-Highrise

LTP NAME AND SIGNATURE	STRUCTURAL ENG'S NAME AND SIGNATURE	BUILDER NAME AND SIGNATURE	DIGITAL SIGNATURE
KIRAN KUMARI JNP/ENG/001/2019			

Proposal Basic Information	
Proposal File No.	JNP/IB/0022/W15/2021
Owner Name	SMT SUNITA KUMARI
Khata No	476
Plot No	5519
Village Name	Tilaiya
Use	Residential
SubUse	Bungalow/ Dwelling / Non Apartment

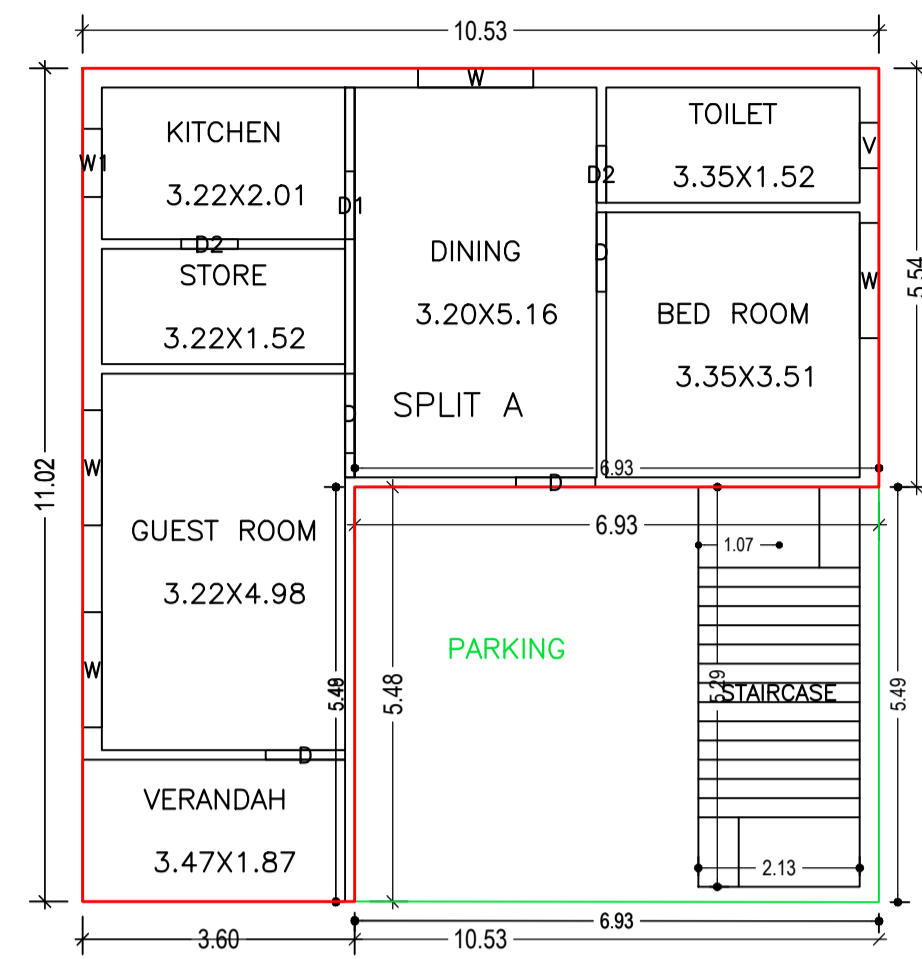

GROUND FLOOR PLAN (Proposed) (SCALE 1:100)

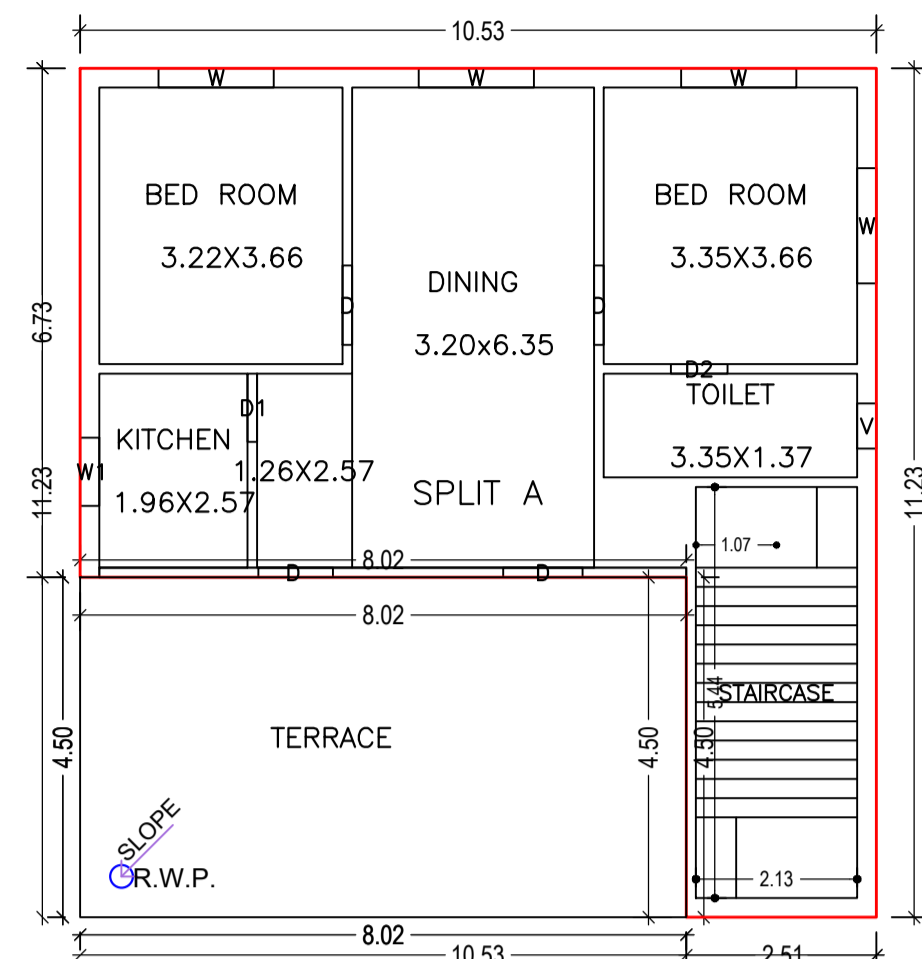

SECOND FLOOR PLAN (Proposed) (SCALE 1:100)

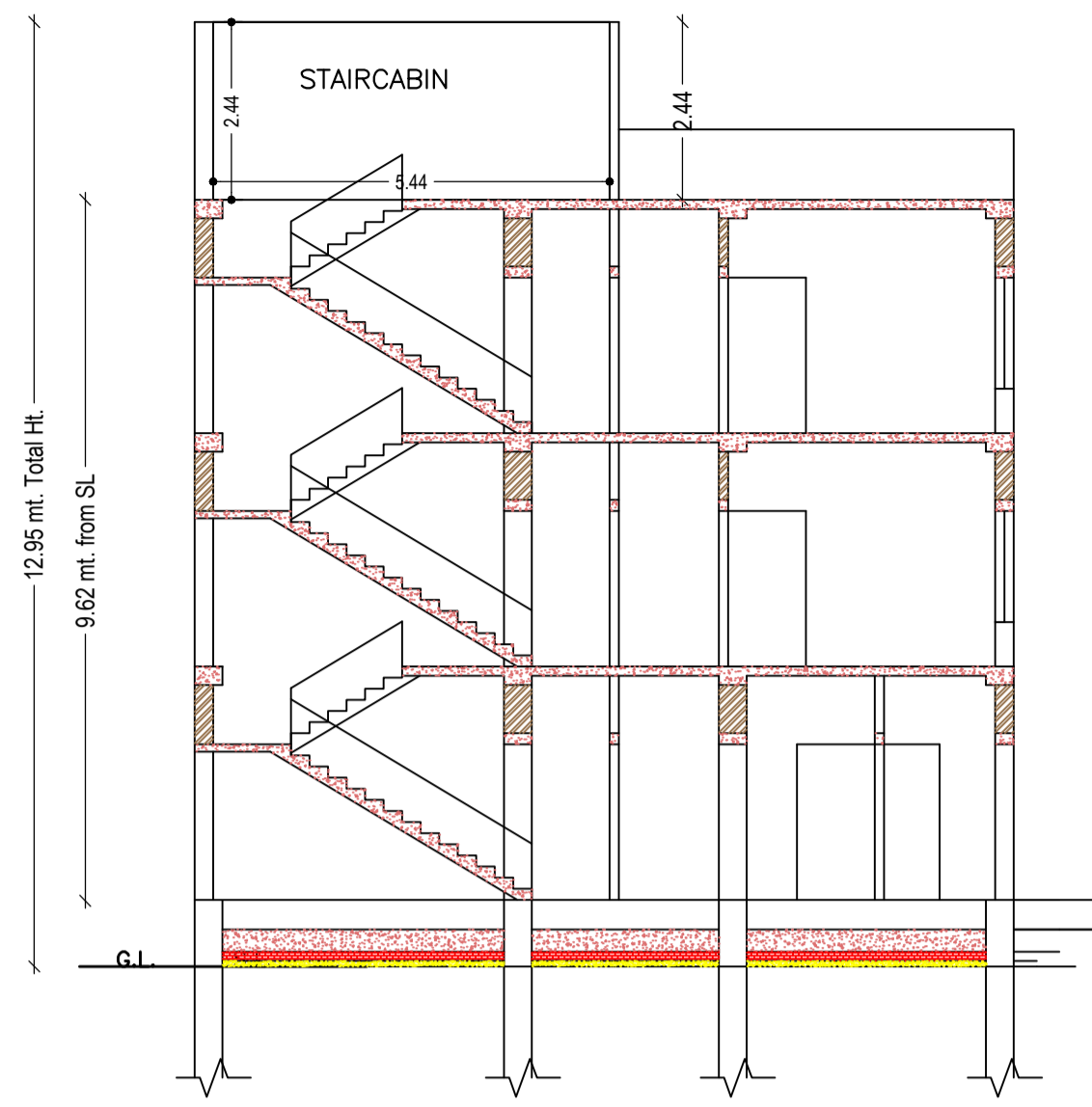

CROSS SECTION (A)

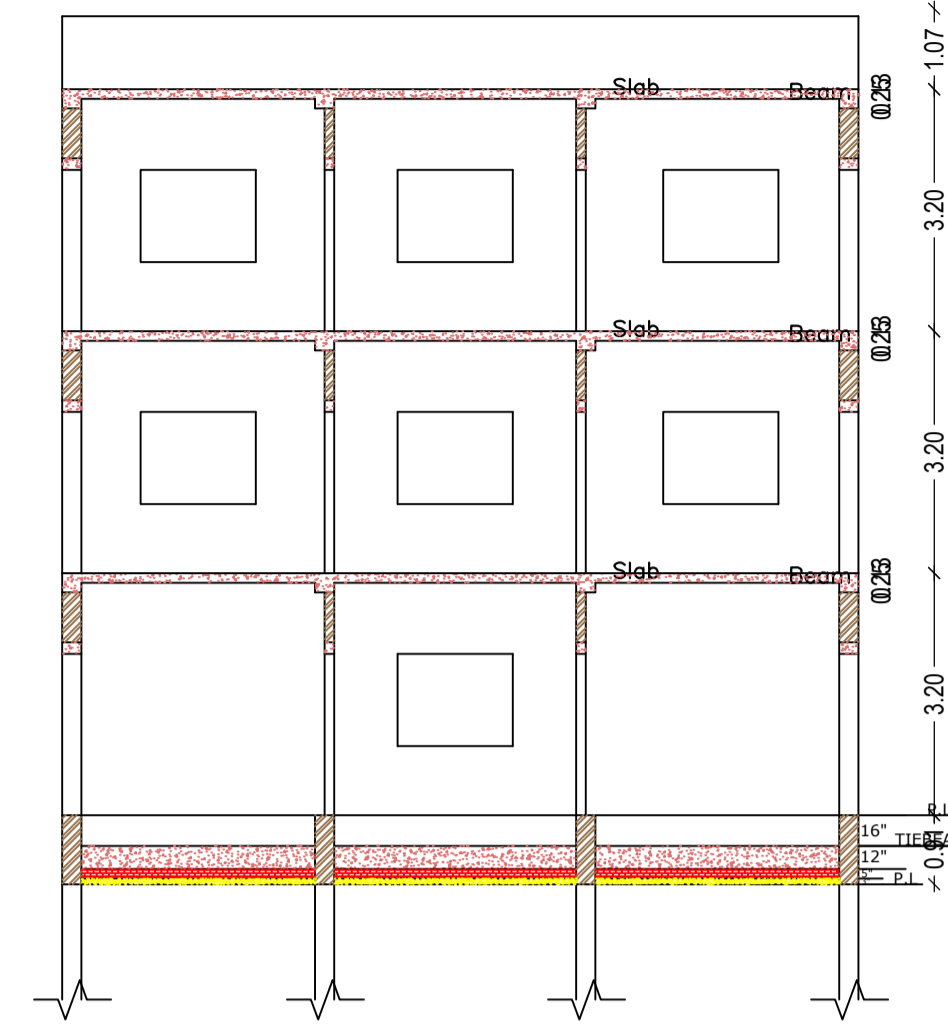

CROSS SECTION (B)

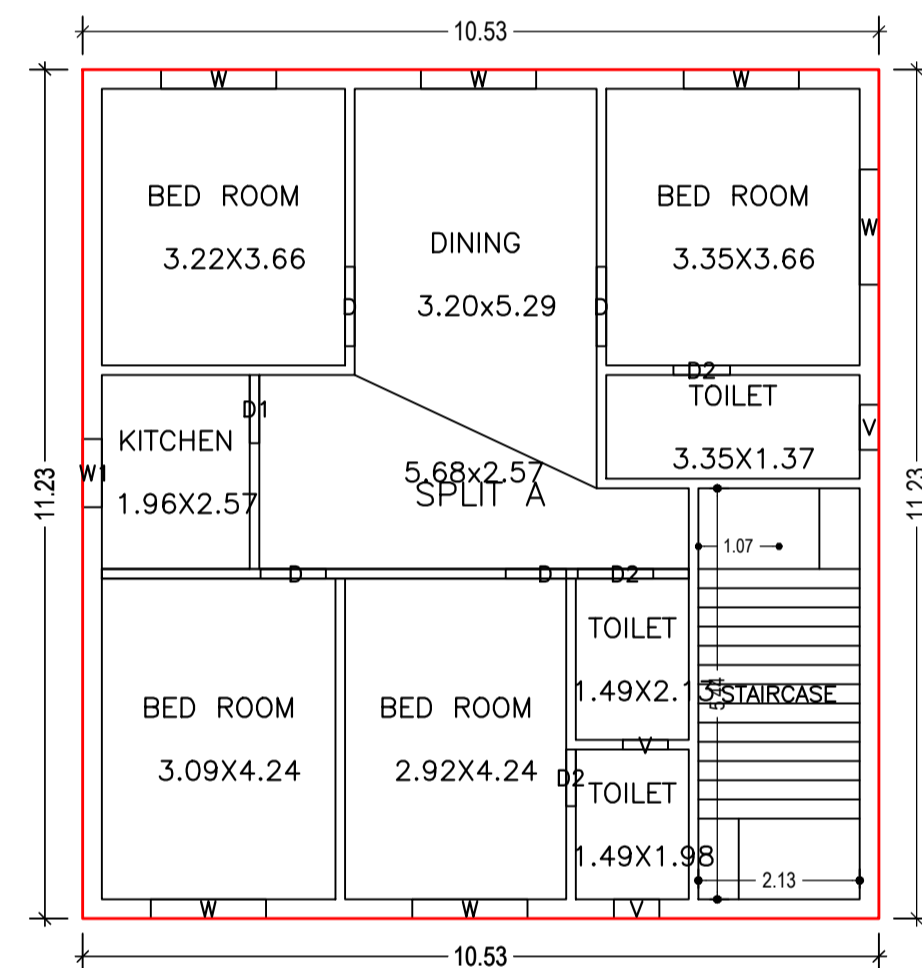

FIRST FLOOR PLAN (Proposed) (SCALE 1:100)

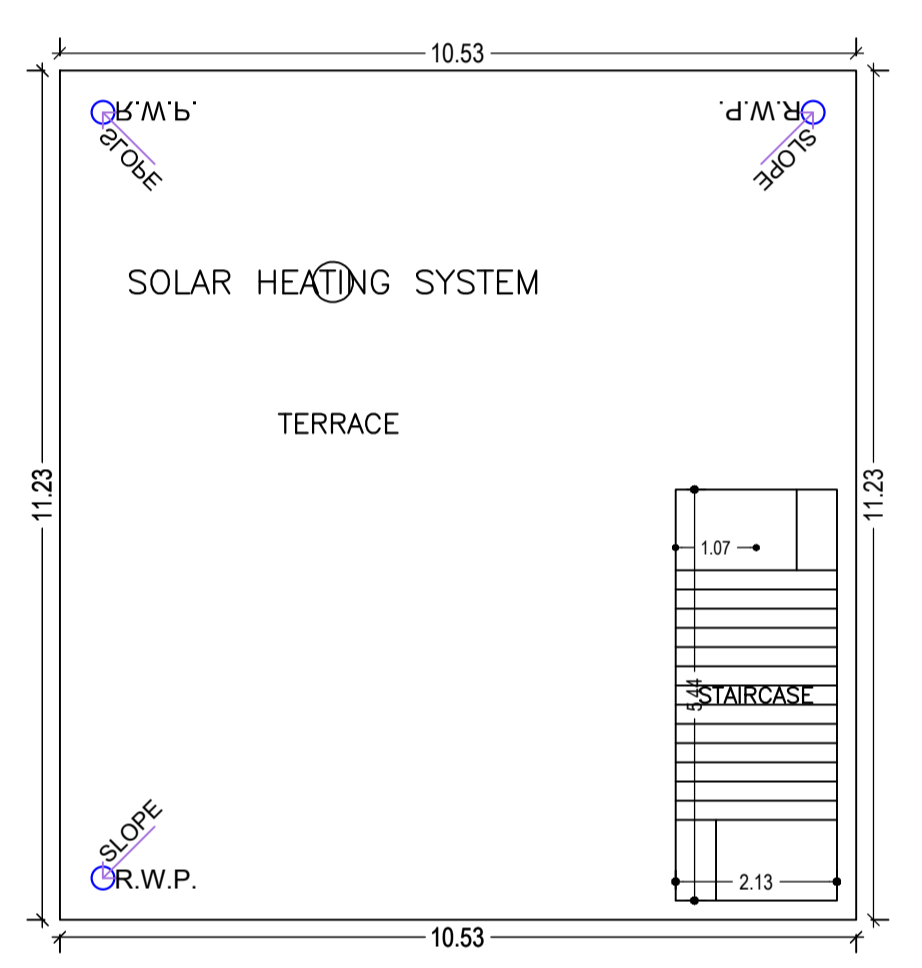

TERRACE FLOOR PLAN (SCALE 1:100)

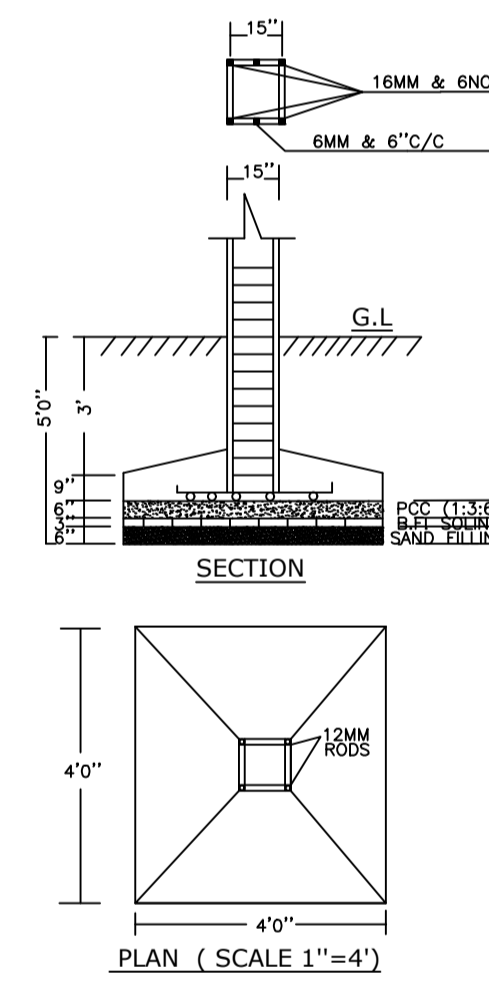

SECTION

PLAN (SCALE 1"=4')

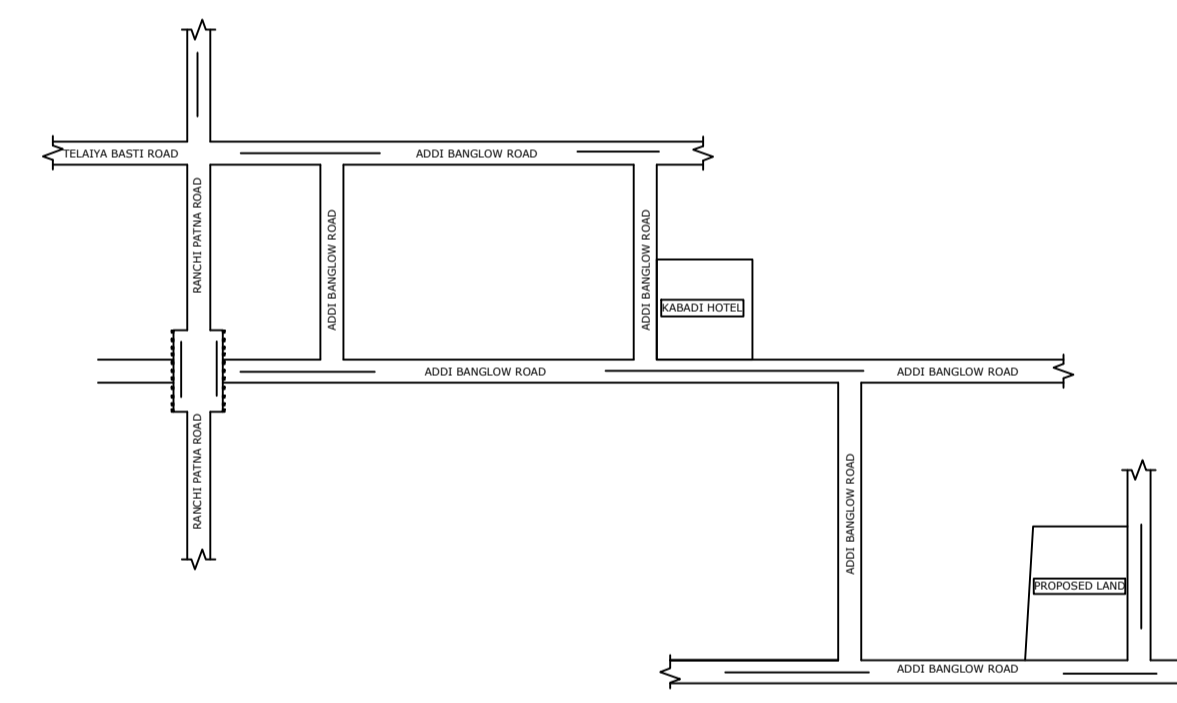

LOCATION PLAN (SCALE -1"=16')

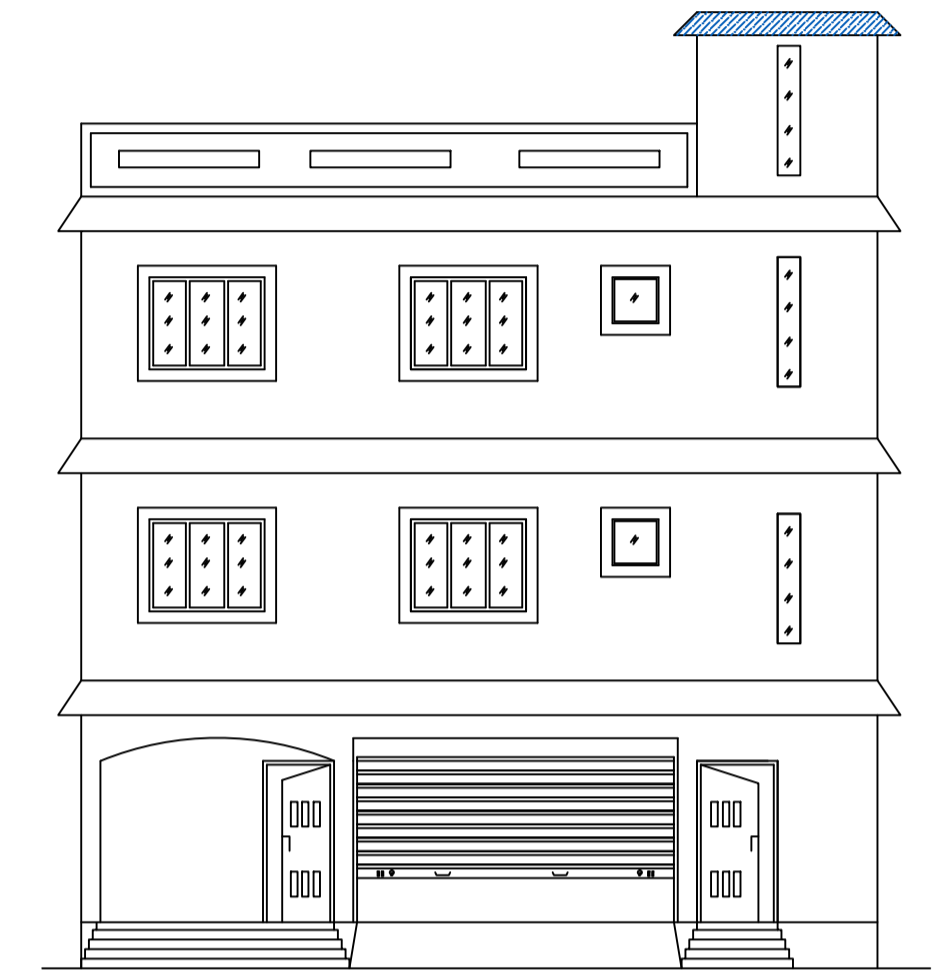

FRONT ELEVATION

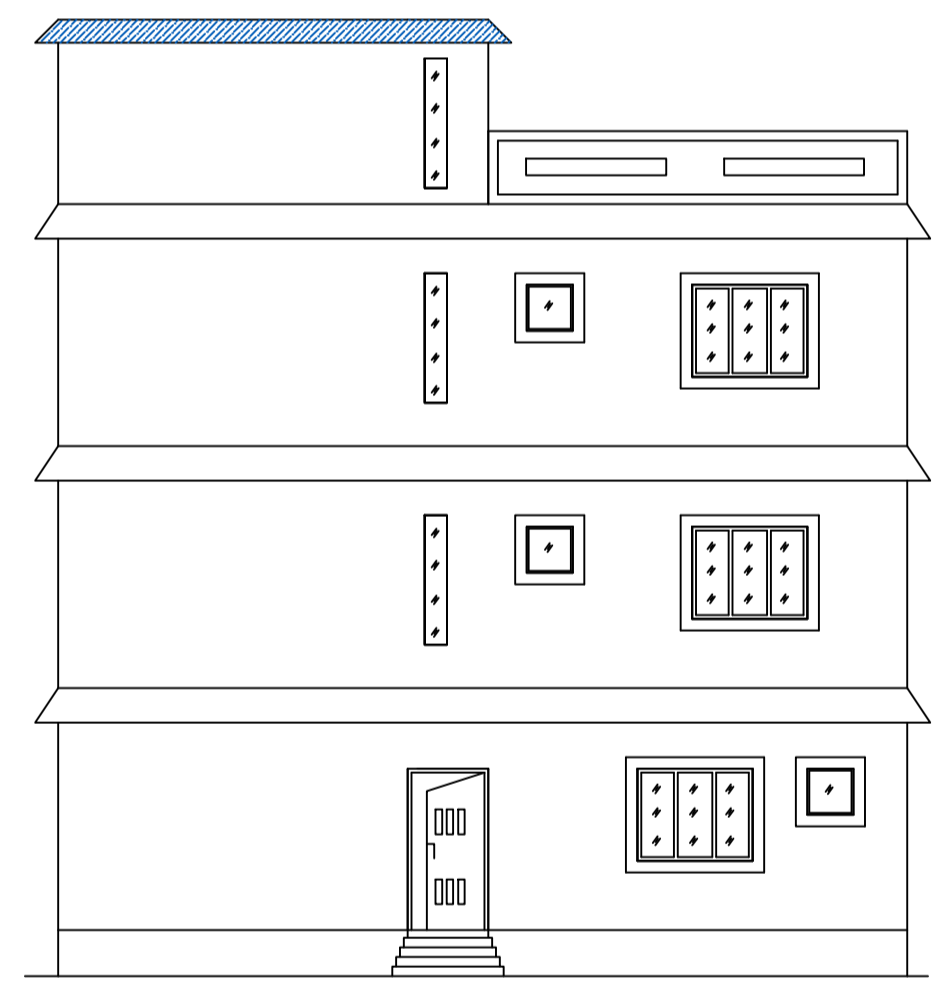

CROSS ELEVATION

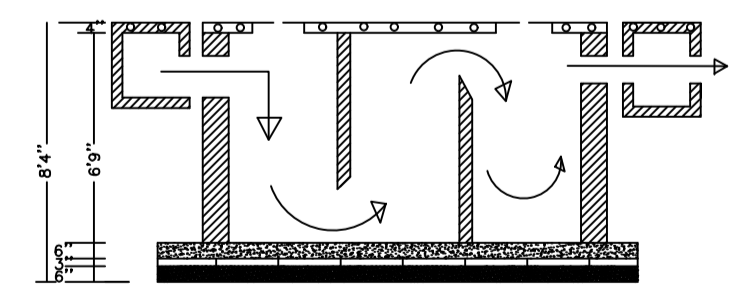

SECTION

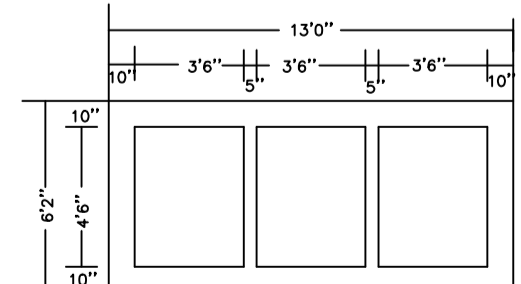

PLAN OF SEPTIC TANK

Building :A (RESIDENTIAL)

Floor Name	Total Built Up Area (Sq.mt.)	Deductions (Area in Sq.mt.)	Proposed FAR Area (Sq.mt.)	Add Area In FAR (Sq.mt.)	Total FAR Area (Sq.mt.)	Total Consumed Additional FAR Area (Sq.mt.)	Trmt (No.)
Ground Floor	116.11	26.75	78.06	11.28	89.36	89.36	01
First Floor	118.28	0.00	118.28	0.00	118.28	118.28	00
Second Floor	82.24	0.00	82.24	0.00	82.24	82.24	00
Terrace Floor	0.00	0.00	0.00	0.00	0.00	0.00	00
Total :	316.63	26.75	278.60	11.28	289.88	289.88	01
Total Number of Same Buildings	1						
Total :	316.63	26.75	278.60	11.28	289.88	289.88	01

SCHEDULE OF DOOR:

BUILDING NAME	NAME	LENGTH	HEIGHT	NOS
A (RESIDENTIAL)	D2	0.75	2.10	05
A (RESIDENTIAL)	D	0.80	2.10	01
A (RESIDENTIAL)	D	0.86	2.10	01
A (RESIDENTIAL)	D1	0.90	2.10	03
A (RESIDENTIAL)	D	0.99	2.10	01
A (RESIDENTIAL)	D2	1.00	2.10	01
A (RESIDENTIAL)	D	1.05	2.10	09

SCHEDULE OF WINDOW/VENTILATION:

BUILDING NAME	NAME	LENGTH	HEIGHT	NOS
A (RESIDENTIAL)	V	0.60	0.75	05
A (RESIDENTIAL)	W1	0.90	1.20	03
A (RESIDENTIAL)	W	1.52	1.20	14

UnitBUA Table for Building :A (RESIDENTIAL)

FLOOR	Name	UnitBUA Type	UnitBUA Area	Carpet Area	No. of Rooms	No. of Tenement
GROUND FLOOR PLAN	SPLIT A	FLAT	227.85	225.22	7	1
FIRST FLOOR PLAN	SPLIT A	FLAT	0.00	0.00	9	0
SECOND FLOOR PLAN	SPLIT A	FLAT	0.00	0.00	5	0
Total:	-	-	227.85	225.22	21	1

LTP NAME AND SIGNATURE	STRUCTURAL ENG'S NAME AND SIGNATURE	BUILDER NAME AND SIGNATURE	DIGITAL SIGNATURE
KIRAN KUMARI JNP/ENG/0001/2019			