

SITE PLAN

FAR & Tenement Details (Table 4c-1)

Building	No. of Same Bldg	Total Built Up Area (Sq.mt.)	Deductions (Area in Sq.mt.)		Proposed FAR Area (Sq.mt.)	Add Area In FAR (Sq.mt.)	Total FAR Area (Sq.mt.)	Total Consumed Additional FAR Area (Sq.mt.)	Trmnt (No.)
			Parking	Resi.					
A (RESIDENTIAL)	1	386.94	111.91	263.98	11.06	275.03	275.03	01	
Grand Total :	1	386.94	111.91	263.98	11.06	275.03	275.03	01	

Proposal Basic Information

Proposal File No.	JNP/BI/0021/W14/2021
Owner Name	SRI DEEP PRAKASH
Khata No	381
Plot No	7109
Village Name	Tilaiya
Use	Residential
SubUse	Bungalow/ Dwelling / Non Apartment

AREA STATEMENT	VERSION NO. : 1.0.54
JHUMRITILAIYA NAGAR PARISHAD	VERSION DATE: 16/10/2020
PROJECT DETAIL:	
Region: JHARKHAND URBAN LOCAL BODIES	Plot Use: Residential
District: KODERMA	Plot SubUse: Bungalow/ Dwelling / Non Apartment
Authority: JHUMRITILAIYA NAGAR PARISHAD	PlotNearbyReligiousStructure: NA
Inward No: JNP/BI/0021/W14/2021	Plot/SubPlot No: 7109
Application Type: General Proposal	North: Road Width - 4.57
Project Type: Building Permission	South: Plot No. - LAND OF DIVINE UNITED ORGANISATION
Nature of Development: New	East: Plot No. - LAND OF MAHESH KUMAR AGARWAL
Location of Development Area: Old Area	West: Plot No. - BLOCK NO D/15
AREA DETAILS:	
AREA OF PLOT (Minimum)	(A) 185.68
NET AREA OF PLOT(Gross Plot Area - Deduction from Gross Plot area)	(A-Deductions) 185.68
Deduction for Balance Plot Area(from Gross Plot Area)	
Total	13.54
BALANCE AREA OF PLOT(Net Plot Area - Recreational/Amenity space)	(A-Deductions) 172.14
PLOT AREA FOR COVERAGE(Net Plot Area)	(A-Deductions) 185.68
Plot Area for FAR (Net Plot Area + Road Widening Area)	(A-Deductions) 185.68
COVERAGE CHECK	
Permissible Coverage area (70.00 %)	129.98
Proposed Coverage Area (68.89 %)	127.91
Total Prop. Coverage Area (68.89 %)	127.91
Balance coverage area (1.11 %)	2.07
FAR CHECK	
Perm. FAR Area (1.50)	278.52
Total Perm. FAR area	278.52
Residential FAR	263.98
Proposed FAR Area	275.03
Total Proposed FAR Area	275.03
Consumed FAR (Factor)	1.48
Balance FAR Area	3.49
BUILT UP AREA CHECK	
Total Proposed BuiltUp Area	386.94
ARCHITECT (Regd)	KIRAN KUMARI
ENGINEER (Regd)	
SUPERVISOR (Regd)	
OWNER (Regd)	SRI DEEP PRAKASH
DEVELOPMENT AUTHORITY	LOCAL BODY

COLOR INDEX	
PLOT BOUNDARY	Black
ABUTTING ROAD	Green
PROPOSED CONSTRUCTION	Red
COMMON PLOT	Yellow
ROAD WIDENING AREA	Blue
EXISTING (To be retained)	Blue
EXISTING (To be demolished)	Yellow

Buildingwise Floor FAR Details

Floor Name	Building Name A (RESIDENTIAL)		Total	
	Proposed Built Up Area (Sq.mt.)	Proposed FAR Area (Sq.mt.)	Total Proposed Built Up Area (Sq.mt.)	Total FAR Area (Sq.mt.)
Ground Floor	127.90	15.99	127.90	15.99
First Floor	129.52	129.52	129.52	129.52
Second Floor	129.52	129.52	129.52	129.52
Terrace Floor	0.00	0.00	0.00	0.00
Total :	386.94	275.03	386.94	275.03

Building USE/SUBUSE Details

Building Name	Building Use	Building SubUse	Building Structure
A (RESIDENTIAL)	Residential	Bungalow/ Dwelling / Non Apartment	Non-Highrise

LTP NAME AND SIGNATURE	STRUCTURAL ENG'S NAME AND SIGNATURE	BUILDER NAME AND SIGNATURE	DIGITAL SIGNATURE
KIRAN KUMARI JNP/ENG/0001/2019			

Proposal Basic Information	
Proposal File No.	JNP/IB/0021/W14/2021
Owner Name	SRI DEEP PRAKASH
Khata No	381
Plot No	7109
Village Name	Tilaiya
Use	Residential
SubUse	Bungalow/ Dwelling / Non Apartment

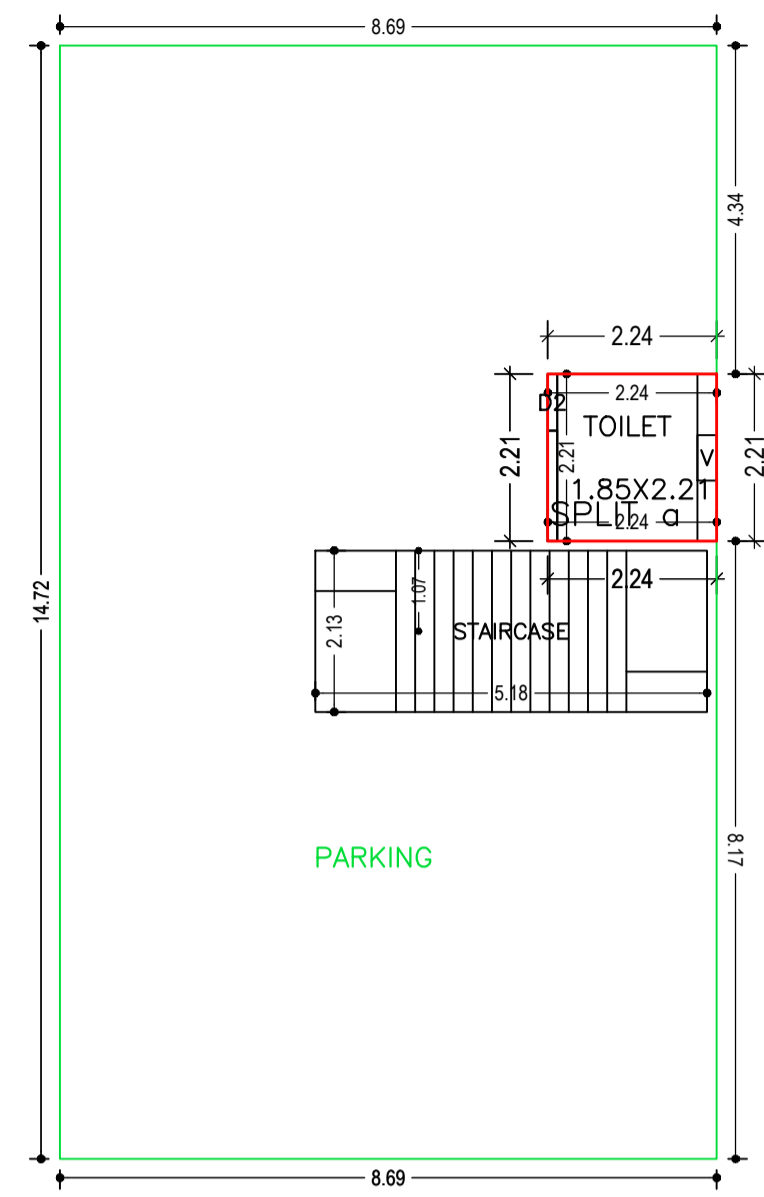

GROUND FLOOR PLAN (Proposed) (SCALE 1:100)

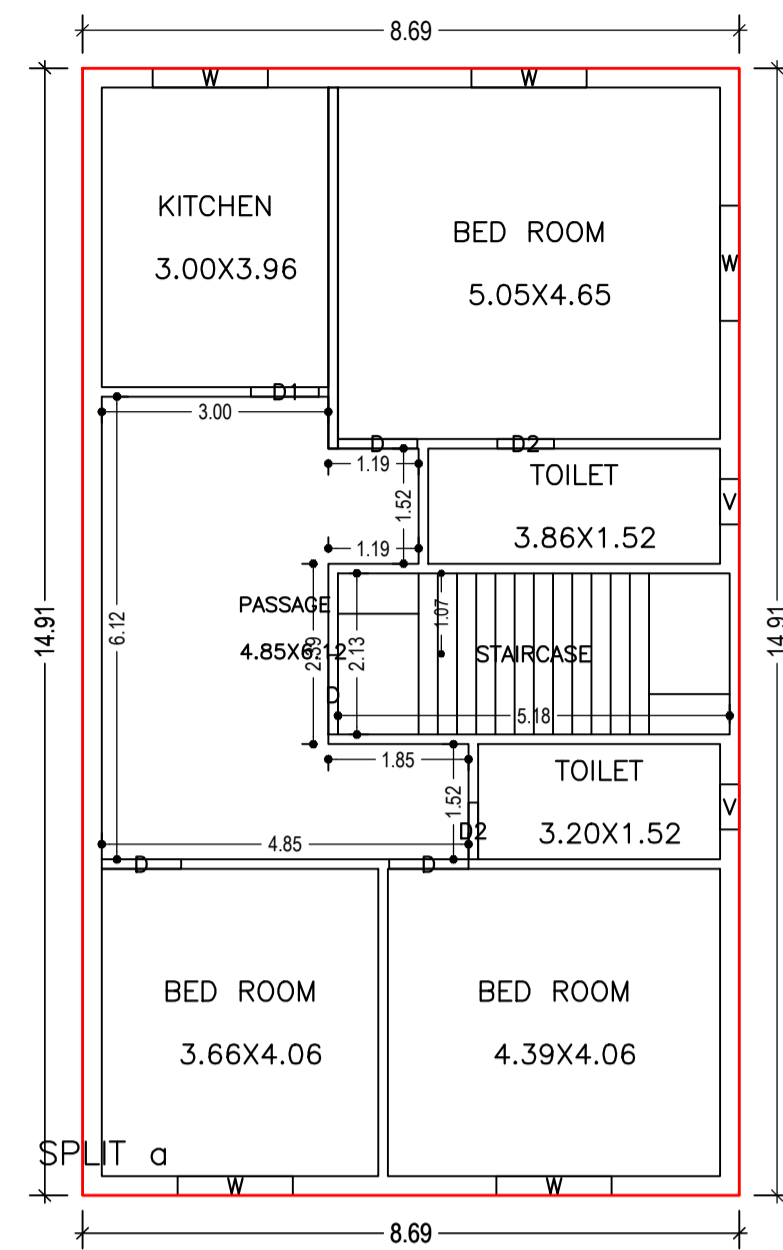

SECOND FLOOR PLAN (Proposed) (SCALE 1:100)

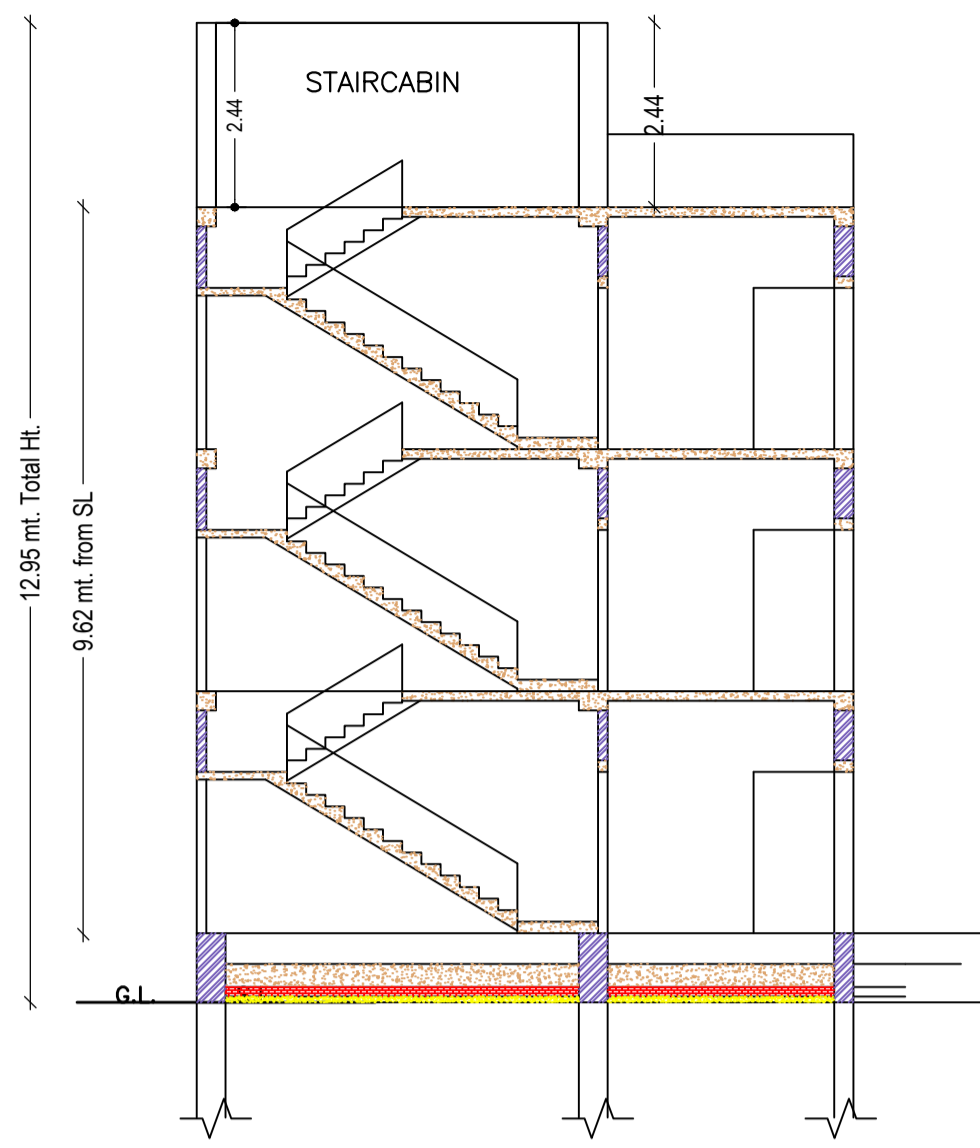

CROSS SECTION (A)

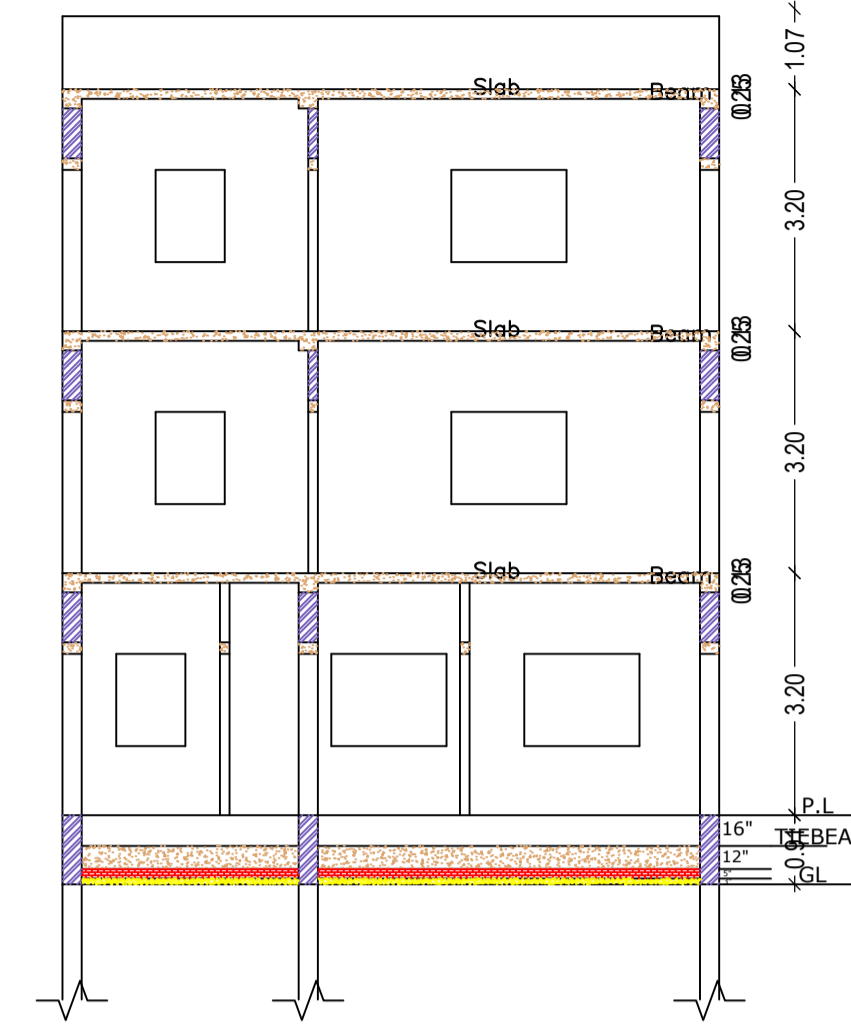

CROSS SECTION (B)

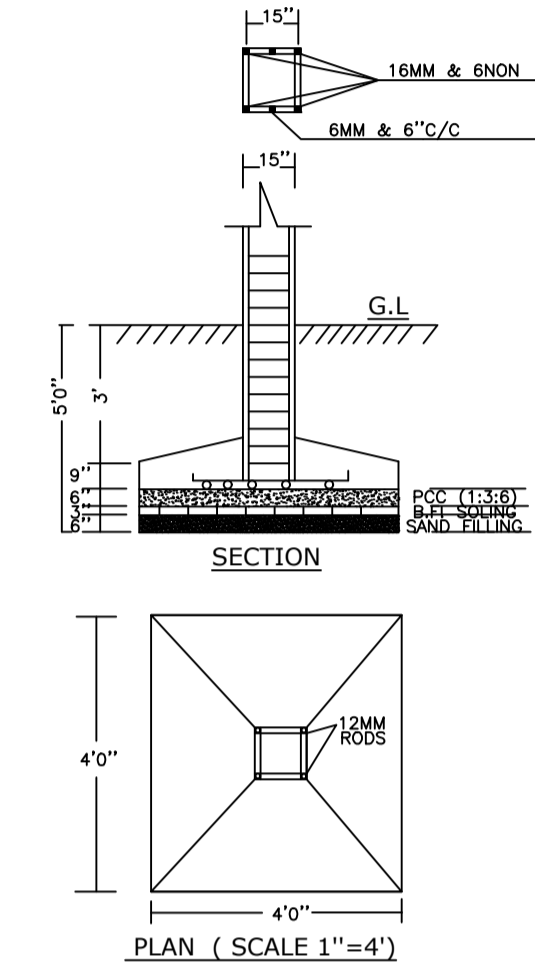

PLAN (SCALE 1"=4')

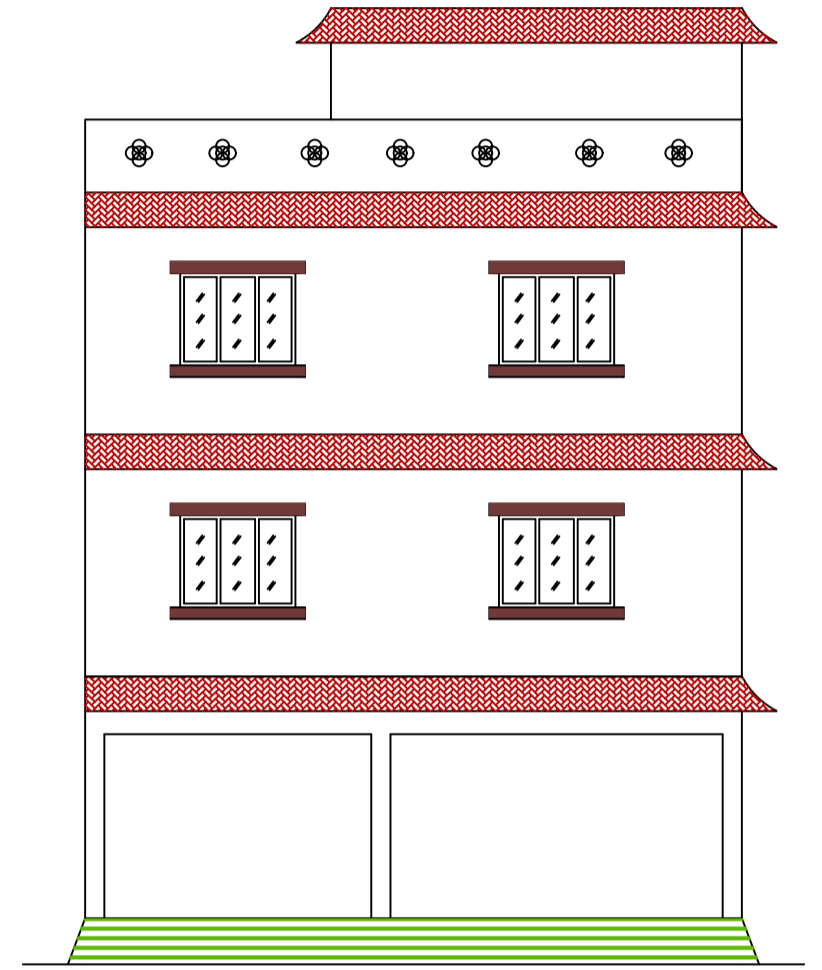

FRONT ELEVATION

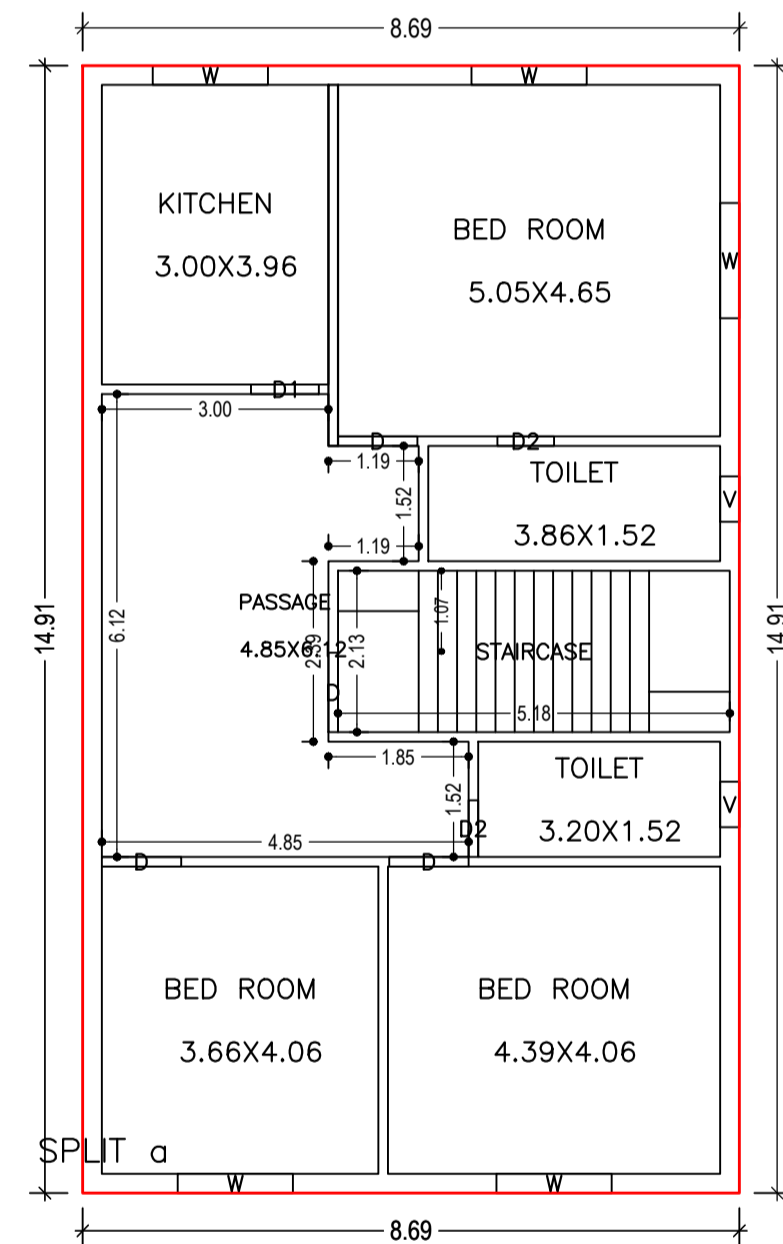

FIRST FLOOR PLAN (Proposed) (SCALE 1:100)

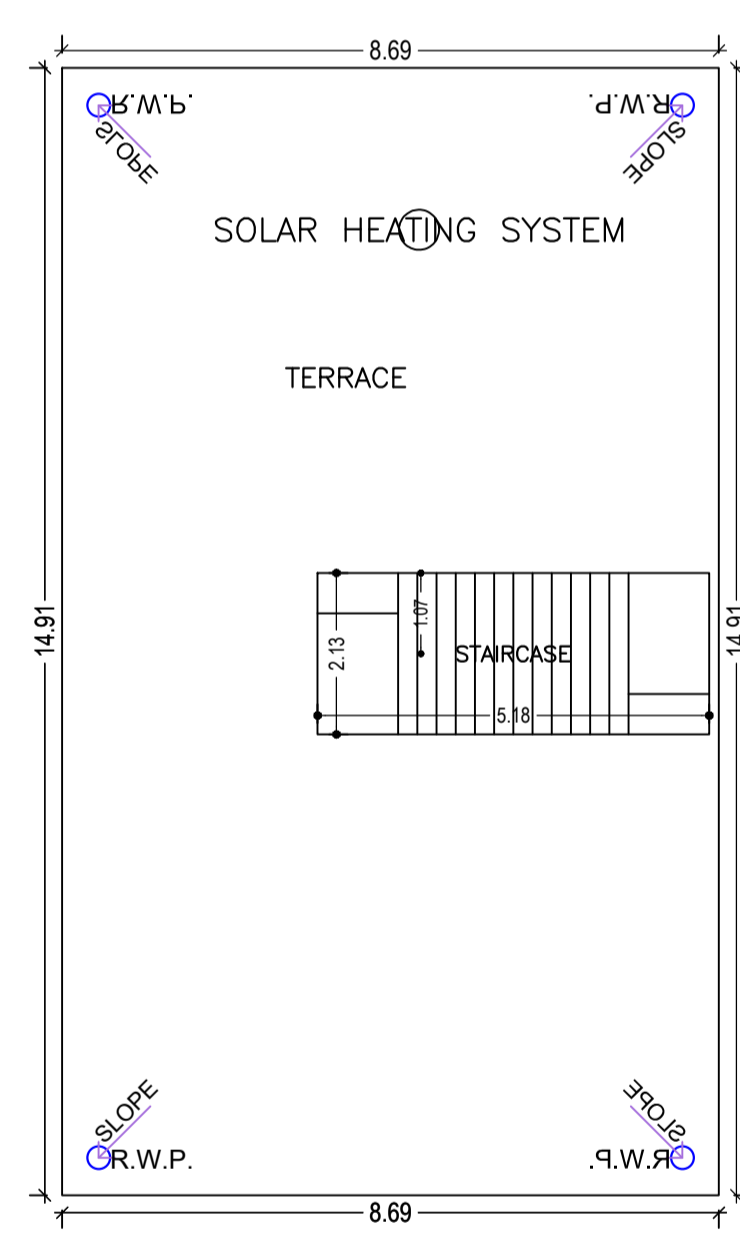

TERRACE FLOOR PLAN (SCALE 1:100)

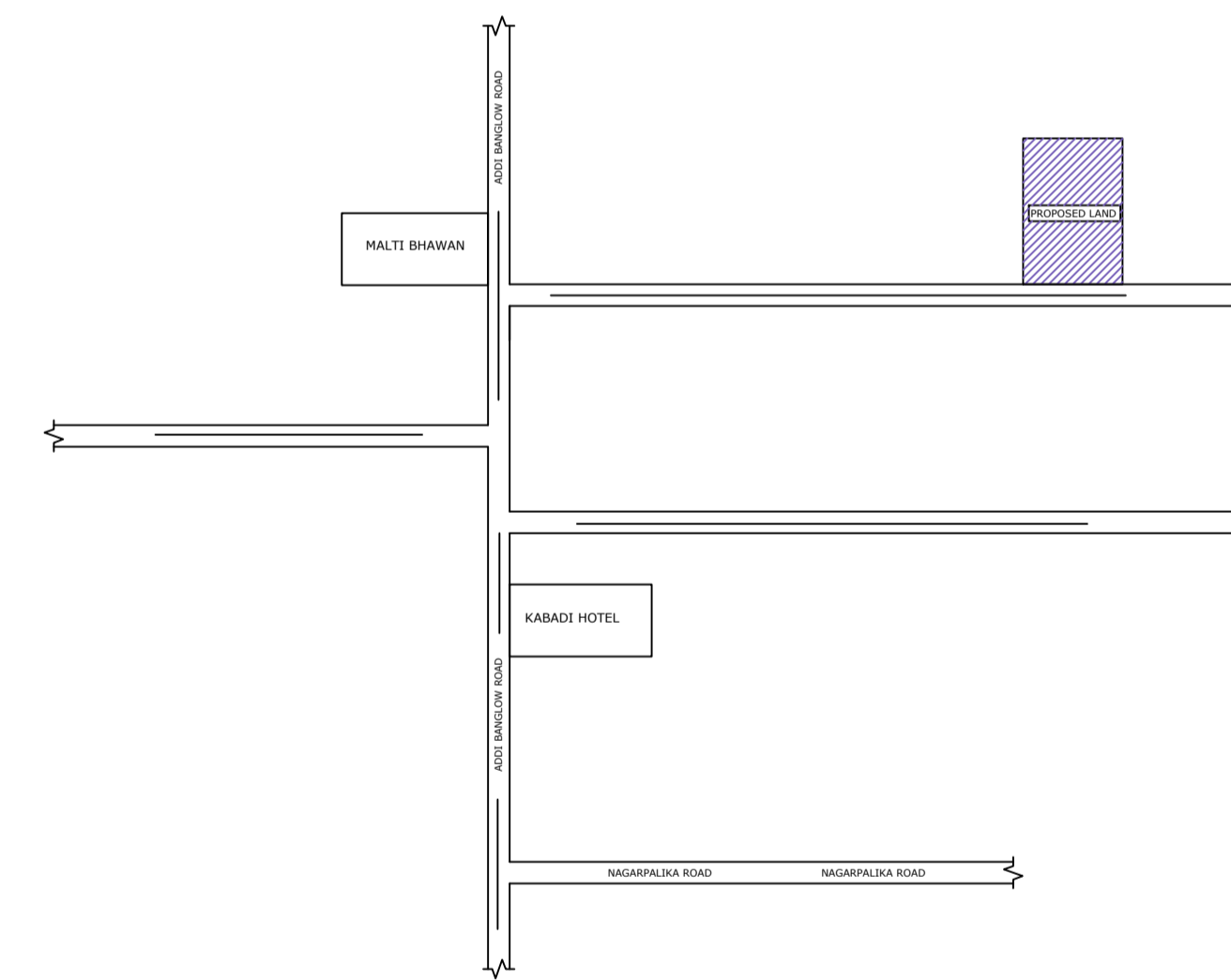

LOCATION PLAN (SCALE -1"=16')

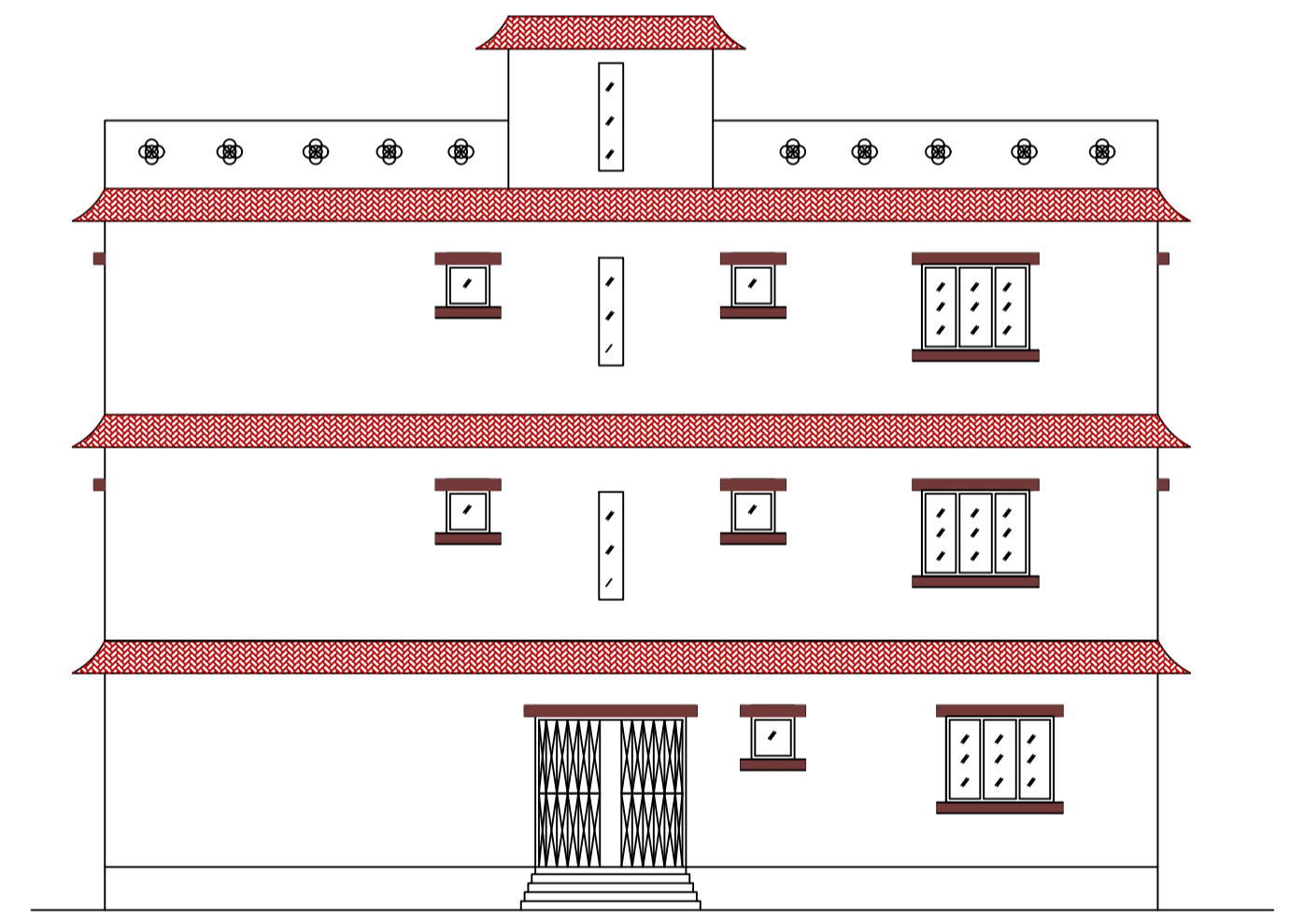

CROSS ELEVATION

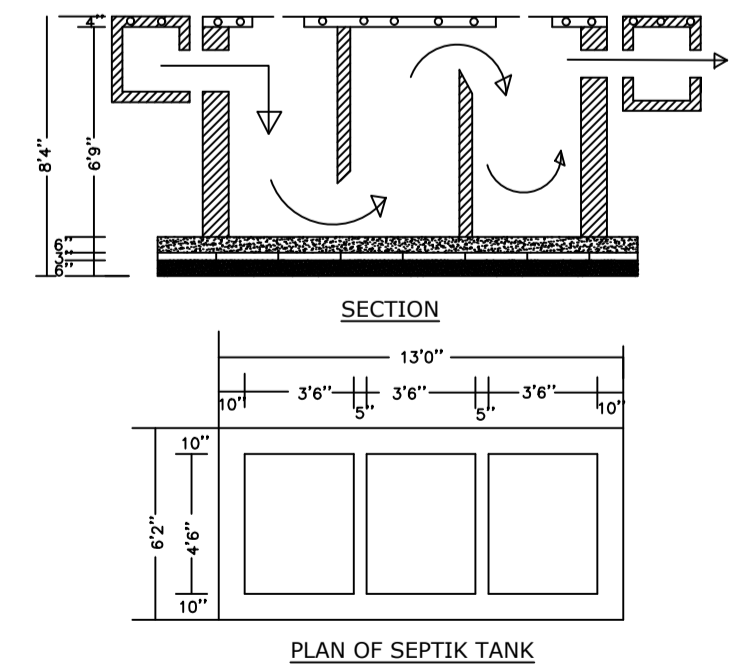

PLAN OF SEPTIK TANK

Building :A (RESIDENTIAL)

Floor Name	Total Built Up Area (Sq.mt.)	Deductions (Area in Sq.mt.)	Proposed FAR Area (Sq.mt.)	Add Area in FAR (Sq.mt.)	Total FAR Area (Sq.mt.)	Total Consumed Additional FAR Area (Sq.mt.)	Trmt (No.)
Ground Floor	127.90	111.91	4.94	11.06	15.99	15.99	01
First Floor	129.52	0.00	129.52	0.00	129.52	129.52	00
Second Floor	129.52	0.00	129.52	0.00	129.52	129.52	00
Terrace Floor	0.00	0.00	0.00	0.00	0.00	0.00	00
Total :	386.94	111.91	263.98	11.06	275.03	275.03	01
Total Number of Same Buildings	1						
Total :	386.94	111.91	263.98	11.06	275.03	275.03	01

SCHEDULE OF DOOR:

BUILDING NAME	NAME	LENGTH	HEIGHT	NOS
A (RESIDENTIAL)	D2	0.75	2.10	05
A (RESIDENTIAL)	D1	0.90	2.10	02
A (RESIDENTIAL)	D	1.05	2.10	08

SCHEDULE OF WINDOW/VENTILATION:

BUILDING NAME	NAME	LENGTH	HEIGHT	NOS
A (RESIDENTIAL)	V	0.60	0.90	05
A (RESIDENTIAL)	W	1.52	1.20	10

UnitBUA Table for Building :A (RESIDENTIAL)

FLOOR	Name	UnitBUA Type	UnitBUA Area	Carpet Area	No. of Rooms	No. of Tenement
GROUND FLOOR PLAN	SPLIT a	FLAT	215.21	213.82	1	1
FIRST FLOOR PLAN	SPLIT a	FLAT	0.00	0.00	7	0
SECOND FLOOR PLAN	SPLIT a	FLAT	0.00	0.00	7	0
Total:	-	-	215.21	213.82	15	1

LTP NAME AND SIGNATURE	STRUCTURAL ENG'S NAME AND SIGNATURE	BUILDER NAME AND SIGNATURE	DIGITAL SIGNATURE
KIRAN KUMARI JNP/ENG/0001/2019			