

Proposal Basic Information

Proposal File No.	JNP/BP/0003/W01/2021
Owner Name	AMIT KUMAR YADAV
Khata No	476 , 944
Plot No	3988, 3999
Village Name	Tilaiya
Use	Residential
SubUse	Bungalow/ Dwelling / Non Apartment

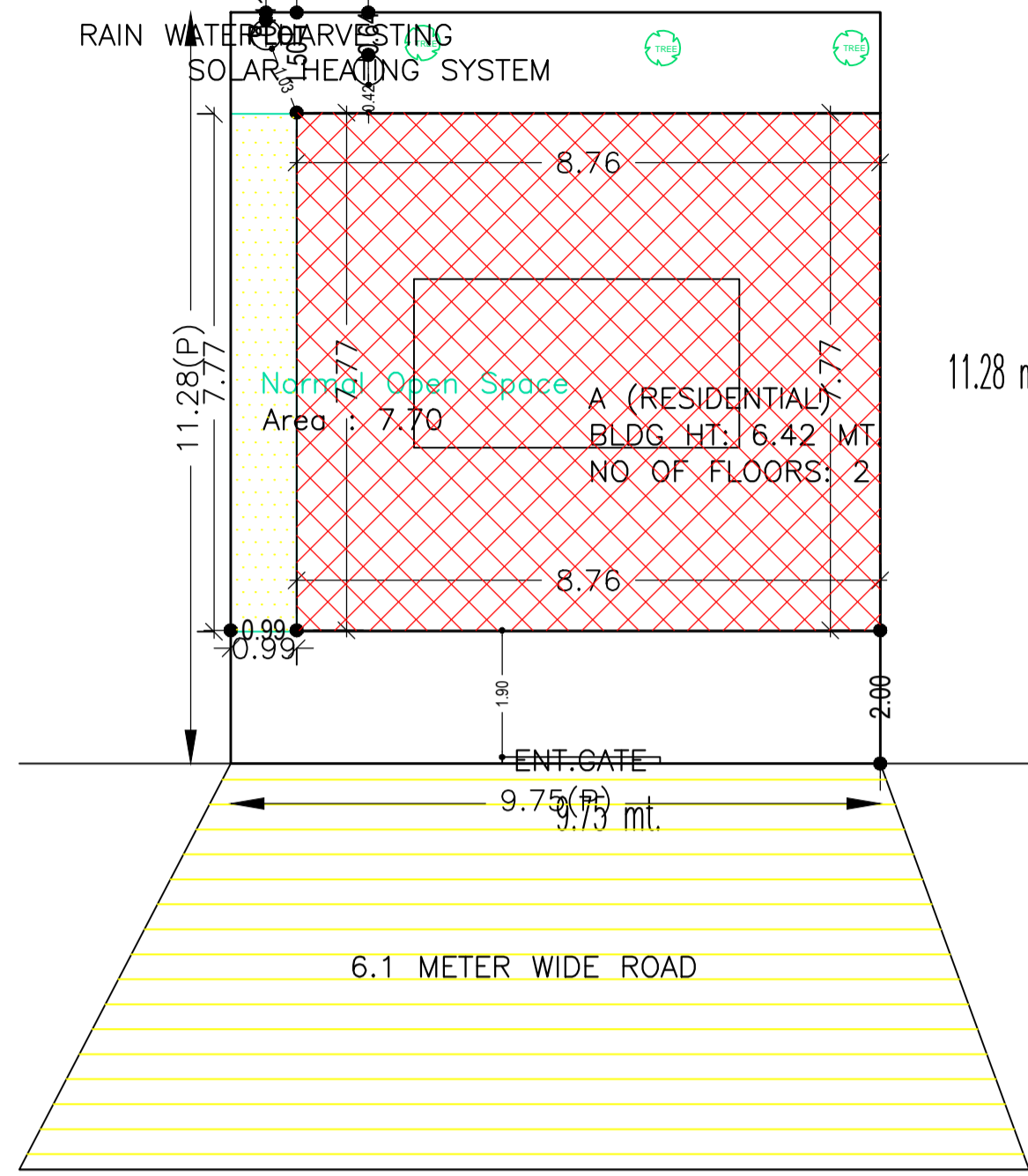

SITE PLAN

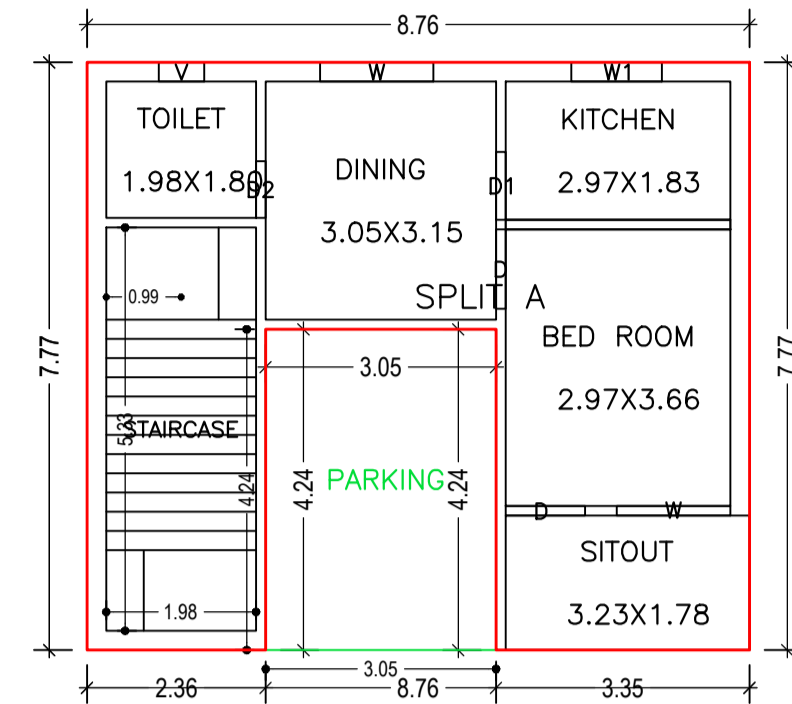

GROUND FLOOR PLAN (Proposed) (SCALE 1:100)

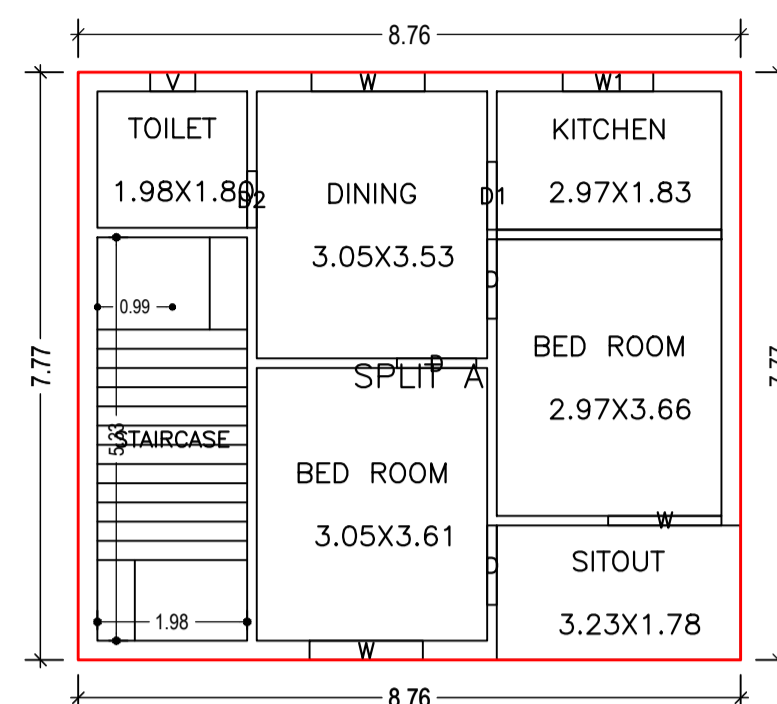

FIRST FLOOR PLAN (Proposed) (SCALE 1:100)

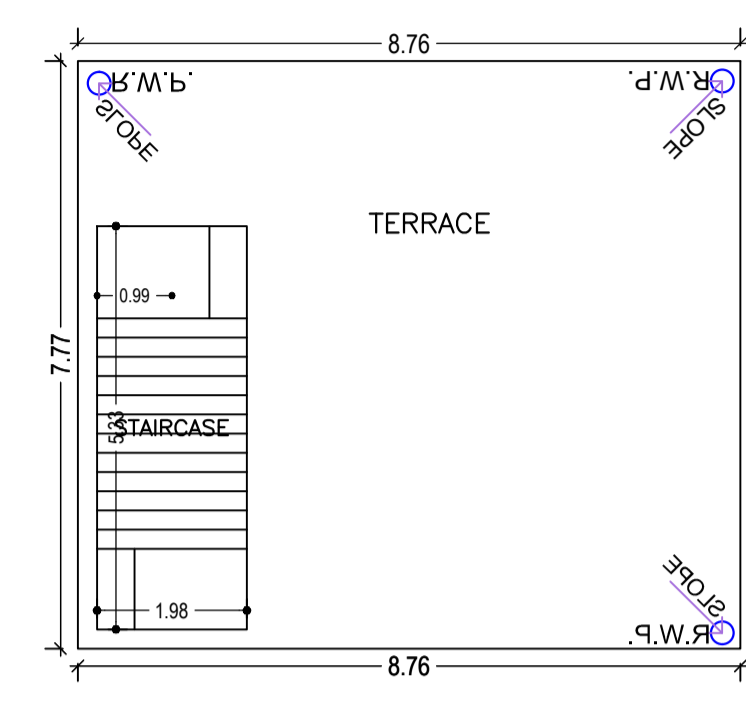

TERRACE FLOOR PLAN (SCALE 1:100)

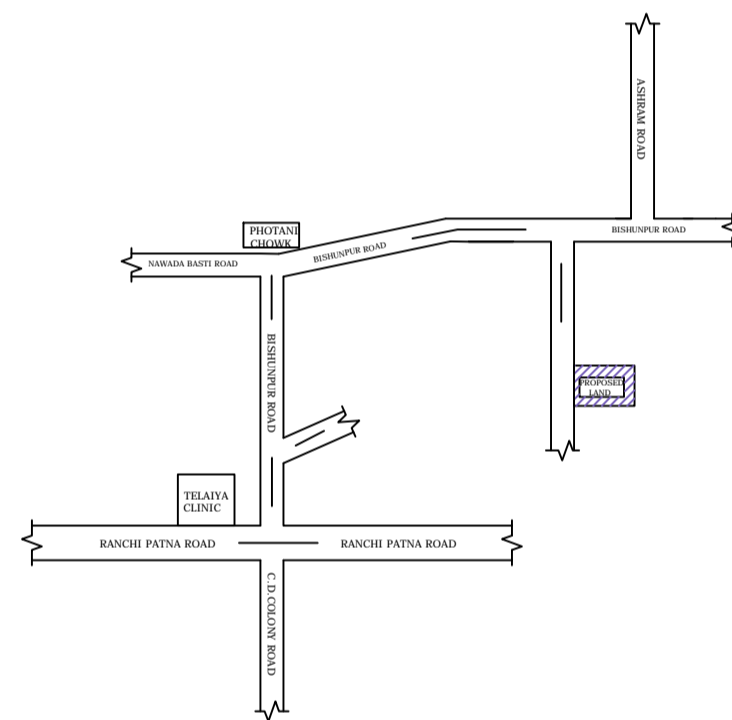

LOCATION PLAN (SCALE -1''16')

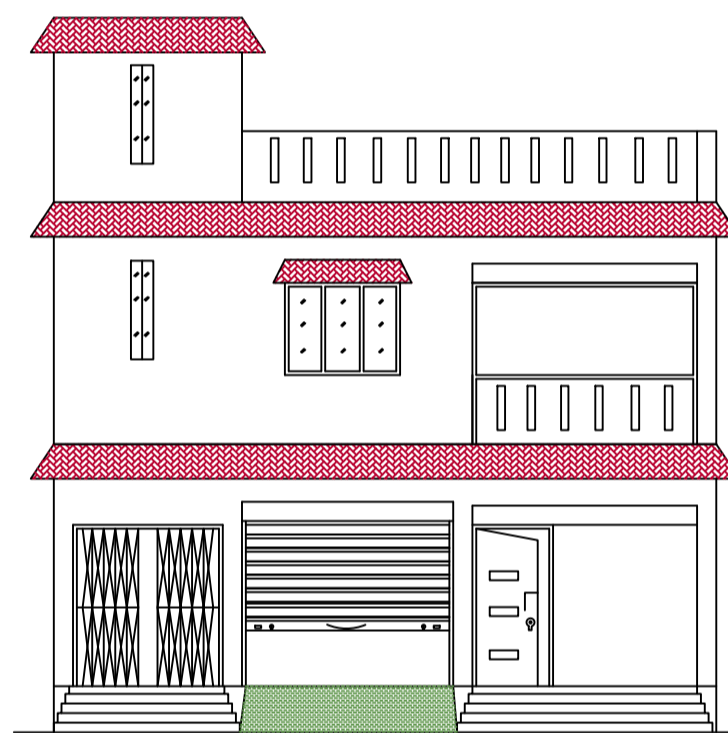

FRONT ELEVATION

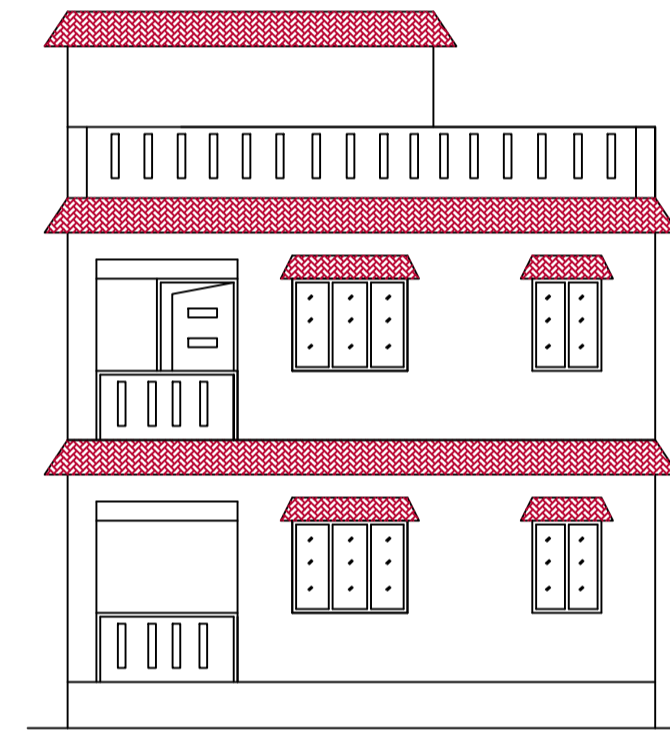

CROSS ELEVATION

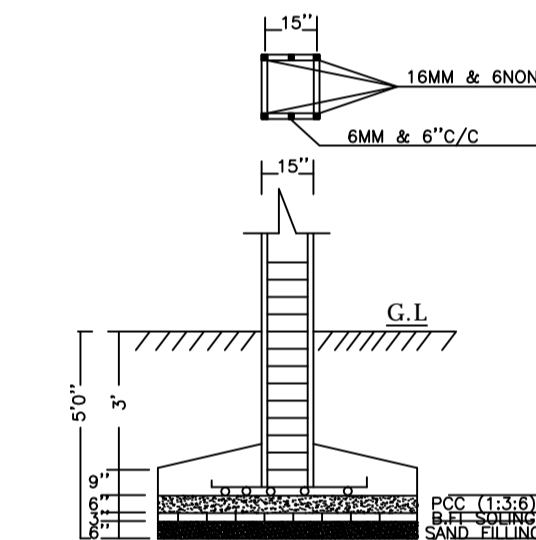

SECTION

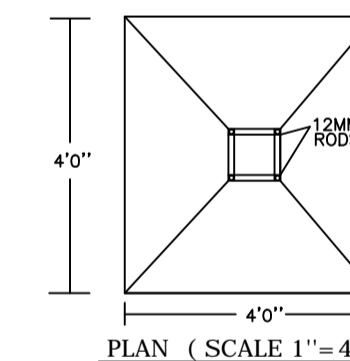

PLAN (SCALE 1''=4')

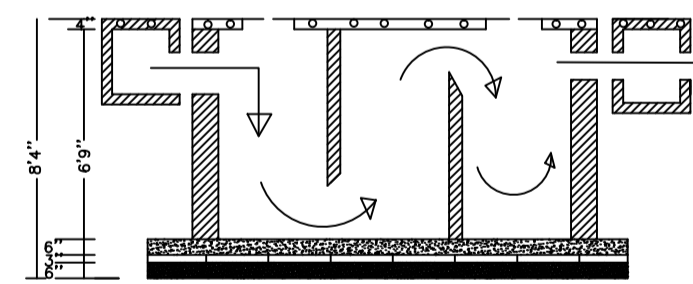

SECTION

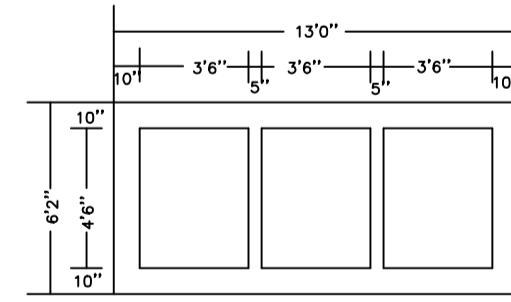

PLAN OF SEPTIC TANK

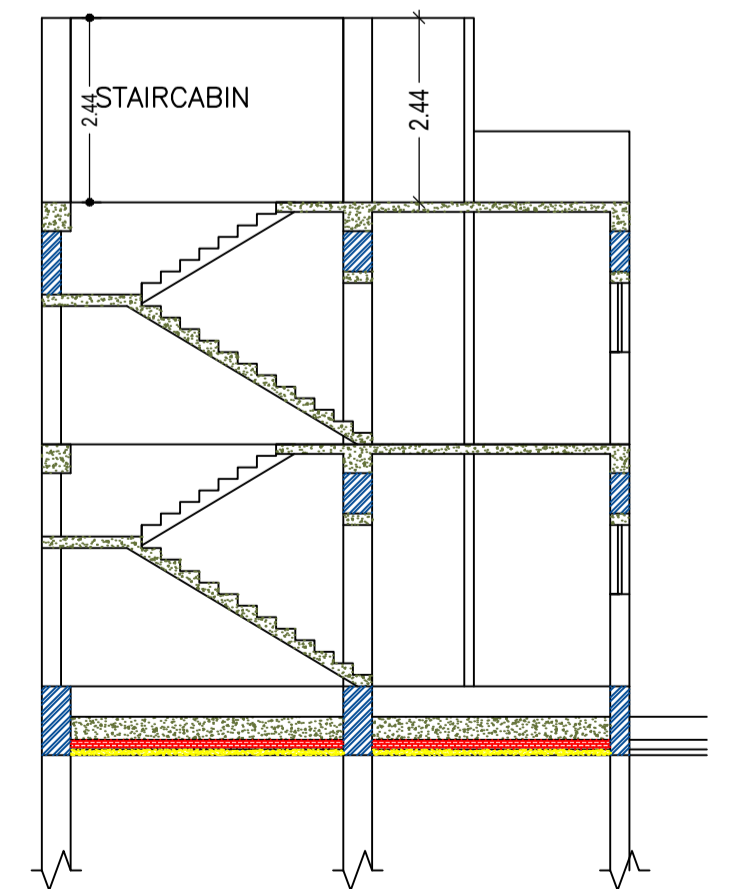

CROSS SECTION (A)

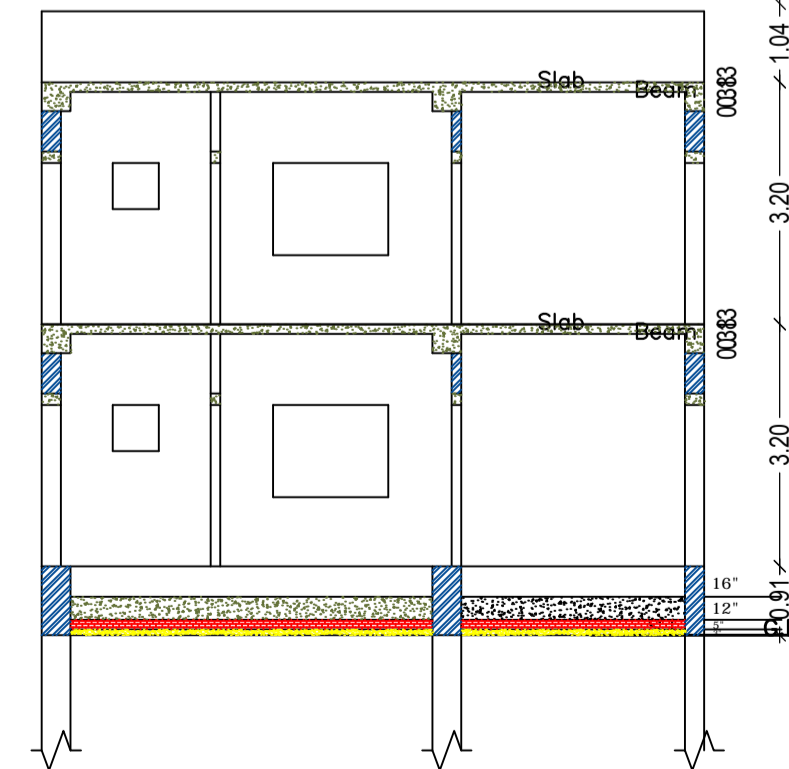

CROSS SECTION (B)

SCHEDULE OF DOOR:

BUILDING NAME	NAME	LENGTH	HEIGHT	NOS
A (RESIDENTIAL)	D2	0.75	2.10	02
A (RESIDENTIAL)	D1	0.90	2.10	02
A (RESIDENTIAL)	D	1.05	2.10	05

SCHEDULE OF WINDOW/VENTILATION:

BUILDING NAME	NAME	LENGTH	HEIGHT	NOS
A (RESIDENTIAL)	V	0.60	0.75	02
A (RESIDENTIAL)	W1	1.20	1.20	02
A (RESIDENTIAL)	W	1.50	1.20	05

Building USE/SUBUSE Details

Building Name	Building Use	Building SubUse	Building Structure
A (RESIDENTIAL)	Residential	Bungalow/ Dwelling / Non Apartment	Non-Highrise

COLOR INDEX

PLOT BOUNDARY	Black
ABUTTING ROAD	Green
PROPOSED CONSTRUCTION	Red
COMMON PLOT	Yellow
ROAD WIDENING AREA	Blue
EXISTING (To be retained)	Light Blue
EXISTING (To be demolished)	Dark Blue

AREA STATEMENT		VERSION NO. : 1.0.53
JHUMRITILAIYA NAGAR PARISHAD		VERSION DATE: 16/10/2020
PROJECT DETAIL:		
Region: JHARKHAND URBAN LOCAL BODIES	Plot Use: Residential	
District: KODERMA	Plot SubUse: Bungalow/ Dwelling / Non Apartment	
Authority: JHUMRITILAIYA NAGAR PARISHAD	PlotNearby/ReligiousStructure: NA	
Inward No: JNP/BP/0003/W01/2021	Plot/SubPlot No: 3988, 3999	
Application Type: General Proposal	North: Plot No. - TODAY SOLD VISHAL KUMAR YADAV	
Project Type: Building Permission	South: Road Width - 6.1	
Nature of Development: New	East: Plot No. - MADHUSUDAN DARUKA	
Location of Development Area: Old Area	West: Plot No. - HOUSE OF SEEMA KUMARI	
AREA DETAILS:		
AREA OF PLOT (Minimum)	(A)	SQ.MT. 110.00
NET AREA OF PLOT(Gross Plot Area - Deduction from Gross Plot area)	(A-Deductions)	110.00
Deduction for Balance Plot Area:(from Gross Plot Area)		
Common Plot		7.70
Total		7.70
BALANCE AREA OF PLOT(Net Plot Area - Recreational/Amenity space)	(A-Deductions)	102.30
PLOT AREA FOR COVERAGE(Net Plot Area)	(A-Deductions)	110.00
Plot Area for FAR (Net Plot Area + Road/Widening Area)	(A-Deductions)	110.00
COVERAGE CHECK		
Permissible Coverage area (70.00 %)		77.00
Proposed Coverage Area (61.92 %)		68.11
Total Prop. Coverage Area (61.92 %)		68.11
Balance coverage area (8.08 %)		8.89
FAR CHECK		
Perm. FAR Area (2.00)		220.00
Total Perm. FAR area		123.29
Residential FAR		123.29
Proposed FAR Area		123.29
Total Proposed FAR Area		1.12
Consumed FAR (Factor)		96.71
Balance FAR Area		136.22
BUILT UP AREA CHECK		
Total Proposed BuiltUp Area		136.22
ARCHITECT (Regd)	KIRAN KUMARI	
ENGINEER (Regd)		
SUPERVISOR (Regd)		
OWNER (Regd)	AMIT KUMAR YADAV	
DEVELOPMENT AUTHORITY		LOCAL BODY

Buildingwise Floor FAR Details

Floor Name	Building Name A (RESIDENTIAL)		Total	
	Proposed Built Up Area (Sq.mt.)	Proposed FAR Area (Sq.mt.)	Total Proposed Built Up Area (Sq.mt.)	Total FAR Area (Sq.mt.)
Ground Floor	68.11	55.18	68.11	55.18
First Floor	68.11	68.11	68.11	68.11
Terrace Floor	0.00	0.00	0.00	0.00
Total :	136.22	123.29	136.22	123.29

UnitBUA Table for Building :A (RESIDENTIAL)

FLOOR	Name	UnitBUA Type	UnitBUA Area	Carpet Area	No. of Rooms	No. of Tenement
GROUND FLOOR PLAN	SPLIT A	FLAT	86.26	85.50	5	1
FIRST FLOOR PLAN	SPLIT A	FLAT	0.00	0.00	6	0
Total:	-	-	86.26	85.50	11	1

Building :A (RESIDENTIAL)

Floor Name	Total Built Up Area (Sq.mt.)	Deductions (Area in Sq.mt.)	Proposed FAR Area (Sq.mt.)	Total FAR Area (Sq.mt.)	Total Consumed Additional FAR Area (Sq.mt.)	Tnmt (No.)
Ground Floor	68.11	12.93	55.18	55.18	55.18	01
First Floor	68.11	0.00	68.11	68.11	68.11	00
Terrace Floor	0.00	0.00	0.00	0.00	0.00	00
Total :	136.22	12.93	123.29	123.29	123.29	01
Total Number of Same Buildings :	1					
Total :	136.22	12.93	123.29	123.29	123.29	01

FAR & Tenement Details (Table 4c-1)

Building	No. of Same Bldg	Total Built Up Area (Sq.mt.)	Deductions (Area in Sq.mt.)		Proposed FAR Area (Sq.mt.)	Total FAR Area (Sq.mt.)	Total Consumed Additional FAR Area (Sq.mt.)	Tnmt (No.)
			Parking	Resi.				
A (RESIDENTIAL)	1	136.22	12.93		123.29	123.29	123.29	01
Grand Total :	1	136.22	12.93		123.29	123.29	123.29	01

LTP NAME AND SIGNATURE	STRUCTURAL ENG'S NAME AND SIGNATURE	BUILDER NAME AND SIGNATURE	DIGITAL SIGNATURE
KIRAN KUMARI JNP/ENG/001/2019			