

TERRACE FLOOR PLAN (SCALE 1:100)

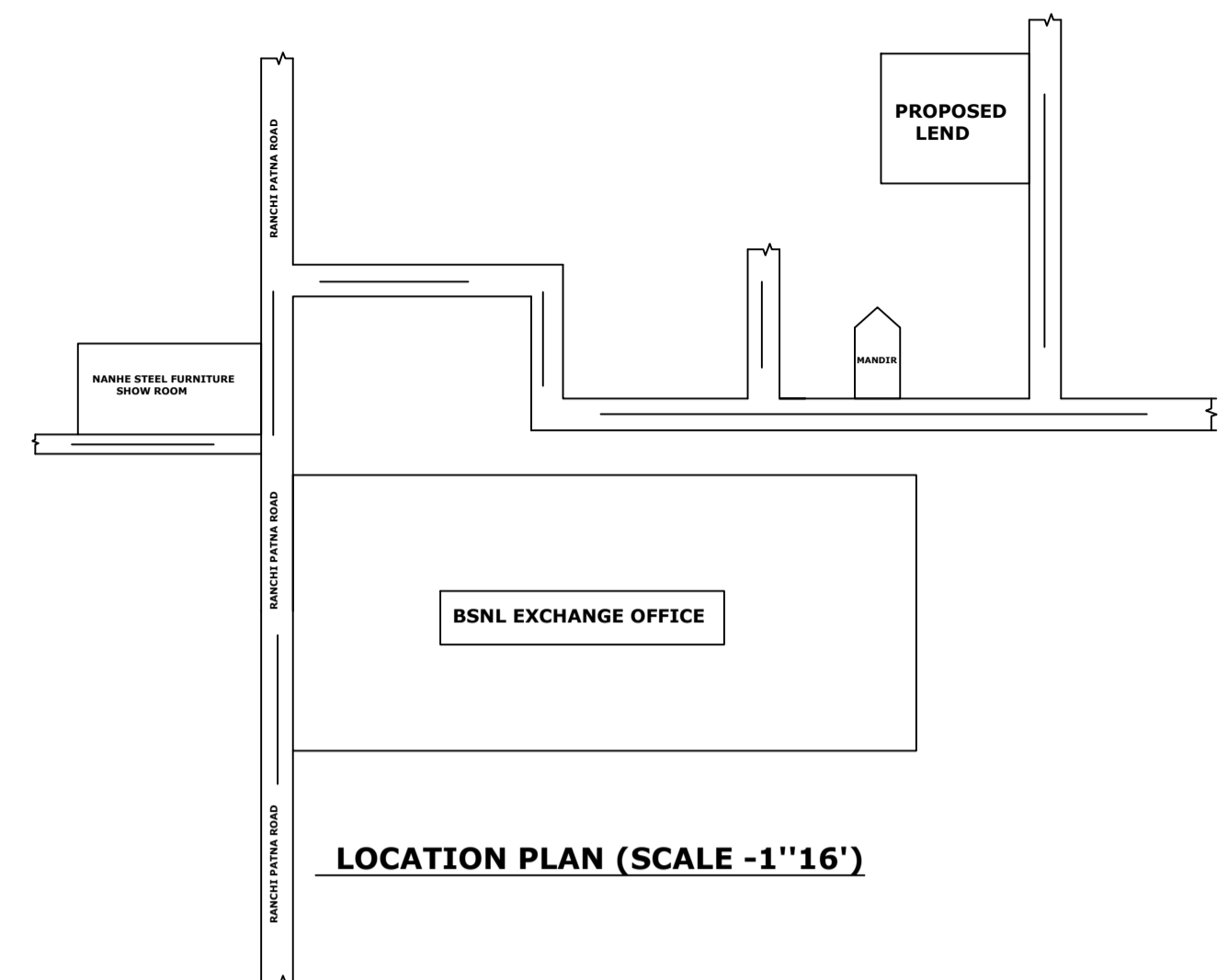

LOCATION PLAN (SCALE -1''=16'')

FAR & Tenement Details (Table 4c-1)

Building	No. of Same Bldg	Total Built Up Area (Sq.mt.)	Proposed FAR Area (Sq.mt.) Resi.	Total FAR Area (Sq.mt.)	Total Consumed Additional FAR Area (Sq.mt.)	Tnmt (No.)
A (RESIDENTIAL)	1	154.11	154.11	154.11	154.11	01
Grand Total :	1	154.11	154.11	154.11	154.11	01

Proposal Basic Information

Proposal File No.	JNP/IBP/0059/W24/2021
Owner Name	SMT PUSHPA RANI
Khata No	330
Plot No	5755
Village Name	Gomo
Use	Residential
SubUse	Bungalow/ Dwelling / Non Apartment

AREA STATEMENT

Region: JHARKHAND URBAN LOCAL BODIES	Plot Use: Residential
District: KODERMA	Plot SubUse: Bungalow/ Dwelling / Non Apartment
Authority: JHUMRITILAIYA NAGAR PARISHAD	PlotNearbyReligiousStructure: NA
Inward No: JNP/IBP/0059/W24/2021	PlotSubPlot No: 5755
Application Type: General Proposal	North: Plot No. - LAND OF DEVANAND PANDEY
Project Type: Building Permission	South: Road Width - 4.26
Nature of Development: New	East: Plot No. - LAND OF SMT INDU DEVI
Location of Development Area: Old Area	West: Plot No. - HOUSE OF BAIDNATH PR. GUPTA

AREA DETAILS:

AREA OF PLOT (Minimum)	(A)	SQ.MT.
NET AREA OF PLOT(Gross Plot Area - Deduction from Gross Plot area)	(A-Deductions)	130.06
Deduction for Balance Plot Area(from Gross Plot Area)		
Common Plot		13.12
Total		13.12
BALANCE AREA OF PLOT(Net Plot Area - Recreational/Amenity space)	(A-Deductions)	116.94
PLOT AREA FOR COVERAGE(Net Plot Area)	(A-Deductions)	130.06
Plot Area for FAR (Net Plot Area + RoadWidening Area)	(A-Deductions)	130.06

COVERAGE CHECK

Permissible Coverage area (70.00 %)	91.04
Proposed Coverage Area (59.23 %)	77.03
Total Prop. Coverage Area (59.23 %)	77.03
Balance coverage area (10.77 %)	14.01

FAR CHECK

Perm. FAR Area (1.50)	195.09
Total Perm. FAR area	195.09
Residential FAR	154.11
Proposed FAR Area	154.11
Total Proposed FAR Area	154.11
Consumed FAR (Factor)	1.18
Balance FAR Area	40.98

BUILT UP AREA CHECK

Total Proposed BuiltUp Area	154.11
-----------------------------	--------

ARCHITECT (Regd) KIRAN KUMARI
ENGINEER (Regd)
SUPERVISOR (Regd)
OWNER (Regd) SMT PUSHPA RANI

DEVELOPMENT AUTHORITY LOCAL BODY

COLOR INDEX

PLOT BOUNDARY	Black
ABUTTING ROAD	Green
PROPOSED CONSTRUCTION	Red
COMMON PLOT	Yellow
ROAD WIDENING AREA	Blue
EXISTING (To be retained)	Light Blue
EXISTING (To be demolished)	White

SITE PLAN

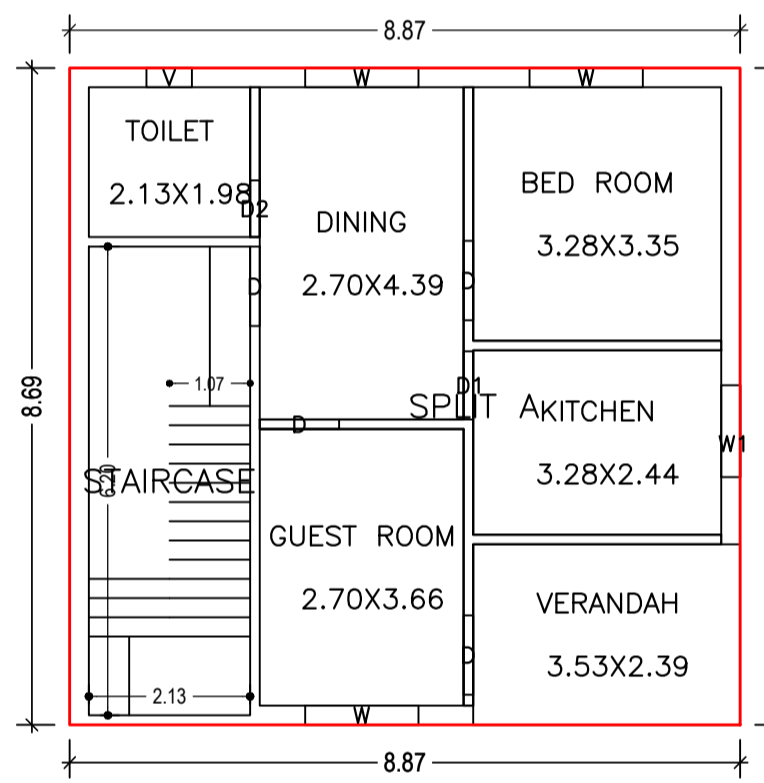

GROUND FLOOR PLAN (Proposed) (SCALE 1:100)

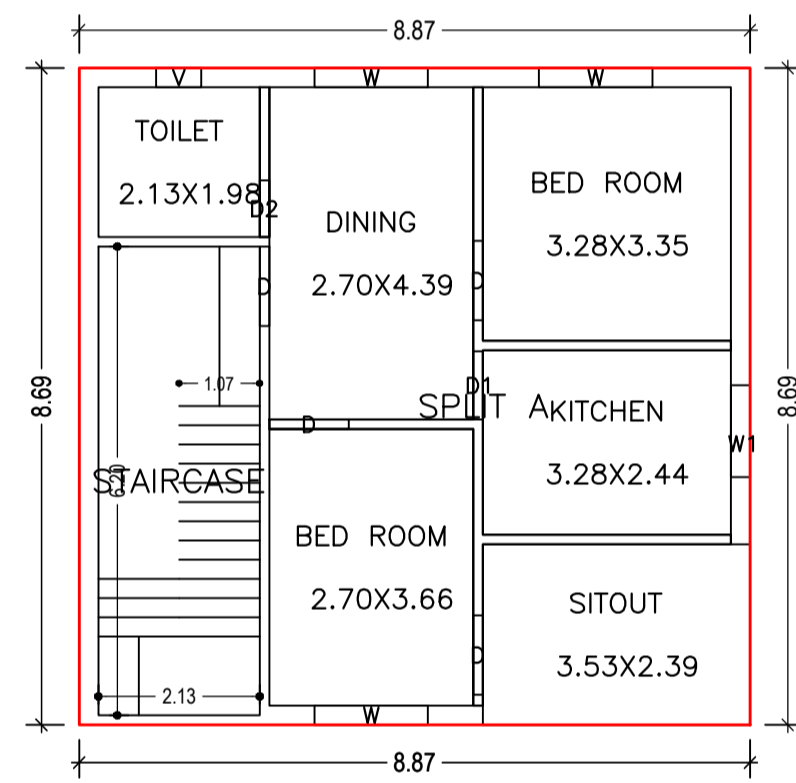

FIRST FLOOR PLAN (Proposed) (SCALE 1:100)

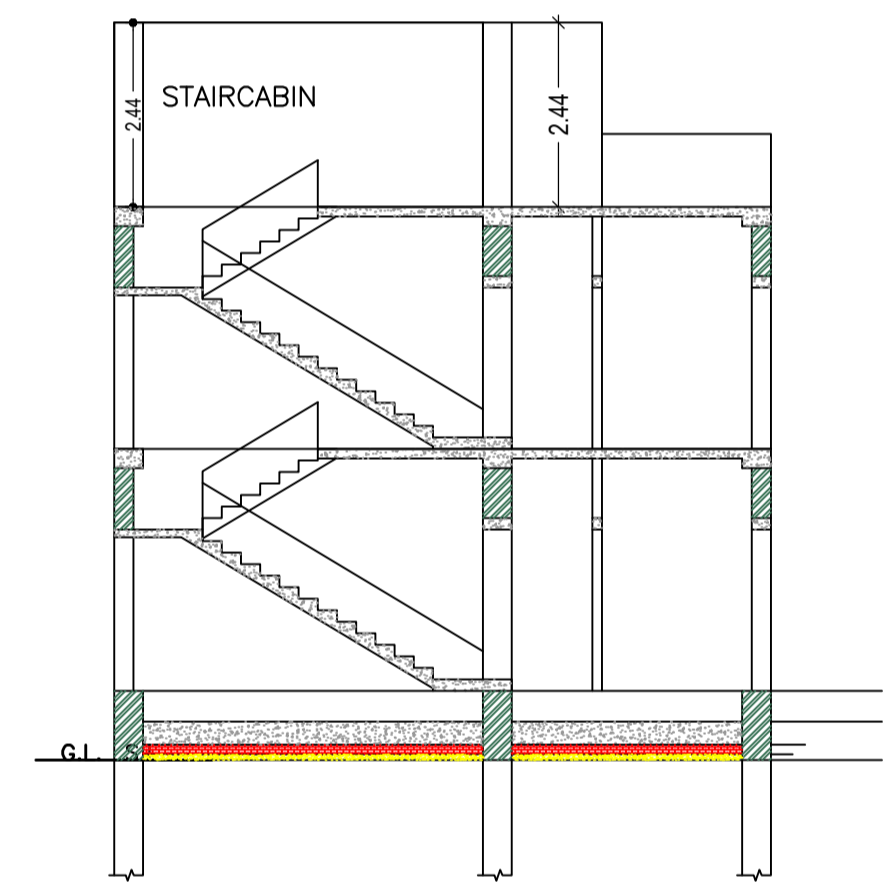

CROSS SECTION (A)

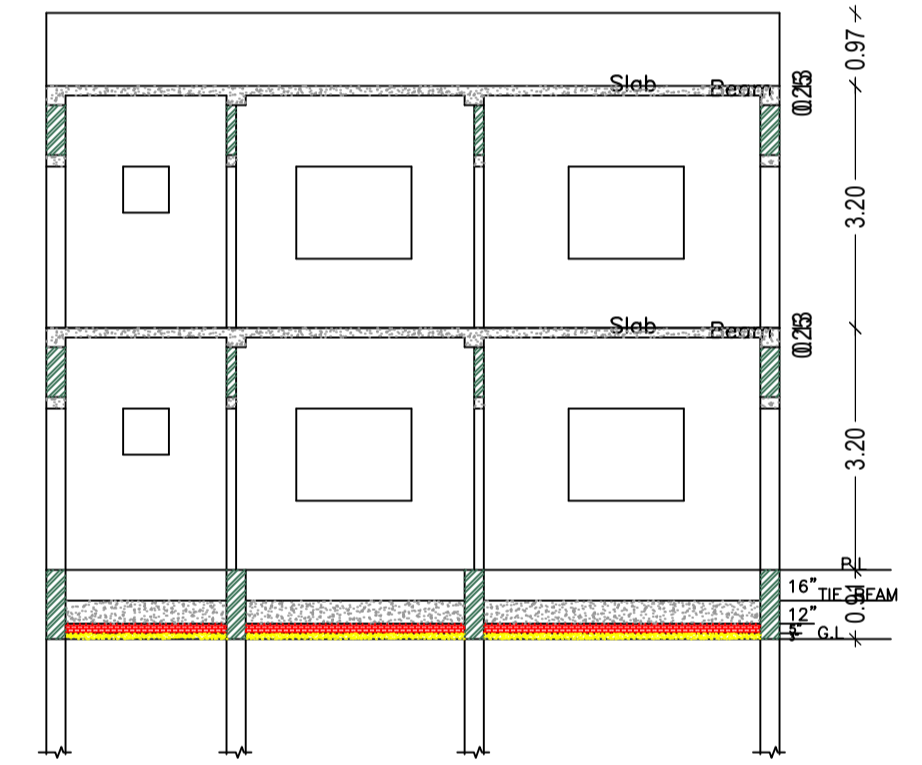

CROSS SECTION (B)

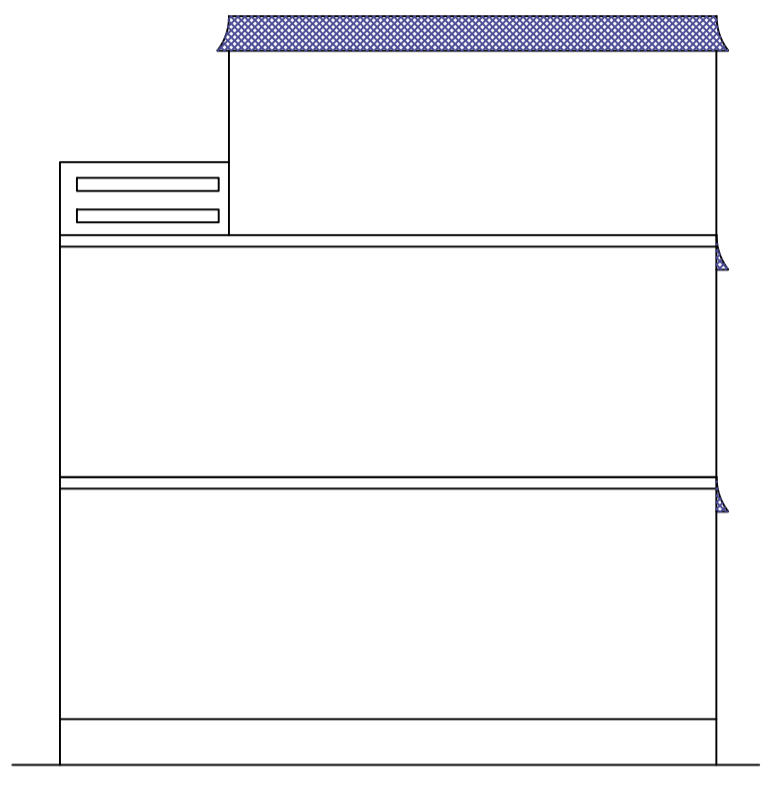

CROSS ELEVATION

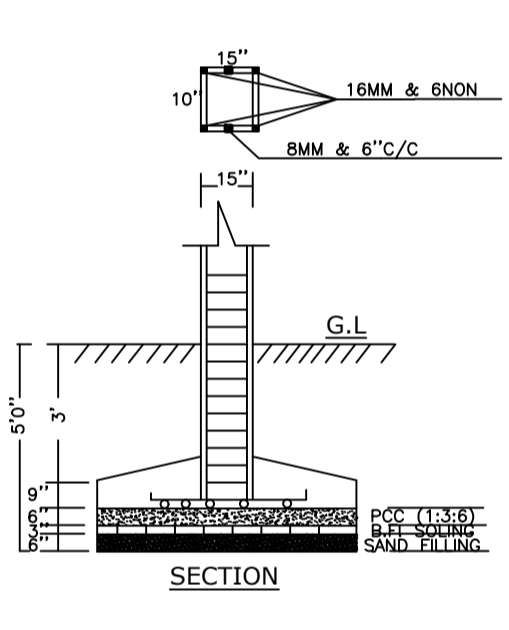

SECTION

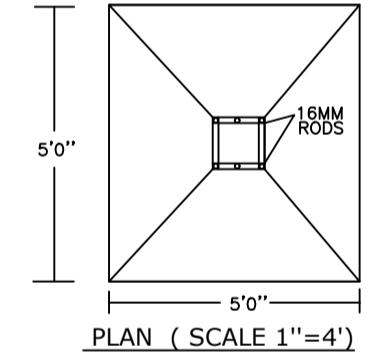

PLAN (SCALE 1''=4')

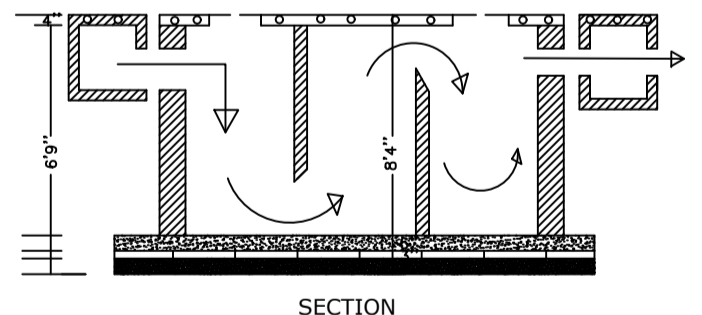

SECTION

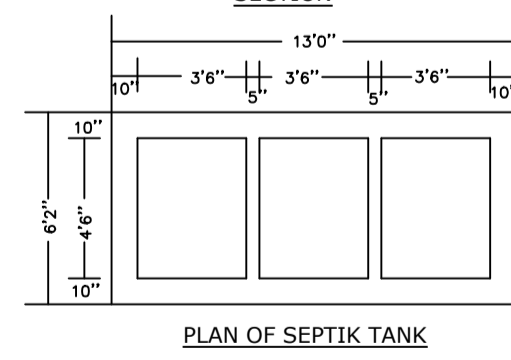

PLAN OF SEPTIC TANK

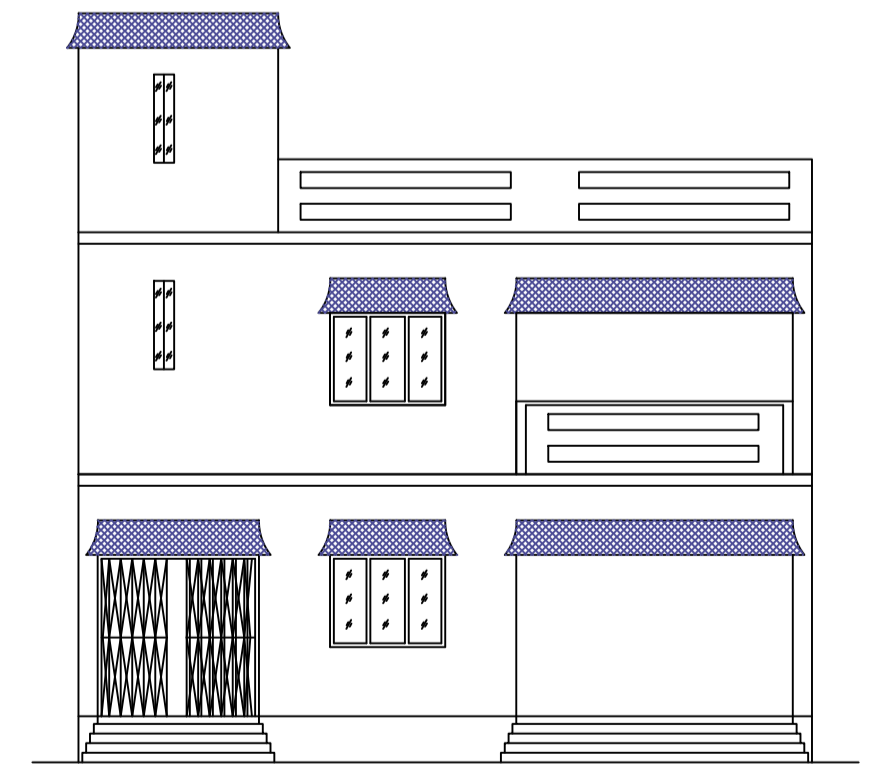

FRONT ELEVATION

Building :A (RESIDENTIAL)

Floor Name	Total Built Up Area (Sq.mt.)	Proposed FAR Area (Sq.mt.) Resi.	Total FAR Area (Sq.mt.)	Total Consumed Additional FAR Area (Sq.mt.)	Tnmt (No.)
Ground Floor	77.03	77.03	77.03	77.03	01
First Floor	77.08	77.08	77.08	77.08	00
Terrace Floor	0.00	0.00	0.00	0.00	00
Total :	154.11	154.11	154.11	154.11	01
Total Number of Same Buildings	1				
Total :	154.11	154.11	154.11	154.11	01

SCHEDULE OF DOOR:

BUILDING NAME	NAME	LENGTH	HEIGHT	NOS
A (RESIDENTIAL)	D2	0.75	2.10	02
A (RESIDENTIAL)	D1	0.90	2.10	02
A (RESIDENTIAL)	D	1.05	2.10	08

SCHEDULE OF WINDOW/VENTILATION:

BUILDING NAME	NAME	LENGTH	HEIGHT	NOS
A (RESIDENTIAL)	V	0.60	0.90	02
A (RESIDENTIAL)	W1	1.21	1.20	02
A (RESIDENTIAL)	W	1.50	1.20	06

UnitBUA Table for Building :A (RESIDENTIAL)

FLOOR	Name	UnitBUA Type	UnitBUA Area	Carpet Area	No. of Rooms	No. of Tenement
GROUND FLOOR PLAN	SPLIT A	FLAT	111.68	106.74	6	1
FIRST FLOOR PLAN	SPLIT A	FLAT	0.00	0.00	6	0
Total:	-	-	111.68	106.74	12	1

Buildingwise Floor FAR Details

Floor Name	Building Name A (RESIDENTIAL)		Total	
	Proposed Built Up Area (Sq.mt.)	Proposed FAR Area (Sq.mt.)	Total Proposed Built Up Area (Sq.mt.)	Total FAR Area (Sq.mt.)
Ground Floor	77.03	77.03	77.03	77.03
First Floor	77.08	77.08	77.08	77.08
Terrace Floor	0.00	0.00	0.00	0.00
Total :	154.11	154.11	154.11	154.11

Building USE/SUBUSE Details

Building Name	Building Use	Building SubUse	Building Structure
A (RESIDENTIAL)	Residential	Bungalow/ Dwelling / Non Apartment	Non-Highrise

LTP NAME AND SIGNATURE	STRUCTURAL ENG'S NAME AND SIGNATURE	BUILDER NAME AND SIGNATURE	DIGITAL SIGNATURE
KIRAN KUMARI JNP/ENG/0001/2019			