

SITE PLAN

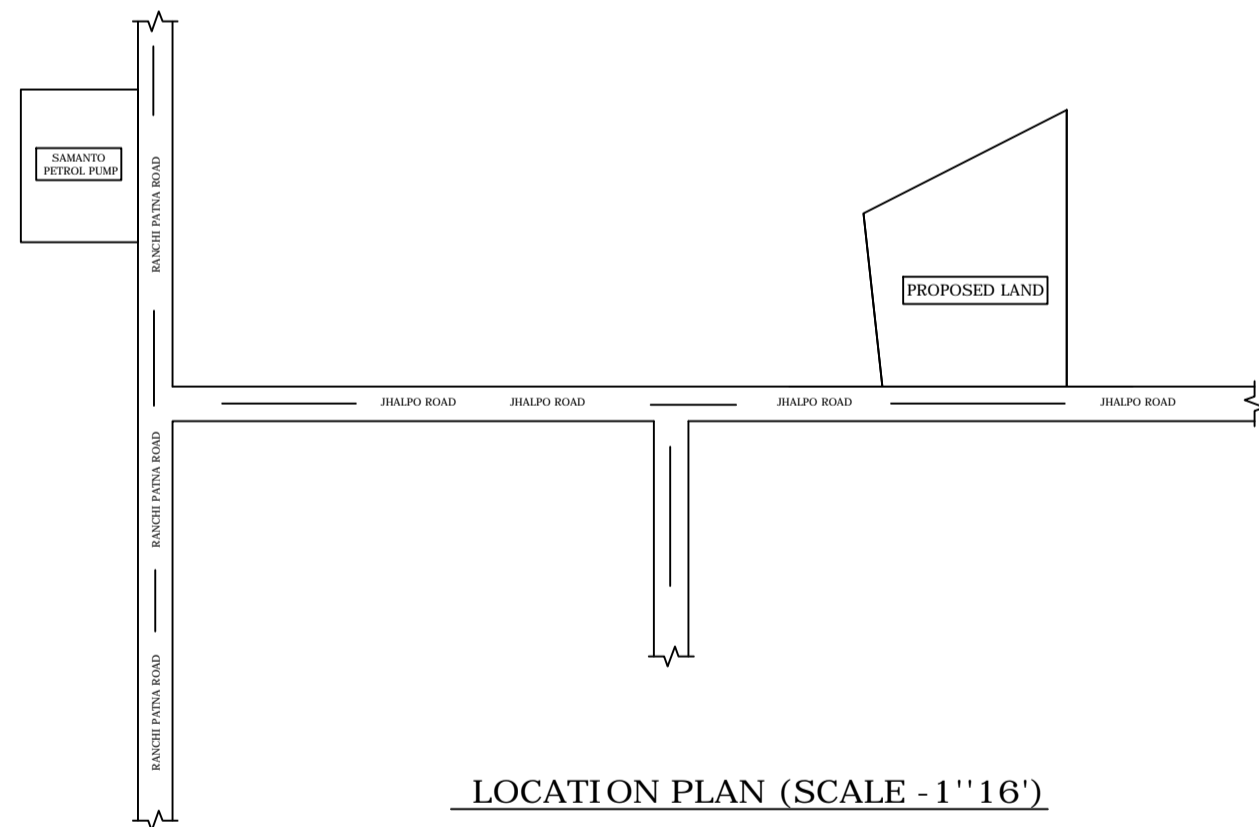

LOCATION PLAN (SCALE -1''=16'')

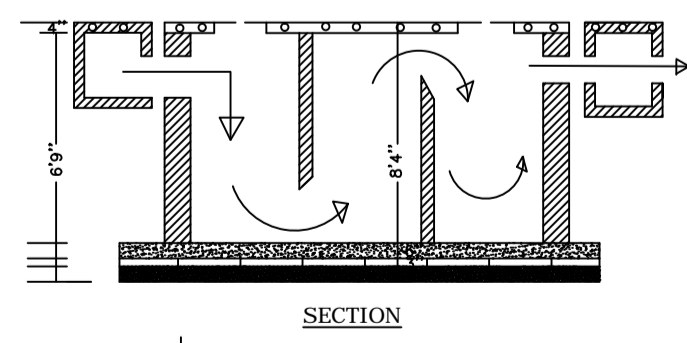

SECTION

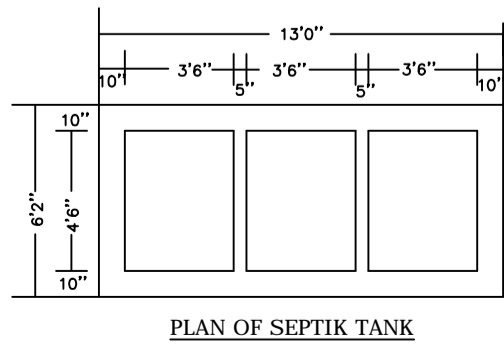

PLAN OF SEPTIK TANK

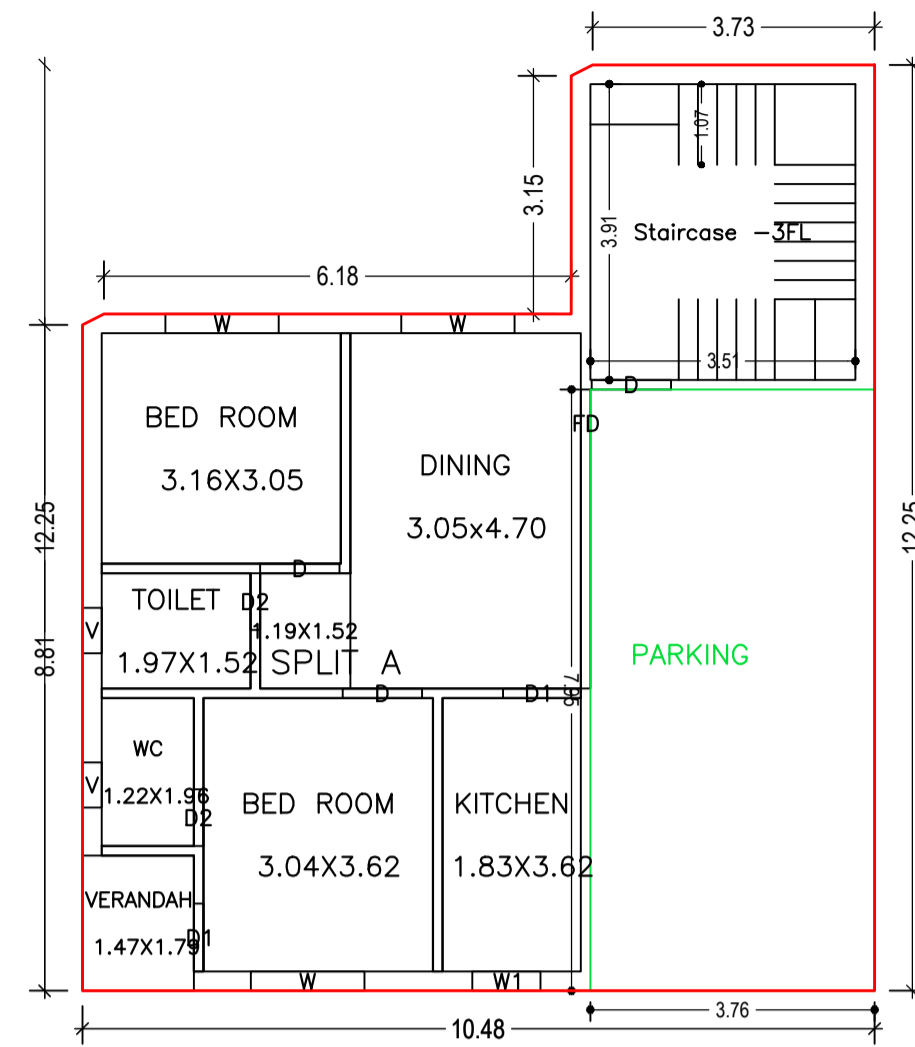

GROUND FLOOR PLAN (Proposed) (SCALE 1:100)

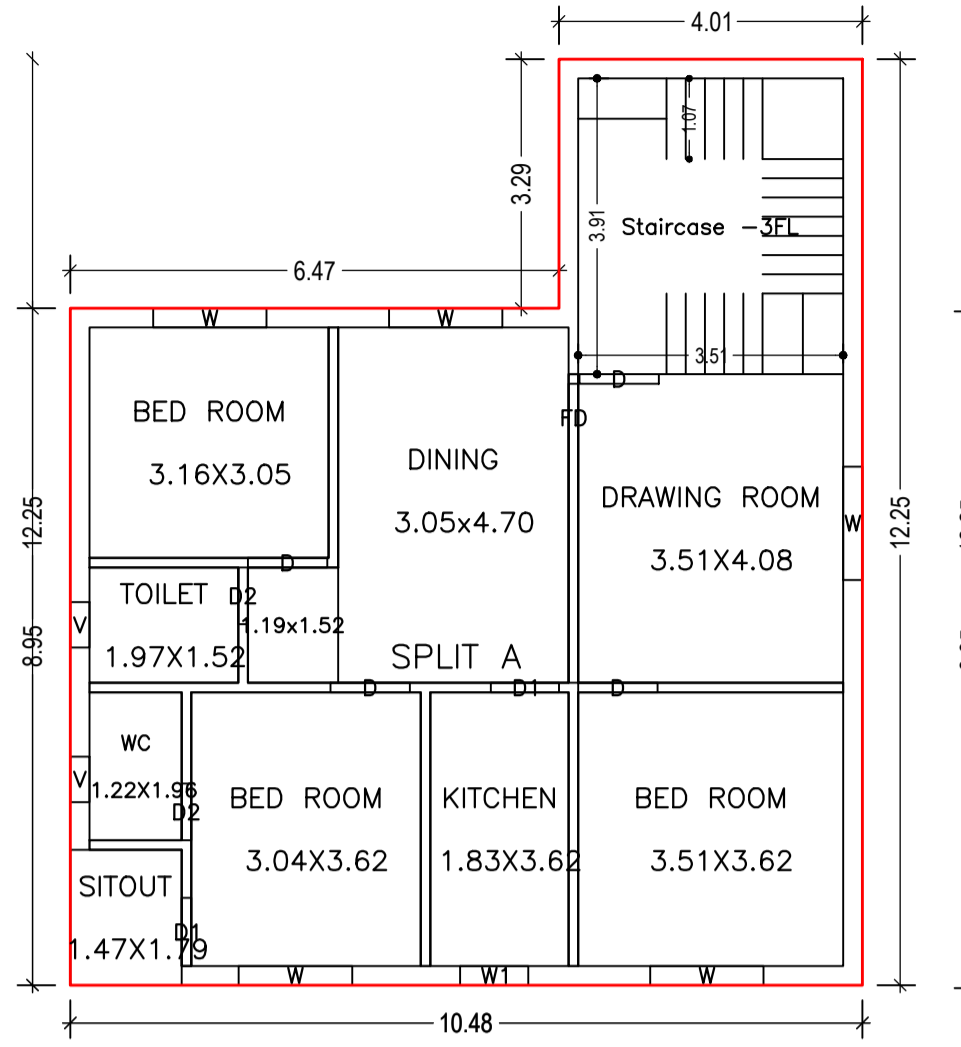

FIRST FLOOR PLAN (Proposed) (SCALE 1:100)

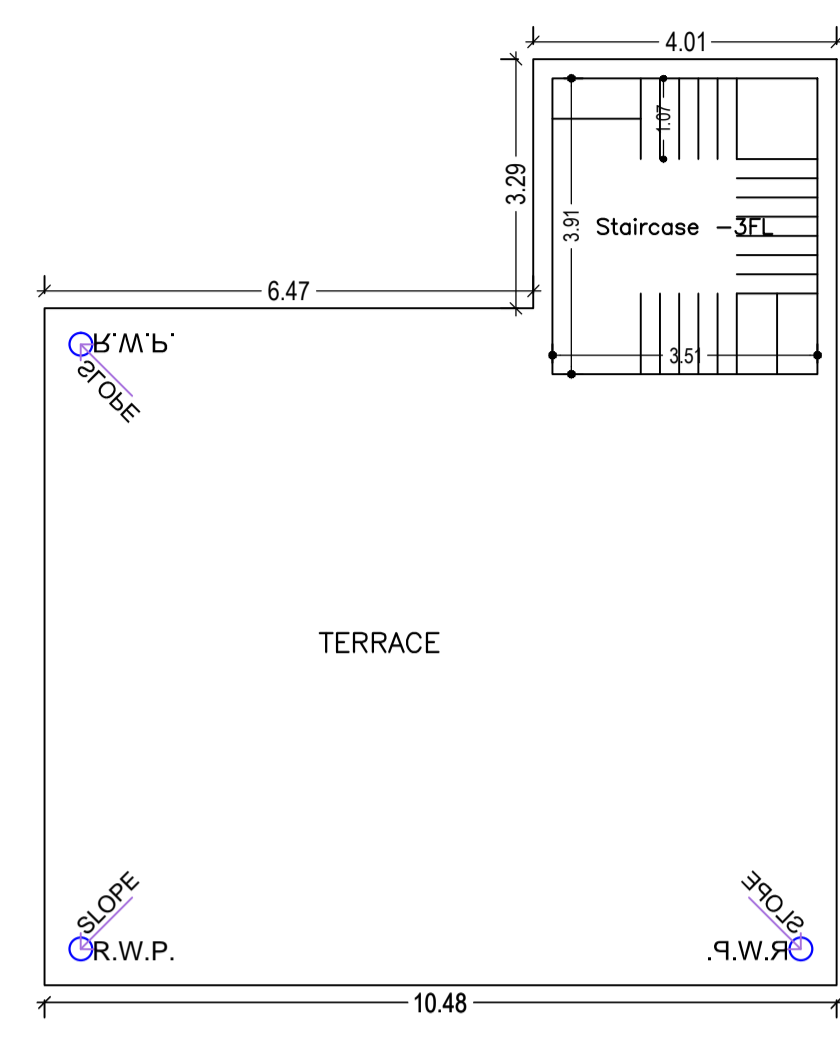

TERRACE FLOOR PLAN (SCALE 1:100)

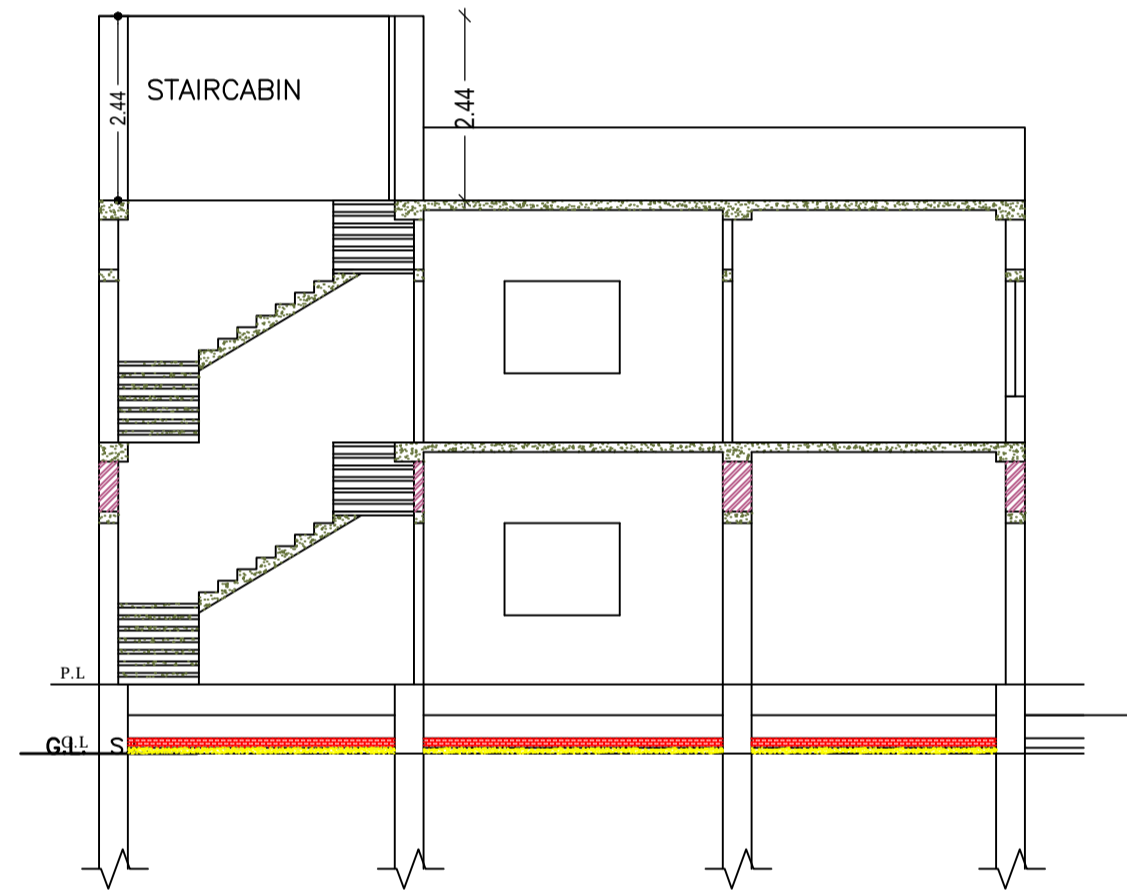

CROSS SECTION (A)

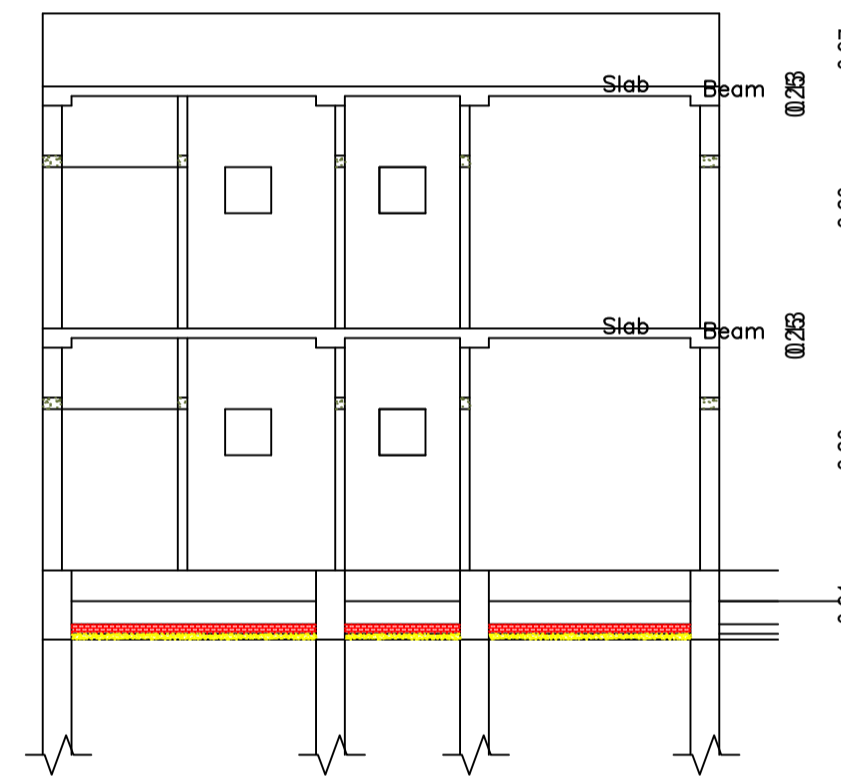

CROSS SECTION (B)

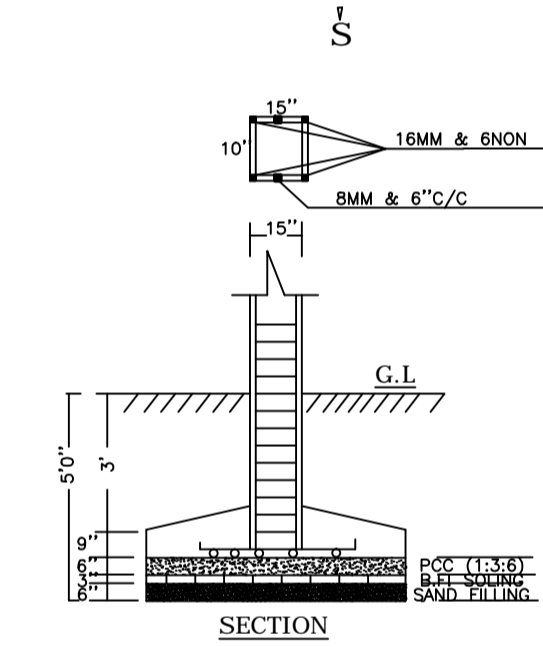

SECTION

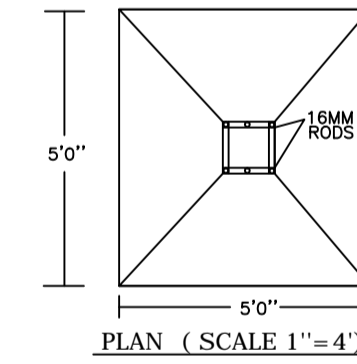

PLAN (SCALE 1''=4')

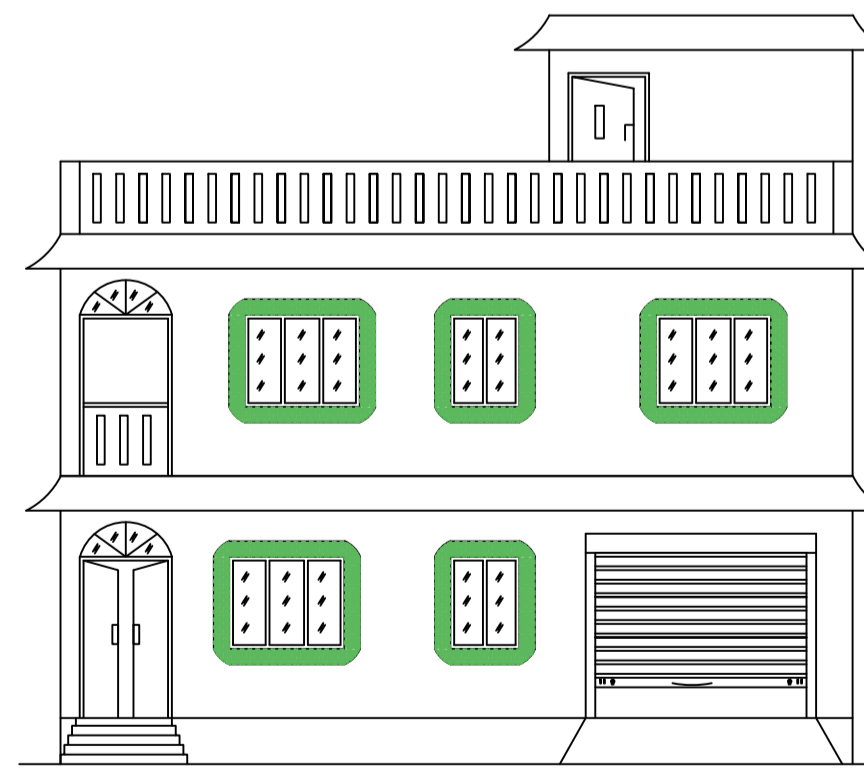

FRONT ELEVATION

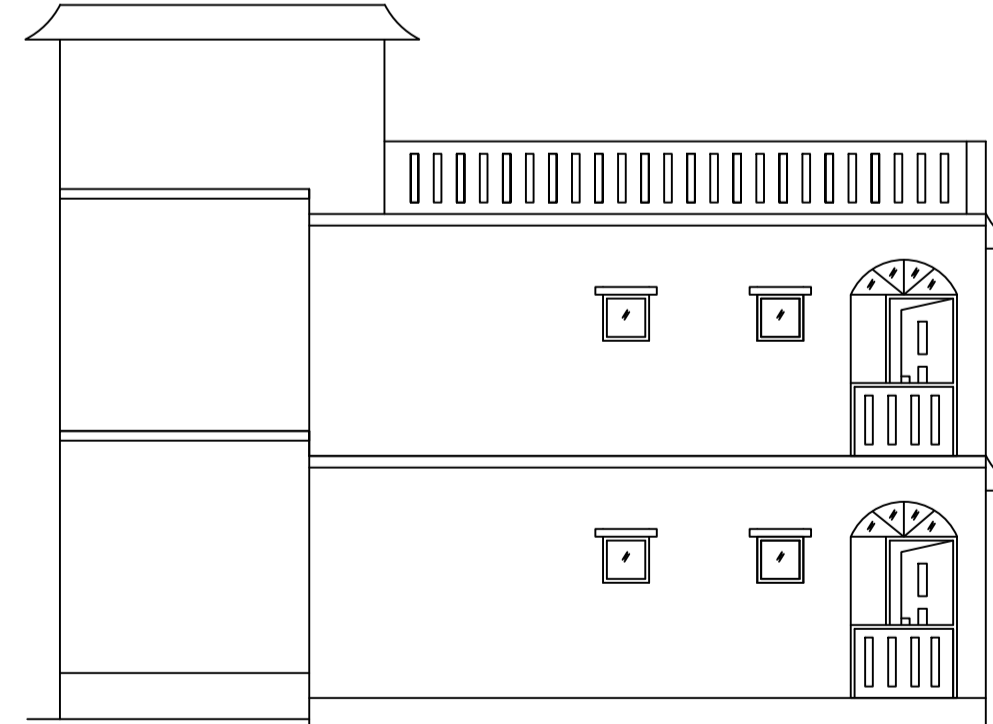

CROSS ELEVATION

UnitBUA Table for Building :A (RESIDENTIAL)

FLOOR	Name	UnitBUA Type	UnitBUA Area	Carpet Area	No. of Rooms	No. of Tenement
FIRST FLOOR PLAN	SPLIT A	FLAT	0.00	0.00	9	1
Total:	-	-	136.99	129.79	7	1

SCHEDULE OF DOOR:

BUILDING NAME	NAME	LENGTH	HEIGHT	NOS
A (RESIDENTIAL)	D2	0.75	2.10	04
A (RESIDENTIAL)	D1	0.90	2.10	01
A (RESIDENTIAL)	D	1.05	2.10	01
A (RESIDENTIAL)	FD	3.95	2.10	02

SCHEDULE OF WINDOW/VENTILATION:

BUILDING NAME	NAME	LENGTH	HEIGHT	NOS
A (RESIDENTIAL)	V	0.60	0.75	04
A (RESIDENTIAL)	W1	0.90	1.20	02
A (RESIDENTIAL)	W	1.50	1.20	08

COLOR INDEX

PLOT BOUNDARY	Black
ABUTTING ROAD	Green
PROPOSED CONSTRUCTION	Red
COMMON PLOT	Yellow
ROAD WIDENING AREA	Blue
EXISTING (To be retained)	Light Blue
EXISTING (To be demolished)	Dark Blue

LTP NAME AND SIGNATURE

KIRAN KUMARI  
JNP/ENG/001/2019

STRUCTURAL ENG'S NAME AND SIGNATURE

BUILDER NAME AND SIGNATURE

DIGITAL SIGNATURE

Proposal Basic Information

Proposal File No.	JNP/BI/0054/W09/2021
Owner Name	SRI MAHABIR YADAV
Khata No	168
Plot No	97
Village Name	Jhalpo
Use	Residential
SubUse	Bungalow/ Dwelling / Non Apartment

AREA STATEMENT		VERSION NO. : 1.0/57
JHUMRITILAIYA NAGAR PARISHAD		VERSION DATE: 16/10/2020
PROJECT DETAIL:		
Region: JHARKHAND URBAN LOCAL BODIES	Plot Use: Residential	
District: KODERMA	Plot SubUse: Bungalow/ Dwelling / Non Apartment	
Authority: JHUMRITILAIYA NAGAR PARISHAD	PlotNearby/ReligiousStructure: NA	
Inward_No: JNP/BI/0054/W09/2021	Plot/SubPlot No: 97	
Application Type: General Proposal	North: Plot No. - LAND OF LATE YOGENDRA SINGH	
Project Type: Building Permission	South: Road Width - 4.57	
Nature of Development: New	East: Plot No. - LAND OF SRI KAMLESH CHANDRA	
Location of Development Area: Old Area	West: Plot No. - LAND OF SRI KAMLESH CHANDRA	
AREA DETAILS:		
AREA OF PLOT (Minimum)	(A)	SQ.MT. 192.65
NET AREA OF PLOT(Gross Plot Area - Deduction from Gross Plot area)	(A-Deductions)	192.65
Deduction for Balance Plot Area(from Gross Plot Area)		
Common Plot		29.82
Total		29.82
BALANCE AREA OF PLOT(Net Plot Area - Recreational/Amenity space)	(A-Deductions)	162.83
PLOT AREA FOR COVERAGE(Net Plot Area)	(A-Deductions)	192.65
Plot Area for FAR (Net Plot Area + RoadWidening Area)	(A-Deductions)	192.65
COVERAGE CHECK		
Permissible Coverage area ( 70.00 % )		134.85
Proposed Coverage Area ( 55.53 % )		106.98
Total Prop. Coverage Area ( 55.53 % )		106.98
Balance coverage area ( 14.47 % )		27.87
FAR CHECK		
Perm. FAR Area ( 1.50 )		288.97
Total Perm. FAR area		288.97
Residential FAR		214.00
Proposed FAR Area		214.00
Total Proposed FAR Area		214.00
Consumed FAR (Factor)		1.11
Balance FAR Area		74.97
BUILT UP AREA CHECK		
Total Proposed BuiltUp Area		214.00
ARCHITECT (Regd)		
		KIRAN KUMARI
ENGINEER (Regd)		
		SRI MAHABIR YADAV
SUPERVISOR (Regd)		
		SRI MAHABIR YADAV
OWNER (Regd)		
		SRI MAHABIR YADAV
DEVELOPMENT AUTHORITY		
		LOCAL BODY

FAR & Tenement Details (Table 4c-1)

Building	No. of Same Bldg	Total Built Up Area (Sq.mt.)	Proposed FAR Area (Sq.mt.)	Total FAR Area (Sq.mt.)	Total Consumed Additional FAR Area (Sq.mt.)	Tnmt (No.)
A (RESIDENTIAL)	1	214.00	214.00	214.00	214.00	01
Grand Total :	1	214.00	214.00	214.00	214.00	01

Buildingwise Floor FAR Details

Floor Name	Building Name A (RESIDENTIAL)		Total	
	Proposed Built Up Area (Sq.mt.)	Proposed FAR Area (Sq.mt.)	Total Proposed Built Up Area (Sq.mt.)	Total FAR Area (Sq.mt.)
Ground Floor	106.98	106.98	106.98	106.98
First Floor	107.02	107.02	107.02	107.02
Terrace Floor	0.00	0.00	0.00	0.00
Total :	214.00	214.00	214.00	214.00

Building USE/SUBUSE Details

Building Name	Building Use	Building SubUse	Building Structure
A (RESIDENTIAL)	Residential	Bungalow/ Dwelling / Non Apartment	Non-Highrise

Building :A (RESIDENTIAL)

Floor Name	Total Built Up Area (Sq.mt.)	Proposed FAR Area (Sq.mt.)	Total FAR Area (Sq.mt.)	Total Consumed Additional FAR Area (Sq.mt.)	Tnmt (No.)
Ground Floor	106.98	106.98	106.98	106.98	01
First Floor	107.02	107.02	107.02	107.02	00
Terrace Floor	0.00	0.00	0.00	0.00	00
Total :	214.00	214.00	214.00	214.00	01
Total Number of Same Buildings :	1				
Total :	214.00	214.00	214.00	214.00	01