

SITE PLAN

SMT. SUMITRA DEVI SITE PLAN

FAR & Tenement Details (Table 4c-1)

Building	No. of Same Bldg	Total Built Up Area (Sq.mt.)	Proposed FAR Area (Sq.mt.) Resi.	Total FAR Area (Sq.mt.)	Total Consumed Additional FAR Area (Sq.mt.)	Tnmt (No.)
A (SUMITRA DEVI HOUSE PLAN)	1	206.64	206.64	206.64	206.64	01
Grand Total :	1	206.64	206.64	206.64	206.64	01

Proposal Basic Information

Proposal File No.	JNP/IBP/0025/W01/2021
Owner Name	SMT. SUMITRA DEVI
Khata No	06
Plot No	227
Village Name	Nawada
Use	Residential
SubUse	Bungalow/ Dwelling / Non Apartment

AREA STATEMENT	VERSION NO. : 1.0.54
JHUMRITILAIYA NAGAR PARISHAD	VERSION DATE: 16/10/2020
PROJECT DETAIL:	
Region: JHARKHAND URBAN LOCAL BODIES	Plot Use: Residential
District: KODERMA	Plot SubUse: Bungalow/ Dwelling / Non Apartment
Authority: JHUMRITILAIYA NAGAR PARISHAD	PlotNearbyReligiousStructure: NA
Inward No: JNP/IBP/0025/W01/2021	Plot/SubPlot No: 227
Application Type: General Proposal	North: Road Width - 3.65 Mtr. WIDE ROAD
Project Type: Building Permission	South: Plot No. - LAND OF SHUKAR MAHTO
Nature of Development: New	East: Plot No. - NIZ LAND OF VENDOR
Location of Development Area: Old Area	West: Plot No. - NIZ LAND OF VENDOR
AREA DETAILS:	
AREA OF PLOT (Minimum)	(A) 166.09
NET AREA OF PLOT(Gross Plot Area - Deduction from Gross Plot area)	(A-Deductions) 166.09
Deduction for Balance Plot Area(from Gross Plot Area)	
Common Plot	20.07
Total	20.07
BALANCE AREA OF PLOT(Net Plot Area - Recreational/Amenity space)	(A-Deductions) 146.02
PLOT AREA FOR COVERAGE(Net Plot Area)	(A-Deductions) 166.09
Plot Area for FAR (Net Plot Area + Road Widening Area)	(A-Deductions) 166.09
COVERAGE CHECK	
Permissible Coverage area (70.00 %)	116.26
Proposed Coverage Area (62.21 %)	103.32
Total Prop. Coverage Area (62.21 %)	103.32
Balance coverage area (7.79 %)	12.94
FAR CHECK	
Perm. FAR Area (1.50)	249.13
Total Perm. FAR area	249.13
Residential FAR	206.65
Proposed FAR Area	206.65
Total Proposed FAR Area	206.65
Consumed FAR (Factor)	1.24
Balance FAR Area	42.48
BUILT UP AREA CHECK	
Total Proposed BuiltUp Area	206.64
ARCHITECT (Regd)	UPENDRA
ENGINEER (Regd)	
SUPERVISOR (Regd)	
OWNER (Regd)	SMT. SUMITRA DEVI
DEVELOPMENT AUTHORITY	LOCAL BODY

COLOR INDEX	
PLOT BOUNDARY	Black
ABUTTING ROAD	Green
PROPOSED CONSTRUCTION	Red
COMMON PLOT	Yellow
ROAD WIDENING AREA	Blue
EXISTING (To be retained)	Blue
EXISTING (To be demolished)	Yellow

Buildingwise Floor FAR Details

Floor Name	Building Name		Total	
	Proposed Built Up Area (Sq.mt.)	Proposed FAR Area (Sq.mt.)	Total Proposed Built Up Area (Sq.mt.)	Total FAR Area (Sq.mt.)
Ground Floor	103.32	103.32	103.32	103.32
First Floor	103.32	103.32	103.32	103.32
Terrace Floor	0.00	0.00	0.00	0.00
Total :	206.64	206.64	206.64	206.64

Building USE/SUBUSE Details

Building Name	Building Use	Building SubUse	Building Structure
A (SUMITRA DEVI HOUSE PLAN)	Residential	Bungalow/ Dwelling / Non Apartment	Non-Highrise

LTP NAME AND SIGNATURE	STRUCTURAL ENG'S NAME AND SIGNATURE	BUILDER NAME AND SIGNATURE	DIGITAL SIGNATURE
UPENDRA JNP/ENG/0012/2017			

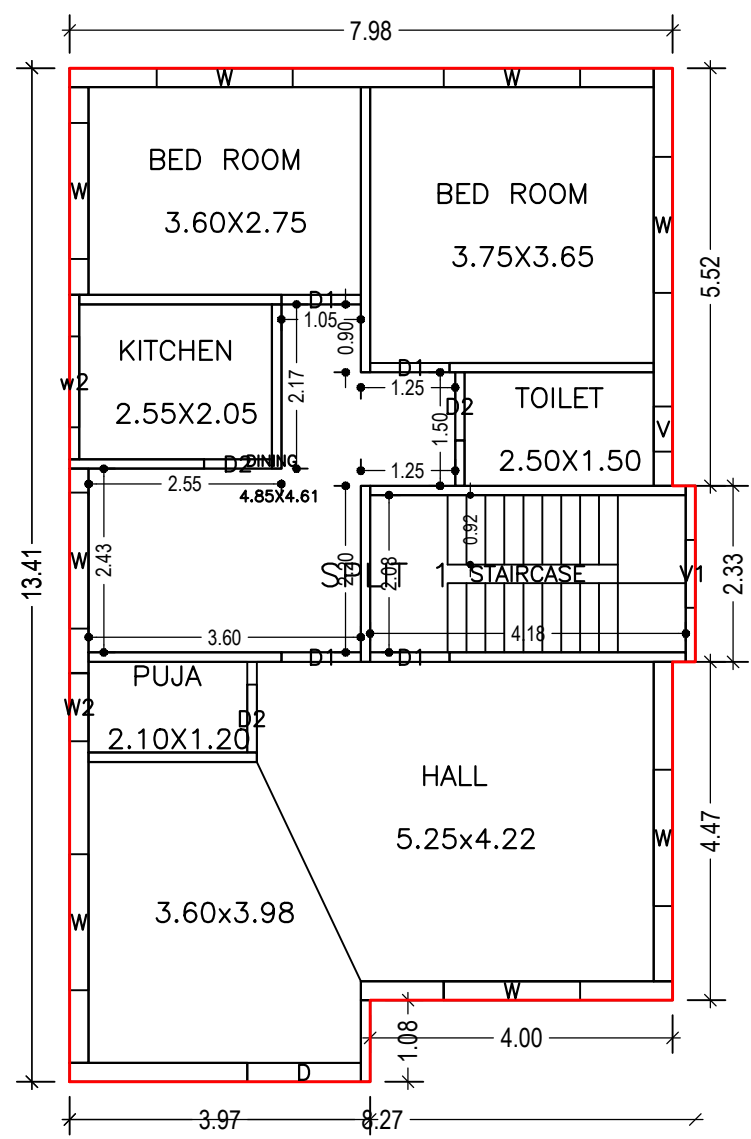

GROUND FLOOR PLAN (Proposed) (SCALE 1:100)

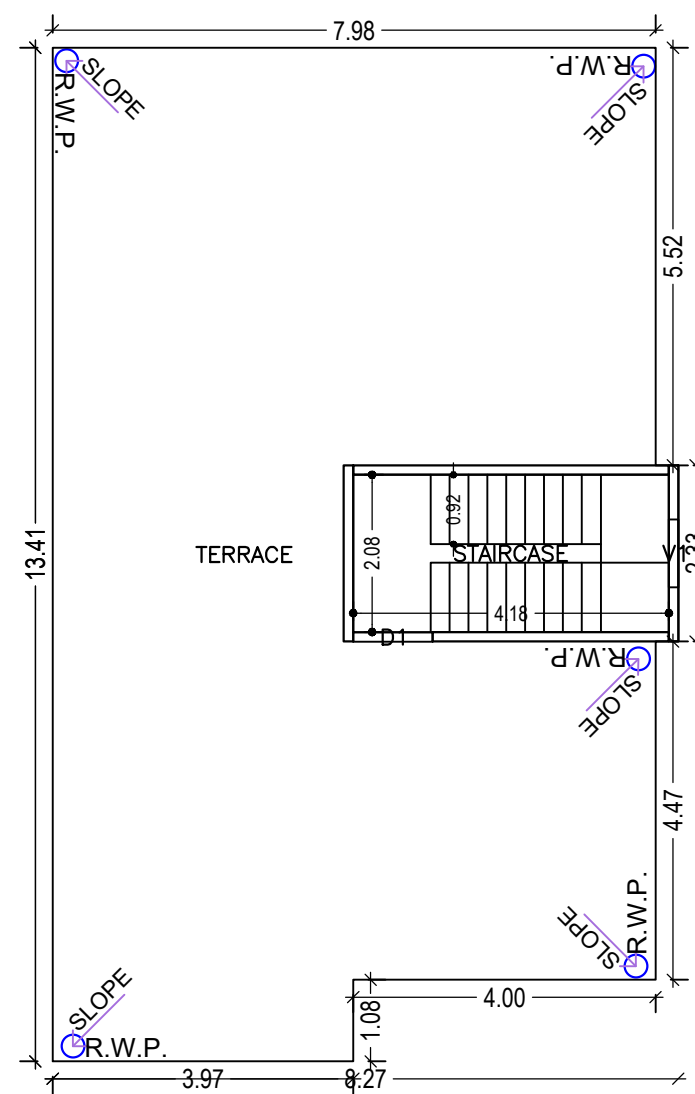

TERRACE FLOOR PLAN (SCALE 1:100)

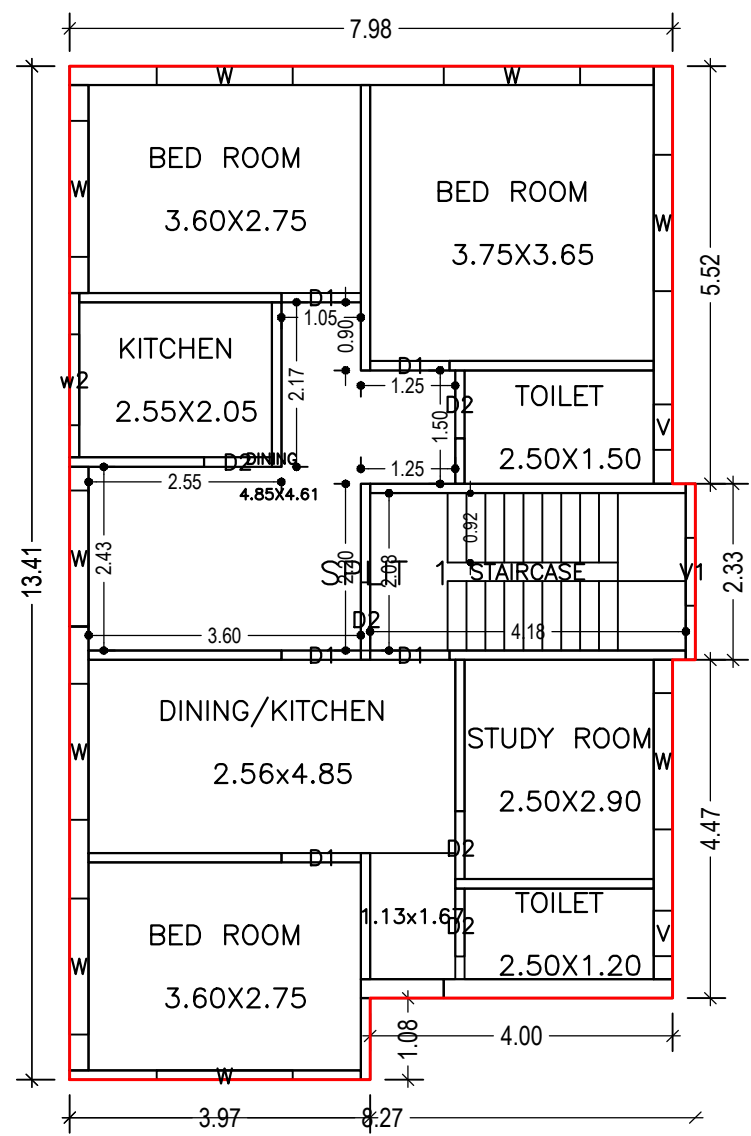

FIRST FLOOR PLAN (Proposed) (SCALE 1:100)

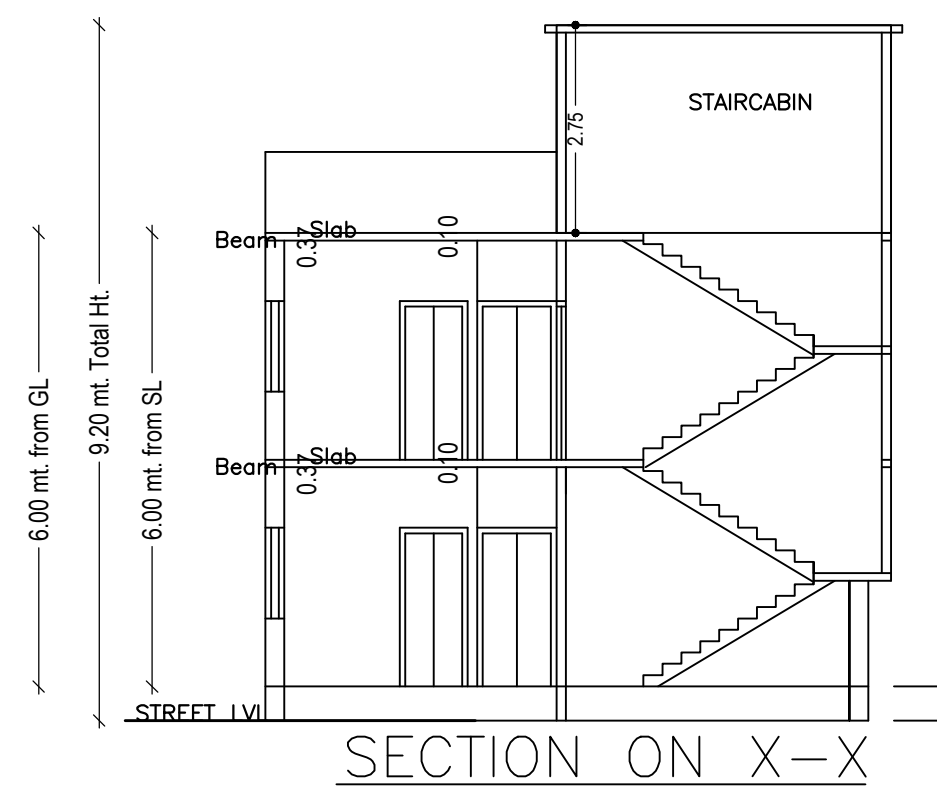

SECTION ON X-X

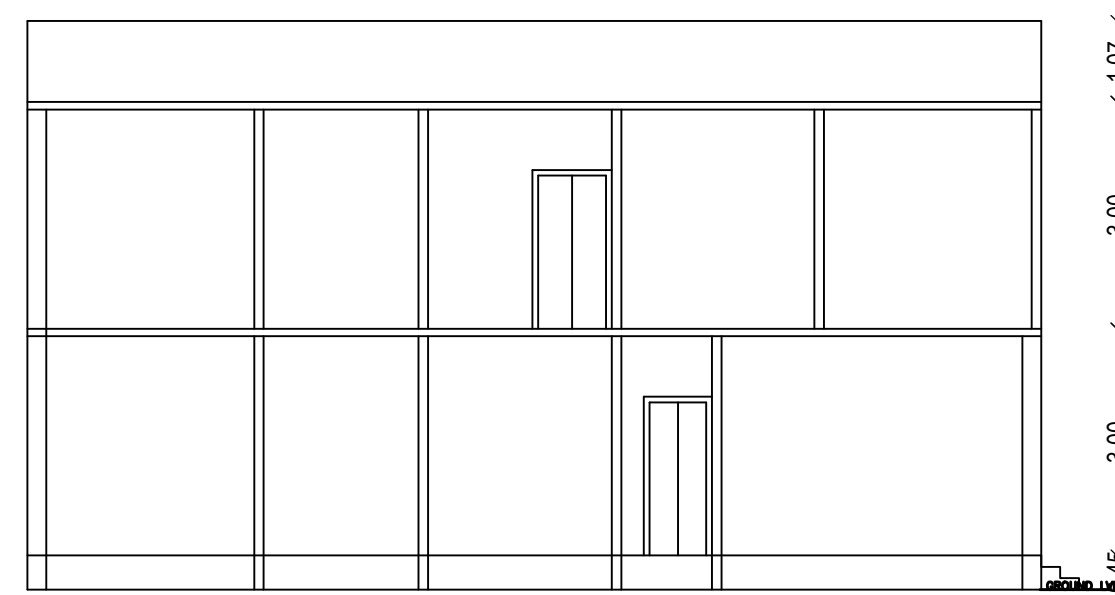

SECTION ON Y-Y

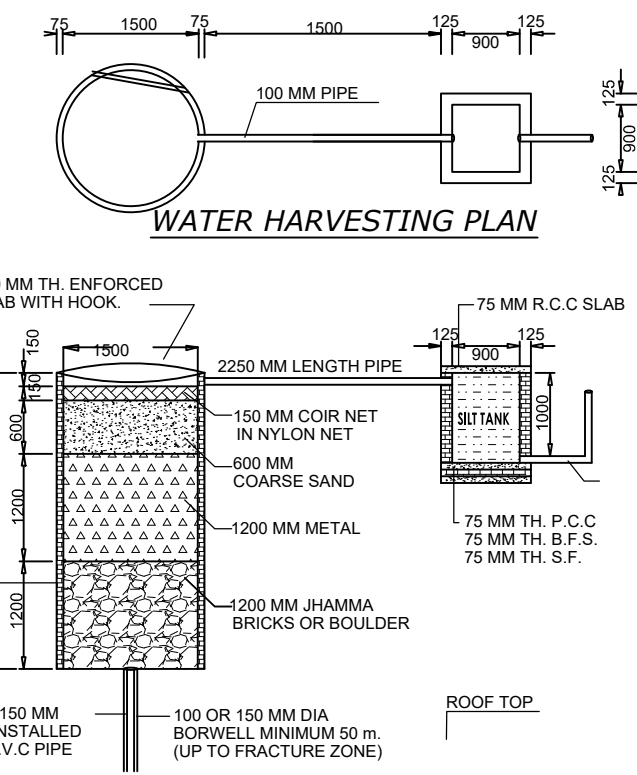

WATER HARVESTING PLAN

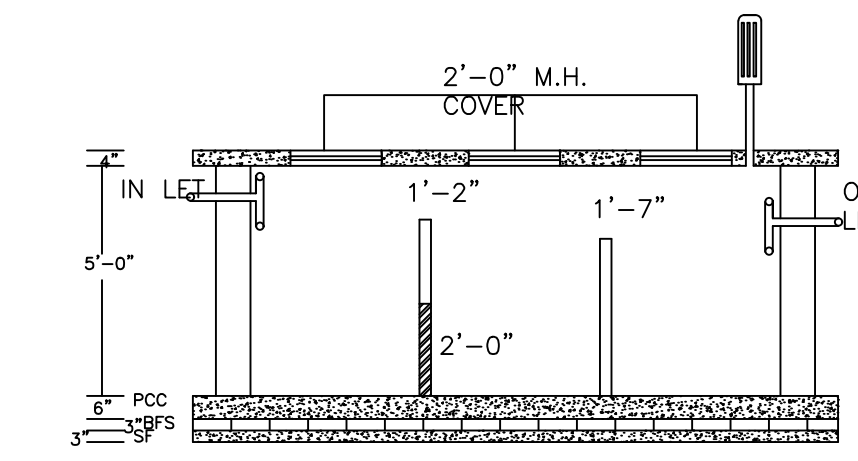

SECTION

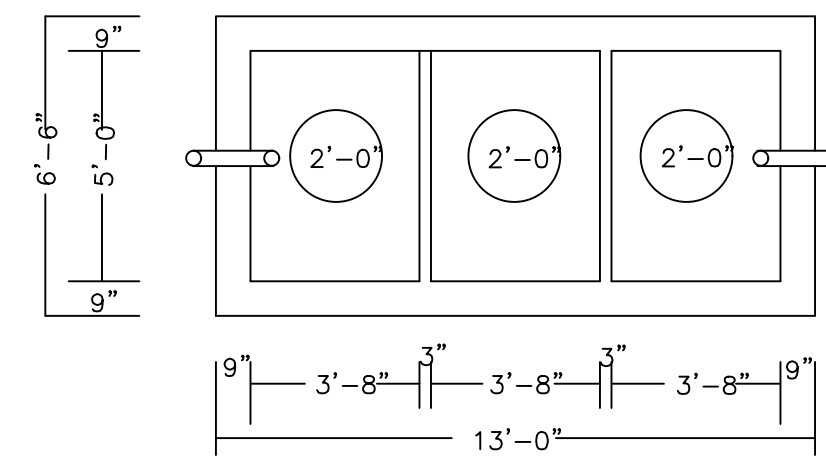

PLAN OF SEPTIC TANK (SCALE:-1IN.=4FT.)

Proposal Basic Information	
Proposal File No.	JNP/BP/0025/W01/2021
Owner Name	SMT. SUMITRA DEVI
Khata No	06
Plot No	227
Village Name	Nawada
Use	Residential
SubUse	Bungalow/ Dwelling / Non Apartment

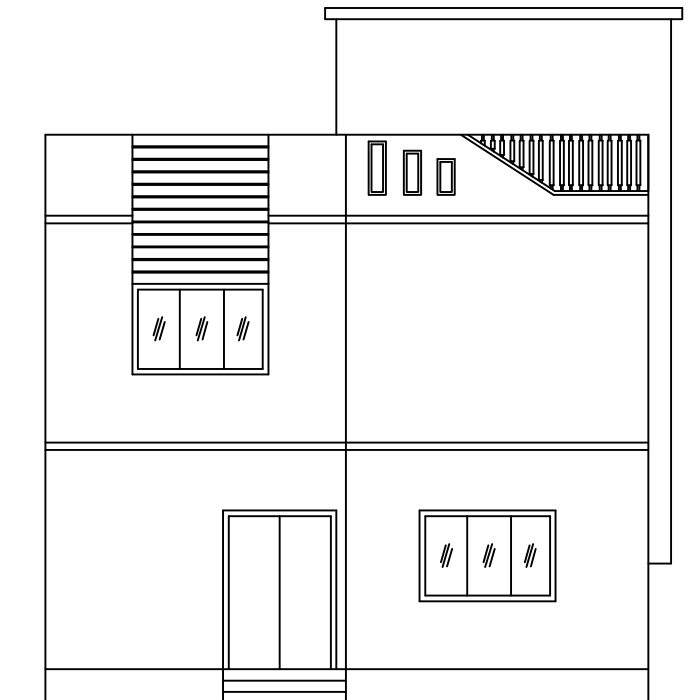

FRONT ELEVATION

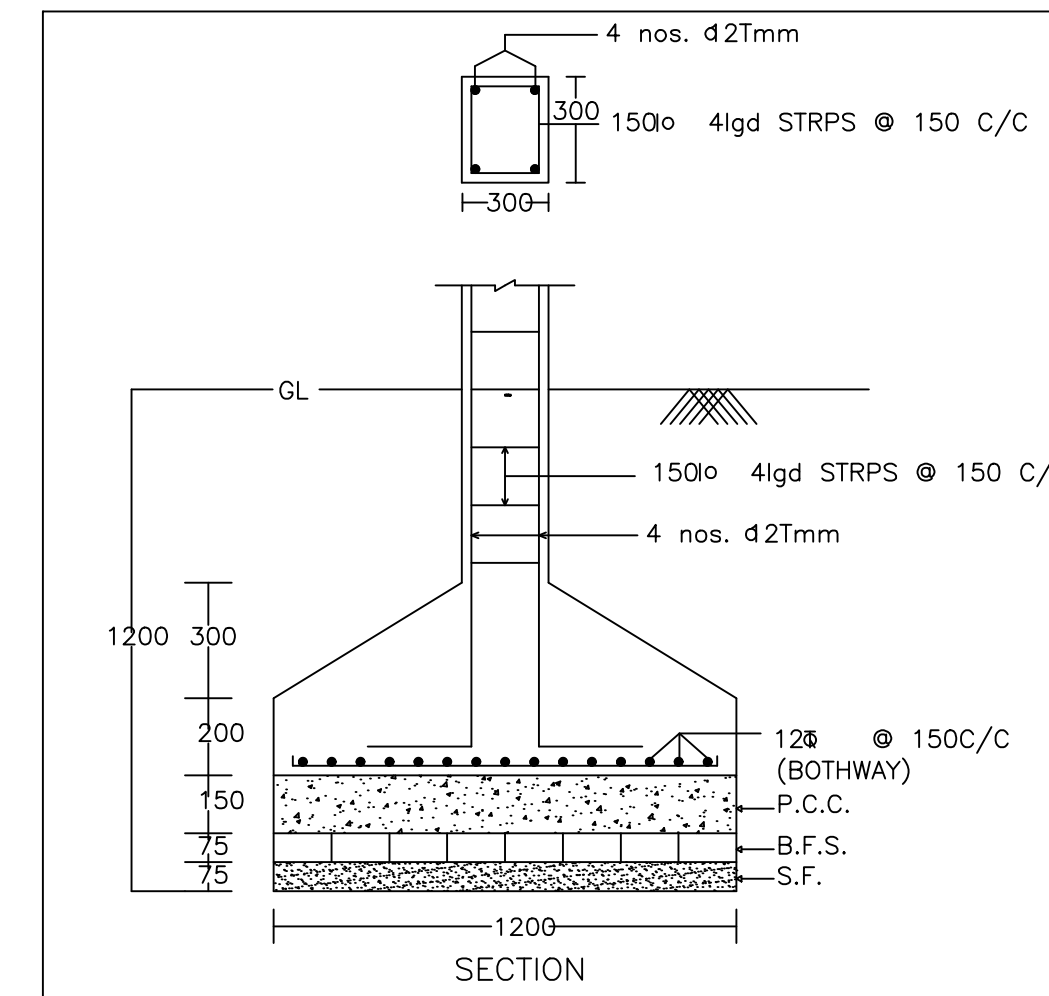

SECTION

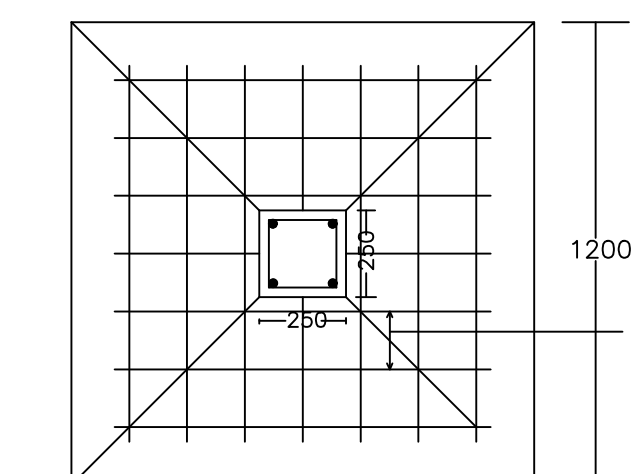

DETAIL OF COLUMNS

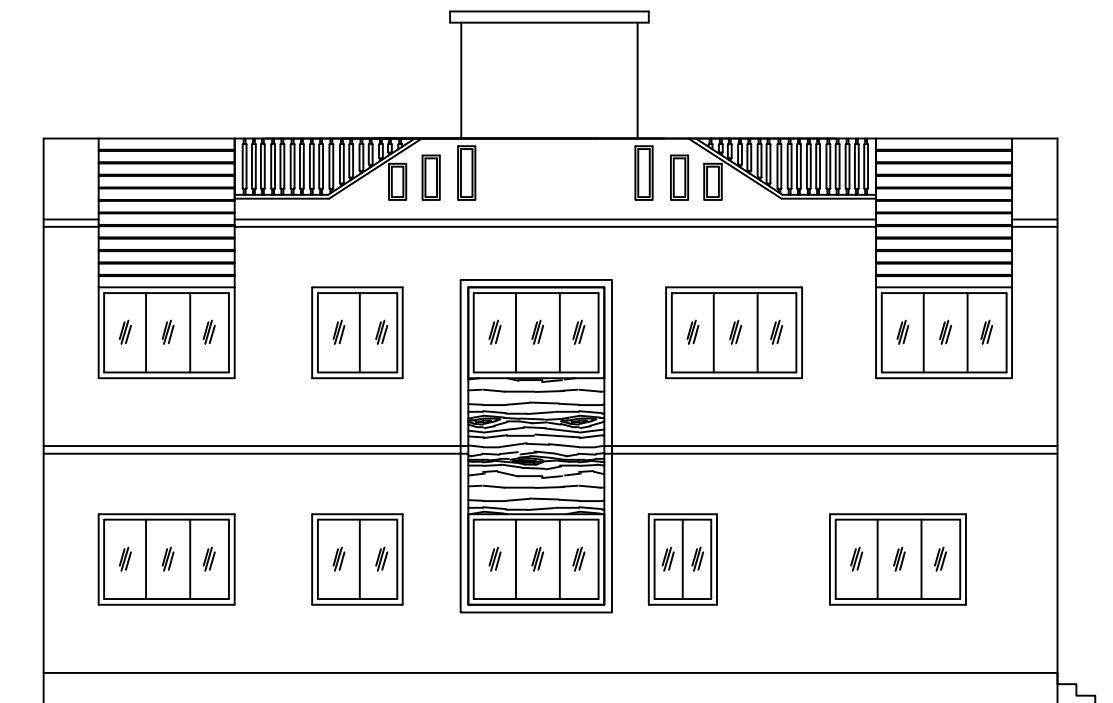

LEFT SIDE ELEVATION

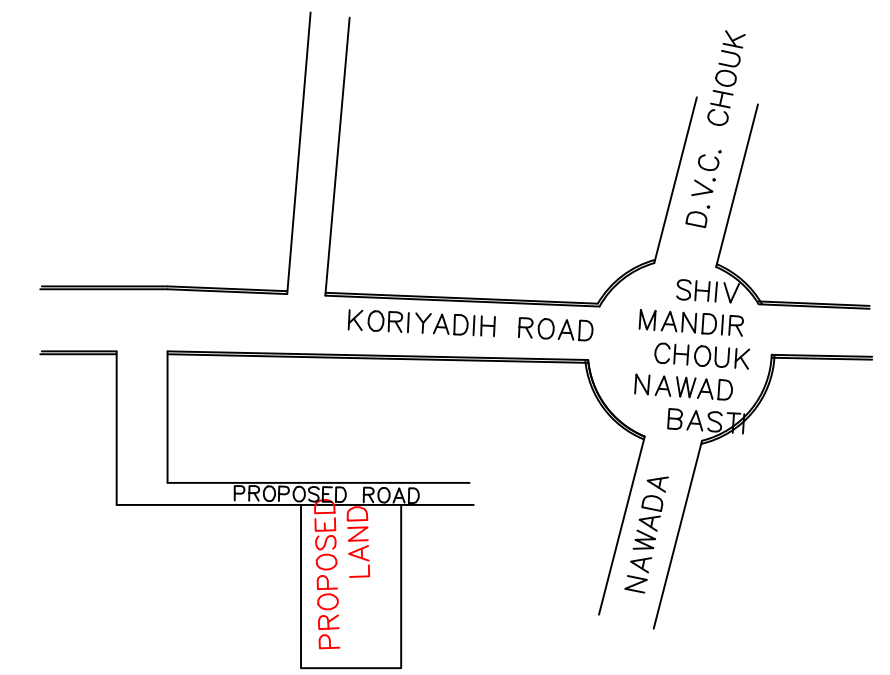

SCHEDULE OF DOOR:

BUILDING NAME	NAME	LENGTH	HEIGHT	NOS
A (SUMITRA DEVI HOUSE PLAN)	D2	0.90	2.10	08
A (SUMITRA DEVI HOUSE PLAN)	D1	1.05	2.10	09
A (SUMITRA DEVI HOUSE PLAN)	D	1.50	2.10	01

SCHEDULE OF WINDOW/VENTILATION:

BUILDING NAME	NAME	LENGTH	HEIGHT	NOS
A (SUMITRA DEVI HOUSE PLAN)	V	0.60	1.20	03
A (SUMITRA DEVI HOUSE PLAN)	V1	0.90	1.20	03
A (SUMITRA DEVI HOUSE PLAN)	W2	0.90	1.20	01
A (SUMITRA DEVI HOUSE PLAN)	w2	1.20	1.20	02
A (SUMITRA DEVI HOUSE PLAN)	W	1.80	1.20	17

UnitBUA Table for Building :A (SUMITRA DEVI HOUSE PLAN)

FLOOR	Name	UnitBUA Type	UnitBUA Area	Carpet Area	No. of Rooms	No. of Tenement
GROUND FLOOR PLAN	SPLIT 1	FLAT	206.65	180.19	7	1
FIRST FLOOR PLAN	SPLIT 1	FLAT	0.00	0.00	9	0
Total:	-	-	206.65	180.19	16	1

Building :A (SUMITRA DEVI HOUSE PLAN)

Floor Name	Total Built Up Area (Sq.mt.)	Proposed FAR Area (Sq.mt.)	Total FAR Area (Sq.mt.)	Total Consumed Additional FAR Area (Sq.mt.)	Tnmt (No.)
Ground Floor	103.32	103.32	103.32	103.32	01
First Floor	103.32	103.32	103.32	103.32	00
Terrace Floor	0.00	0.00	0.00	0.00	00
Total:	206.64	206.64	206.64	206.64	01
Total Number of Same Buildings	1				
Total:	206.64	206.64	206.64	206.64	01

LTP NAME AND SIGNATURE	STRUCTURAL ENG'S NAME AND SIGNATURE	BUILDER NAME AND SIGNATURE	DIGITAL SIGNATURE
UPENDRA JNP/ENG/0012/2017			