

SITE PLAN

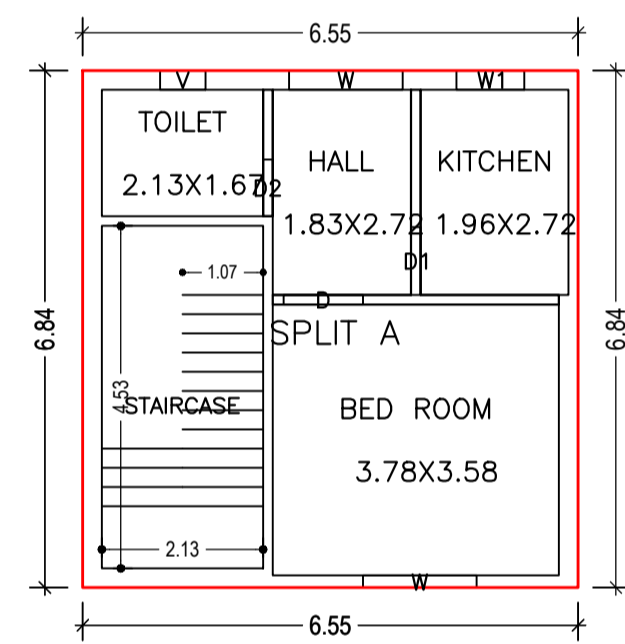

GROUND FLOOR PLAN (Proposed) (SCALE 1:100)

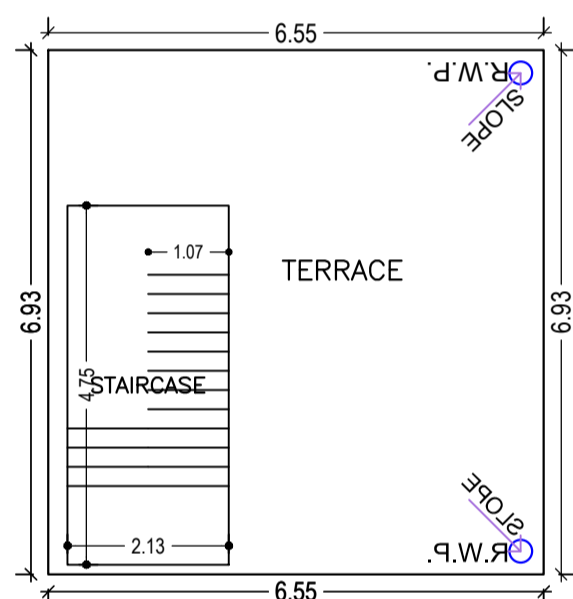

TERRACE FLOOR PLAN (SCALE 1:100)

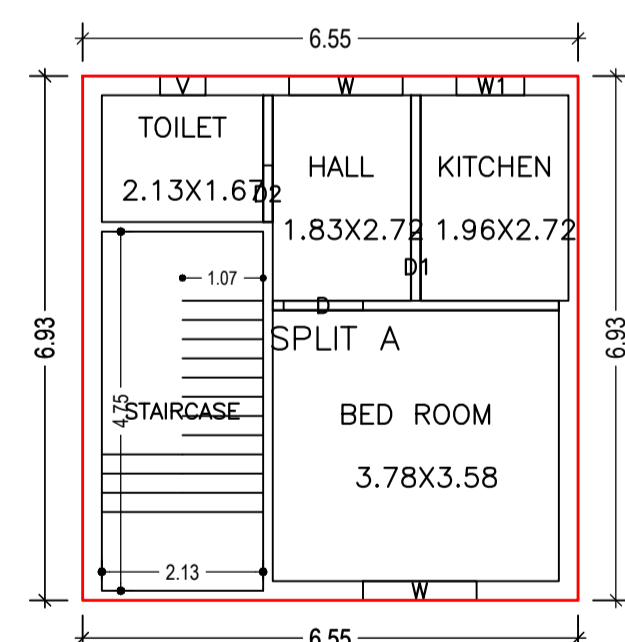

FIRST FLOOR PLAN (Proposed) (SCALE 1:100)

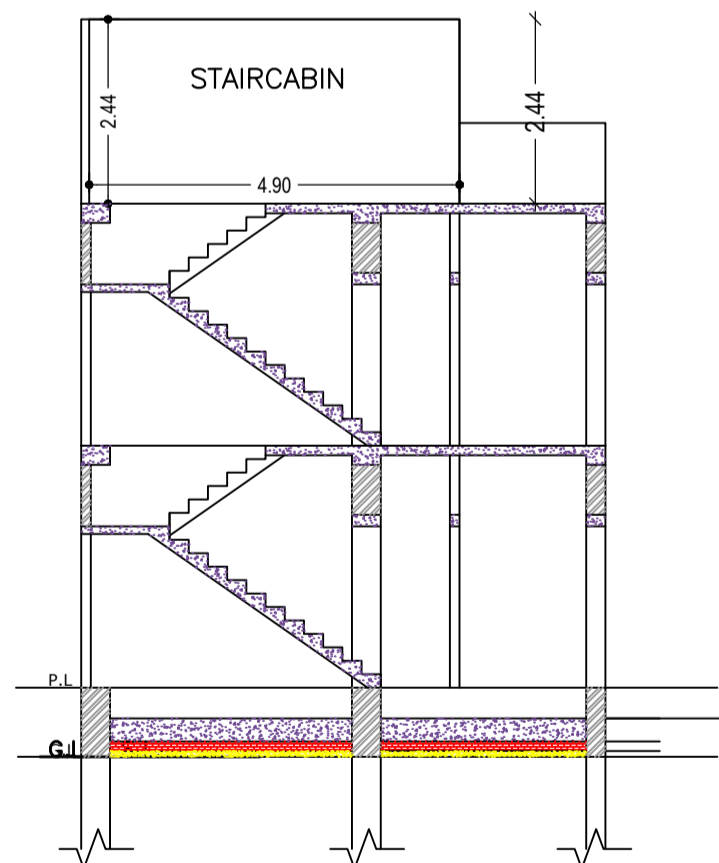

CROSS SECTION (A)

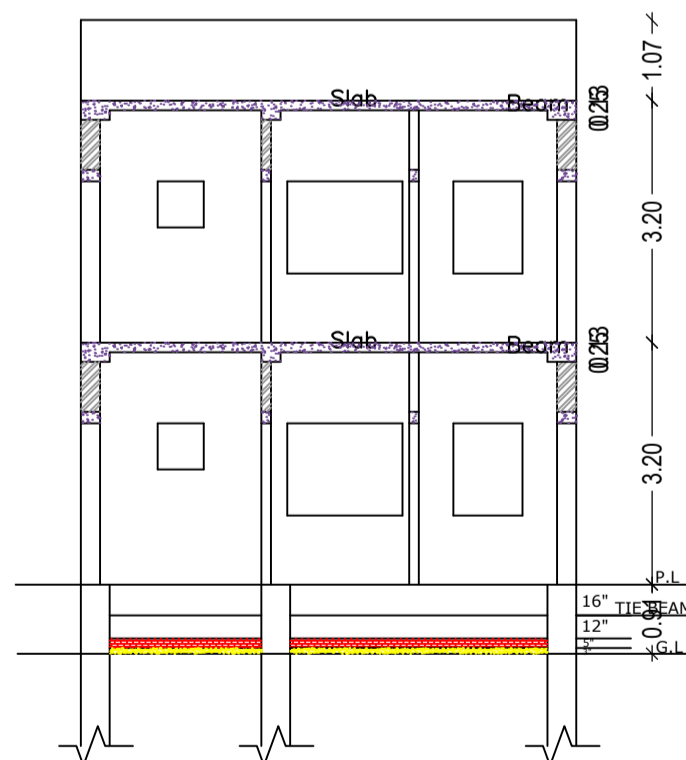

CROSS SECTION (B)

Building :A (RESIDENTIAL)

Floor Name	Total Built Up Area (Sq.mt.)	Proposed FAR Area (Sq.mt.)	Total FAR Area (Sq.mt.)	Total Consumed Additional FAR Area (Sq.mt.)	Tnmt (No.)
Ground Floor	44.80	44.80	44.80	44.80	01
First Floor	45.43	45.43	45.43	45.43	00
Terrace Floor	0.00	0.00	0.00	0.00	00
Total :	90.23	90.23	90.23	90.23	01
Total Number of Same Buildings	1				
Total :	90.23	90.23	90.23	90.23	01

SCHEDULE OF DOOR:

BUILDING NAME	NAME	LENGTH	HEIGHT	NOS
A (RESIDENTIAL)	D2	0.75	2.10	02
A (RESIDENTIAL)	D1	0.90	2.10	02
A (RESIDENTIAL)	D	1.05	2.10	02

SCHEDULE OF WINDOW/VENTILATION:

BUILDING NAME	NAME	LENGTH	HEIGHT	NOS
A (RESIDENTIAL)	V	0.60	0.75	02
A (RESIDENTIAL)	W1	0.90	1.50	02
A (RESIDENTIAL)	W	1.50	1.50	04

UnitBUA Table for Building :A (RESIDENTIAL)

FLOOR	Name	UnitBUA Type	UnitBUA Area	Carpet Area	No. of Rooms	No. of Tenement
FIRST FLOOR PLAN	SPLIT A	FLAT	0.00	0.00	4	0
GROUND FLOOR PLAN	SPLIT A	FLAT	56.88	54.81	4	1
Total:	-	-	56.88	54.81	8	1

FAR & Tenement Details (Table 4c-1)

Building	No. of Same Bldg	Total Built Up Area (Sq.mt.)	Proposed FAR Area (Sq.mt.)	Total FAR Area (Sq.mt.)	Total Consumed Additional FAR Area (Sq.mt.)	Tnmt (No.)
A (RESIDENTIAL)	1	90.23	90.23	90.23	90.23	01
Grand Total :	1	90.23	90.23	90.23	90.23	01

Proposal Basic Information

Proposal File No.	JNP/IBP/0104/W05/2021
Owner Name	(1) SRI MADAN YADAV (2) BACHCHU YADAV
Khata No	74
Plot No	1535
Village Name	Asana
Use	Residential
SubUse	Bungalow/ Dwelling / Non Apartment

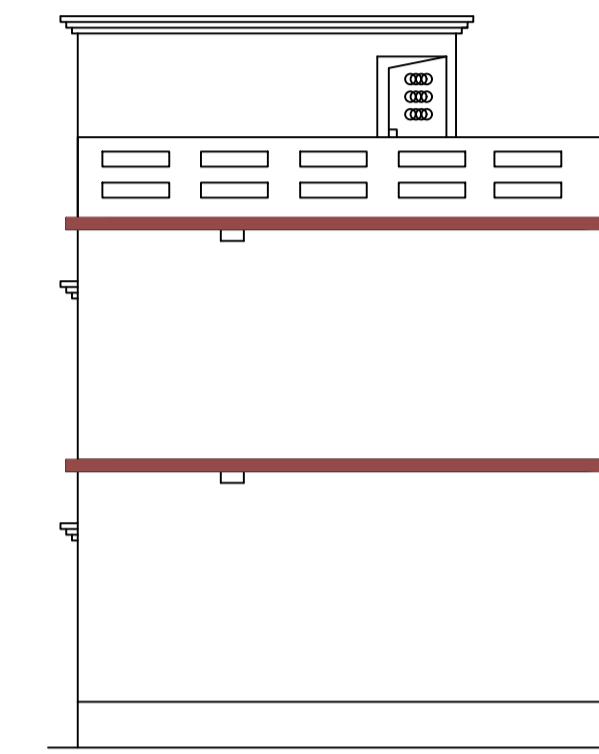
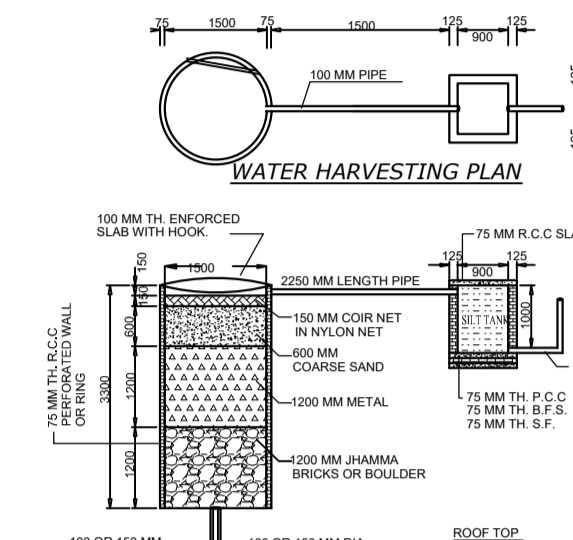

CROSS ELEVATION

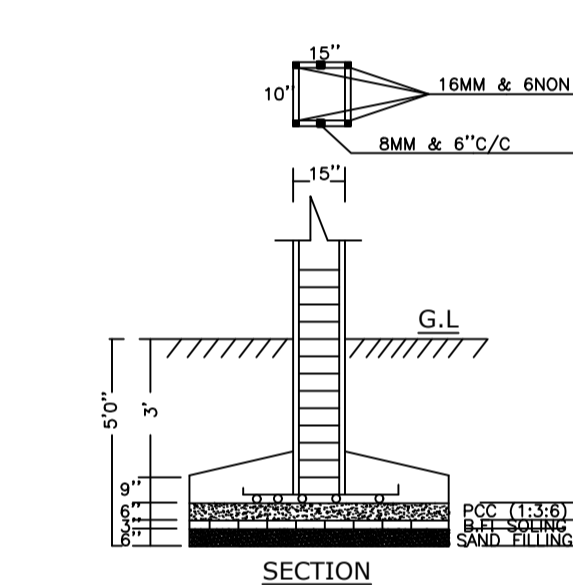

SECTION

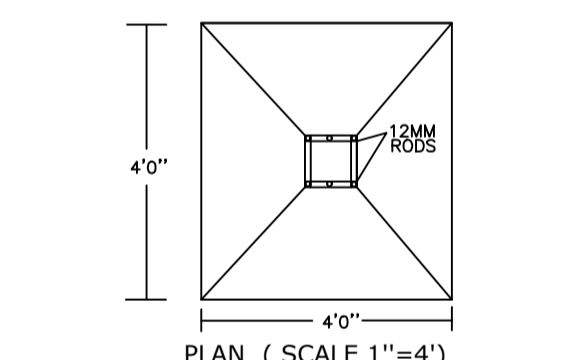

PLAN (SCALE 1''=4')

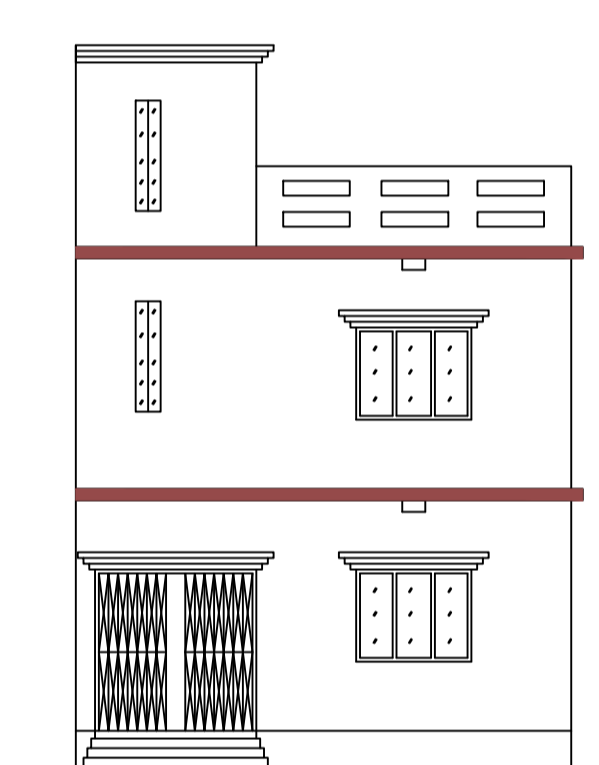

FRONT ELEVATION

AREA STATEMENT		VERSION NO. : 1.0.61	
JHUMRITILAIYA NAGAR PARISHAD		VERSION DATE: 16/10/2020	
PROJECT DETAIL:			
Region: JHARKHAND URBAN LOCAL BODIES	Plot Use: Residential		
District: KODERMA	Plot SubUse: Bungalow/ Dwelling / Non Apartment		
Authority: JHUMRITILAIYA NAGAR PARISHAD	PlotNearby/ReligiousStructure: NA		
Inward No: JNP/IBP/0104/W05/2021	PlotSubPlot No: 1535		
Application Type: General Proposal	North: Plot No. - LAND OF MALTI DEVI		
Project Type: Building Permission	South: Plot No. - LAND OF PRAYAG YADAV		
Nature of Development: New	East: Plot No. - LAND OF JAGO GOPE		
Location of Development Area: Old Area	West: Road Width - 3.4		
AREA DETAILS:			
AREA OF PLOT (Minimum)	(A)	SQ.MT.	81.34
Deduction for NetPlot Area			
Surrender Free of Cost			0.76
Total			0.76
NET AREA OF PLOT(Gross Plot Area - Deduction from Gross Plot area)	(A-Deductions)		80.58
Deduction for Balance Plot Area(from Gross Plot Area)			
Surrender Free of Cost			0.76
Common Plot			7.40
Total			8.16
BALANCE AREA OF PLOT(Net Plot Area - Recreational/Amenity space)	(A-Deductions)		73.18
PLOT AREA FOR COVERAGE(Net Plot Area)	(A-Deductions)		80.58
Plot Area for FAR (Net Plot Area + RoadWidening Area)	(A-Deductions)		81.34
COVERAGE CHECK			
Permissible Coverage area (70.00 %)			56.41
Proposed Coverage Area (55.60 %)			44.80
Total Prop. Coverage Area (55.6 %)			44.80
Balance coverage area (14.41 %)			11.61
FAR CHECK			
Perm. FAR Area (1.20)			97.61
Total Perm. FAR area			97.61
Residential FAR			90.23
Proposed FAR Area			90.23
Total Proposed FAR Area			90.23
Consumed FAR (Factor)			1.11
Balance FAR Area			7.38
BUILT UP AREA CHECK			
Total Proposed BuiltUp Area			90.23
ARCHITECT (Regd)	KIRAN KUMARI		
ENGINEER (Regd)			
SUPERVISOR (Regd)			
OWNER (Regd)	(1) SRI MADAN YADAV (2) BACHCHU YADAV		
DEVELOPMENT AUTHORITY	LOCAL BODY		

COLOR INDEX	
PLOT BOUNDARY	[Red Line]
ABUTTING ROAD	[Green Line]
PROPOSED CONSTRUCTION	[Yellow Line]
COMMON PLOT	[Blue Line]
ROAD WIDENING AREA	[Orange Line]
EXISTING (To be retained)	[Grey Line]
EXISTING (To be demolished)	[Black Line]

Buildingwise Floor FAR Details

Floor Name	Building Name A (RESIDENTIAL)		Total	
	Proposed Built Up Area (Sq.mt.)	Proposed FAR Area (Sq.mt.)	Total Proposed Built Up Area (Sq.mt.)	Total FAR Area (Sq.mt.)
Ground Floor	44.80	44.80	44.80	44.80
First Floor	45.43	45.43	45.43	45.43
Terrace Floor	0.00	0.00	0.00	0.00
Total :	90.23	90.23	90.23	90.23

Building USE/SUBUSE Details

Building Name	Building Use	Building SubUse	Building Structure
A (RESIDENTIAL)	Residential	Bungalow/ Dwelling / Non Apartment	Non-Highrise

LTP NAME AND SIGNATURE	STRUCTURAL ENG'S NAME AND SIGNATURE	BUILDER NAME AND SIGNATURE	DIGITAL SIGNATURE
KIRAN KUMARI JNP/ENG/0001/2019			