

FAR & Tenement Details (Table 4c-1)

Building	No. of Same Bldg	Total Built Up Area (Sq.mt.)	Deductions (Area in Sq.mt.) Parking	Proposed FAR Area (Sq.mt.) Resi.	Total FAR Area (Sq.mt.)	Total Consumed Additional FAR Area (Sq.mt.)	Tnmt (No.)
A (RESIDENTIAL)	1	196.26	18.38	177.88	177.88	177.88	01
Grand Total :	1	196.26	18.38	177.88	177.88	177.88	01

Proposal Basic Information

Proposal File No.	JNP/BI/0035/W01/2022
Owner Name	SRI RAJESH KUMAR RAJAK
Khata No	42
Plot No	75
Village Name	Nawada
Use	Residential
SubUse	Bungalow/ Dwelling / Non Apartment

AREA STATEMENT	VERSION NO. : 1.0.62
JHUMRITILAIYA NAGAR PARISHAD	VERSION DATE: 16/10/2020
PROJECT DETAIL:	
Region: JHARKHAND URBAN LOCAL BODIES	Plot Use: Residential
District: KODERMA	Plot SubUse: Bungalow/ Dwelling / Non Apartment
Authority: JHUMRITILAIYA NAGAR PARISHAD	PlotNearbyReligiousStructure: NA
Inward No: JNP/BI/0035/W01/2022	PlotSubPlot No: 75
Application Type: General Proposal	North: Plot No. - LAND OF SMT PREM DEVI
Project Type: Building Permission	South: Plot No. - LAND OF SMT ABHA DEVI
Nature of Development: New	East: Plot No. - LAND OF SRI PANKAJ SAHAJ
Location of Development Area: Old Area	West: Road Width - 3.96
AREA DETAILS:	
AREA OF PLOT (Minimum)	(A) 161.47
NET AREA OF PLOT(Gross Plot Area - Deduction from Gross Plot area)	(A-Deductions) 161.47
Deduction for Balance Plot Area(from Gross Plot Area)	
Common Plot	21.14
BALANCE AREA OF PLOT(Net Plot Area - Recreational/Amenity space)	(A-Deductions) 140.33
PLOT AREA FOR COVERAGE(Net Plot Area)	(A-Deductions) 161.47
Plot Area for FAR (Net Plot Area + RoadWidening Area)	(A-Deductions) 161.47
COVERAGE CHECK	
Permissible Coverage area (70.00 %)	113.03
Proposed Coverage Area (60.77 %)	98.13
Total Prop. Coverage Area (60.77 %)	98.13
Balance coverage area (9.23 %)	14.90
FAR CHECK	
Perm. FAR Area (1.50)	242.21
Total Perm. FAR area	242.21
Residential FAR	177.88
Proposed FAR Area	177.88
Total Proposed FAR Area	177.88
Consumed FAR (Factor)	1.10
Balance FAR Area	64.33
BUILT UP AREA CHECK	
Total Proposed BuiltUp Area	196.26
ARCHITECT (Regd)	KIRAN KUMARI
ENGINEER (Regd)	
SUPERVISOR (Regd)	
OWNER (Regd)	SRI RAJESH KUMAR RAJAK
DEVELOPMENT AUTHORITY	LOCAL BODY

COLOR INDEX	
PLOT BOUNDARY	Black
ABUTTING ROAD	Green
PROPOSED CONSTRUCTION	Red
COMMON PLOT	White
ROAD WIDENING AREA	Yellow
EXISTING (To be retained)	Blue
EXISTING (To be demolished)	Orange

Buildingwise Floor FAR Details

Floor Name	Building Name A (RESIDENTIAL)		Total	
	Proposed Built Up Area (Sq.mt.)	Proposed FAR Area (Sq.mt.)	Total Proposed Built Up Area (Sq.mt.)	Total FAR Area (Sq.mt.)
Ground Floor	98.13	79.75	98.13	79.75
First Floor	98.13	98.13	98.13	98.13
Terrace Floor	0.00	0.00	0.00	0.00
Total :	196.26	177.88	196.26	177.88

Building USE/SUBUSE Details

Building Name	Building Use	Building SubUse	Building Structure
A (RESIDENTIAL)	Residential	Bungalow/ Dwelling / Non Apartment	Non-Highrise

LTP NAME AND SIGNATURE	STRUCTURAL ENG'S NAME AND SIGNATURE	BUILDER NAME AND SIGNATURE	DIGITAL SIGNATURE
KIRAN KUMARI JNP/ENG/001/2019			

Proposal Basic Information	
Proposal File No.	JNP/BP/0035/W01/2022
Owner Name	SRI RAJESH KUMAR RAJAK
Khata No	42
Plot No	75
Village Name	Nawada
Use	Residential
SubUse	Bungalow/ Dwelling / Non Apartment

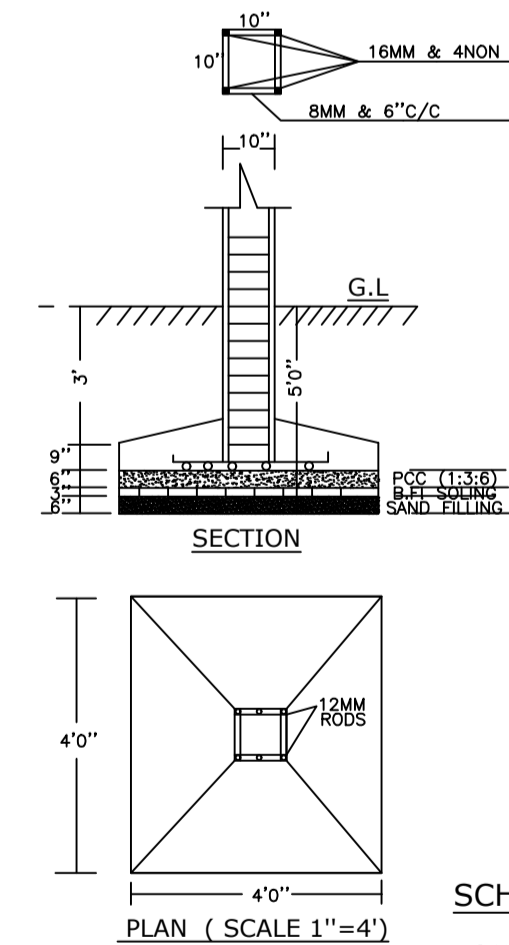
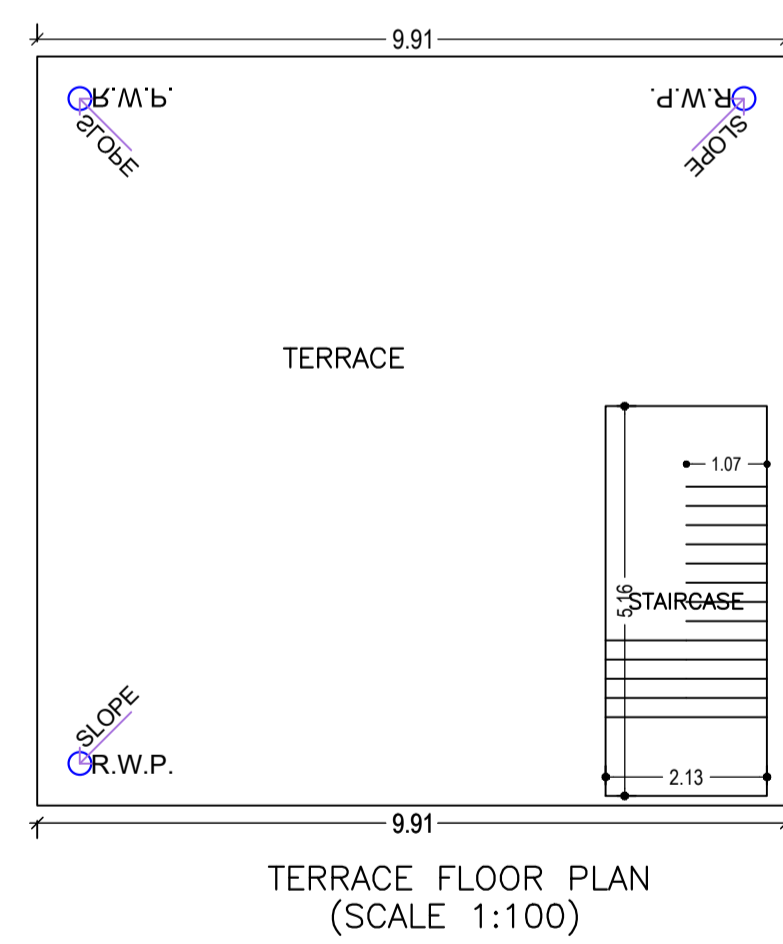
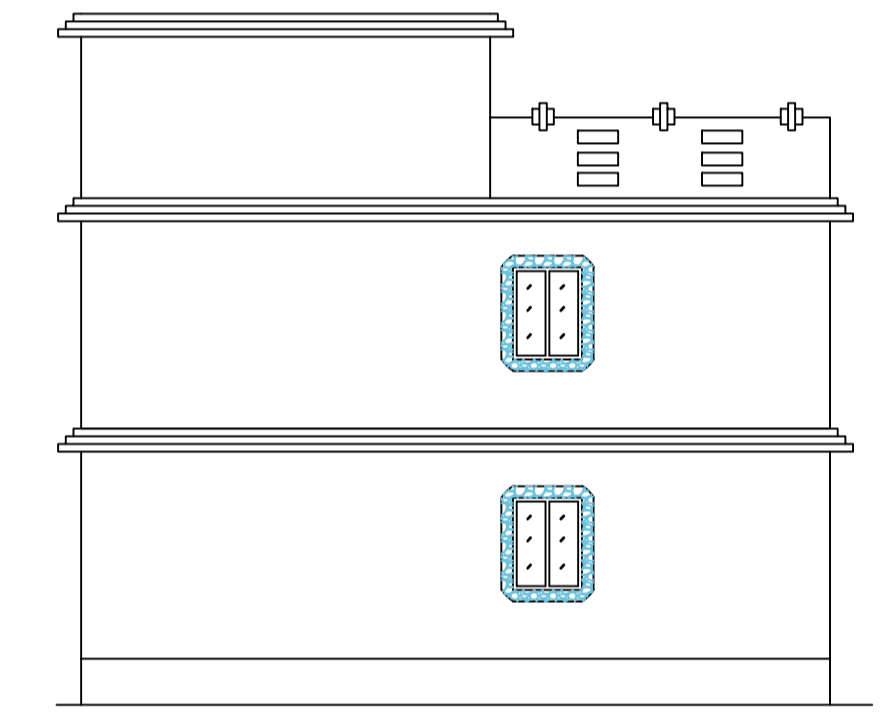
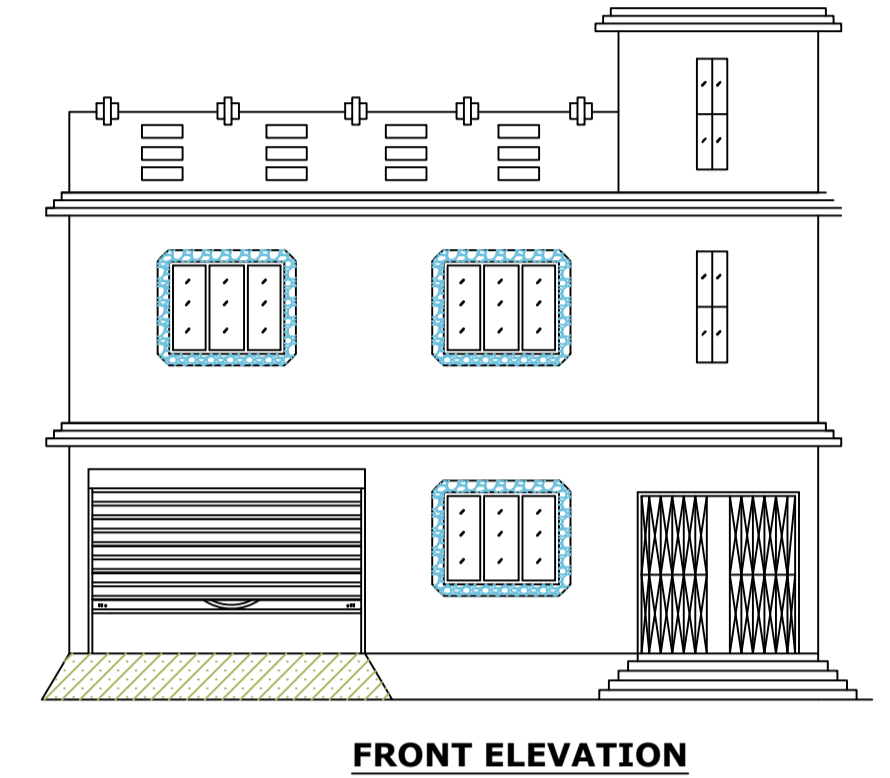
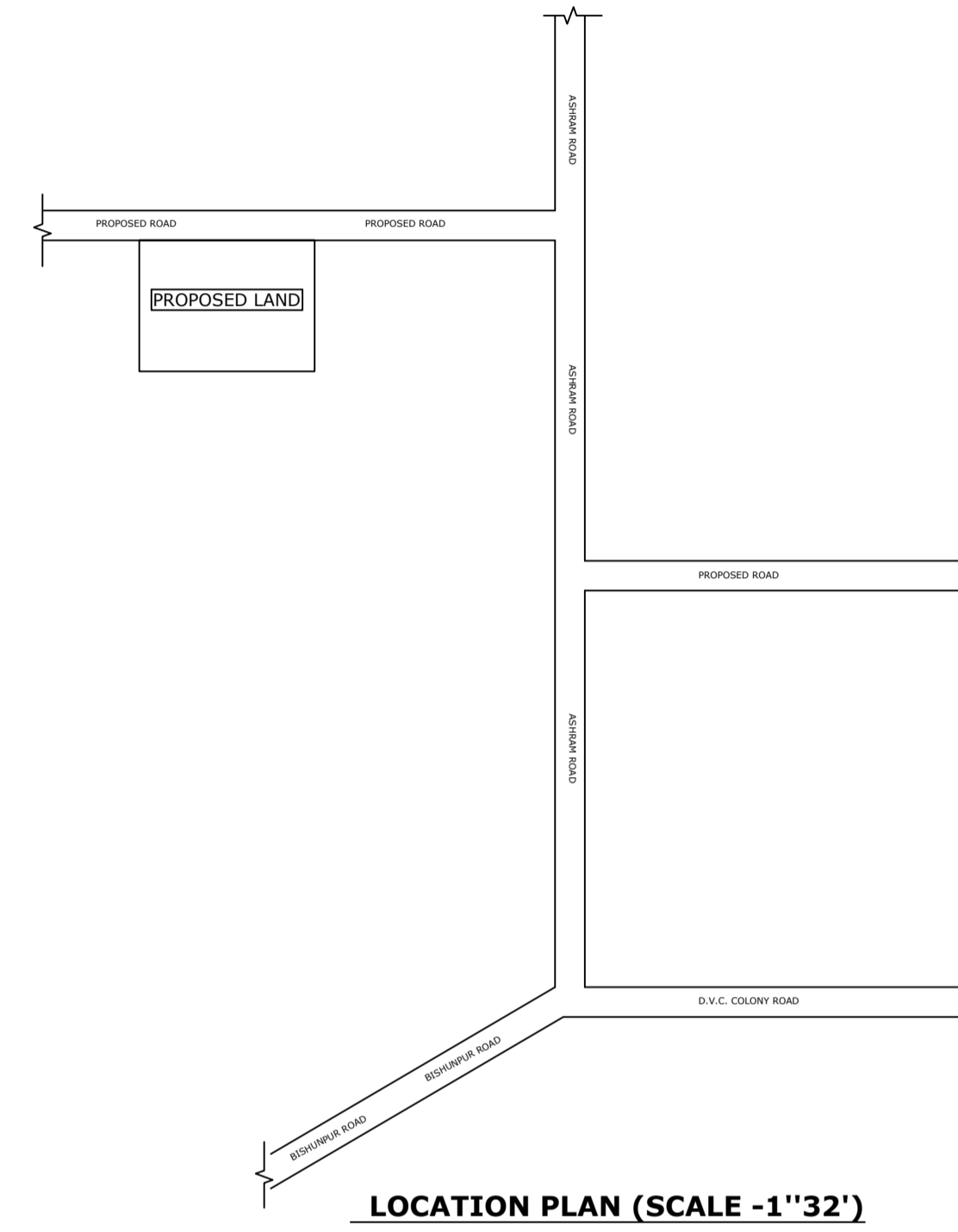
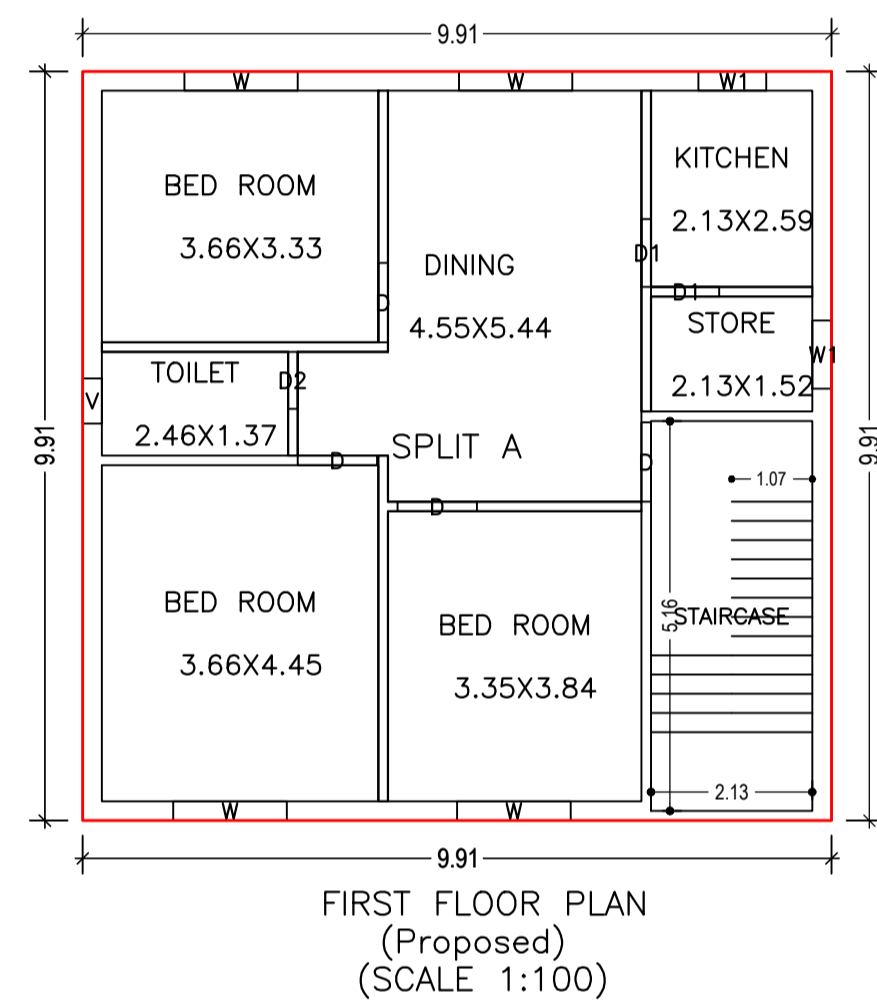
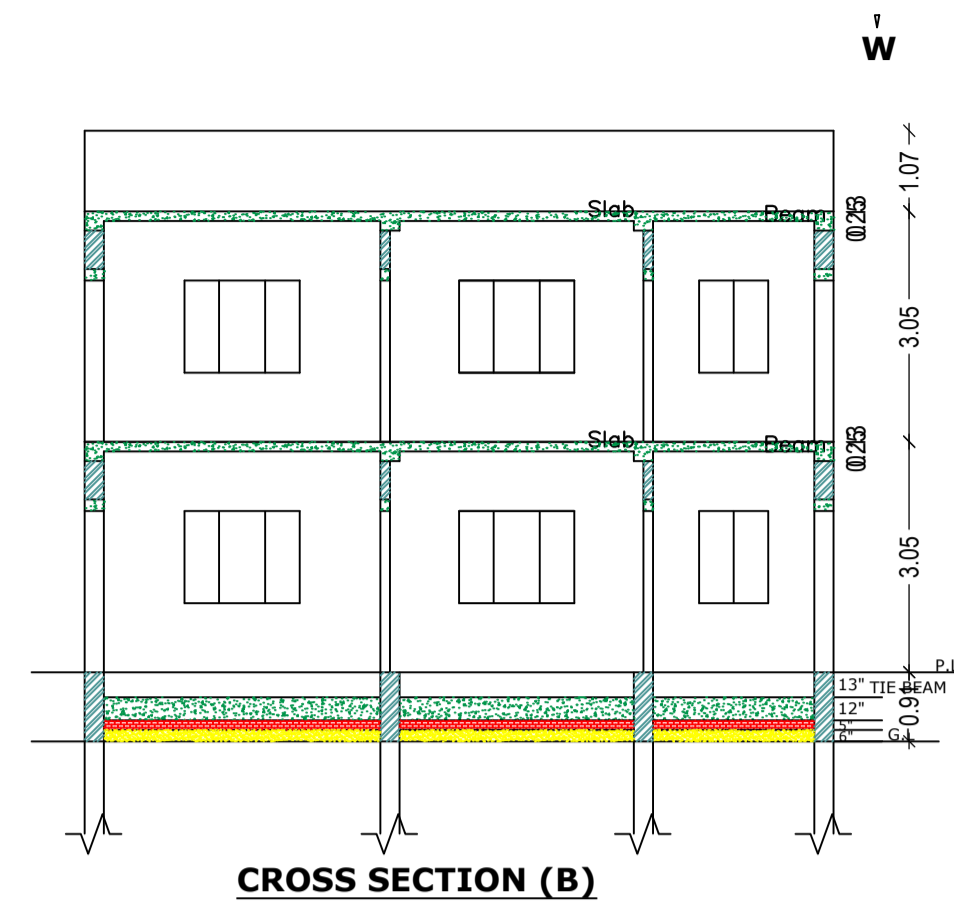
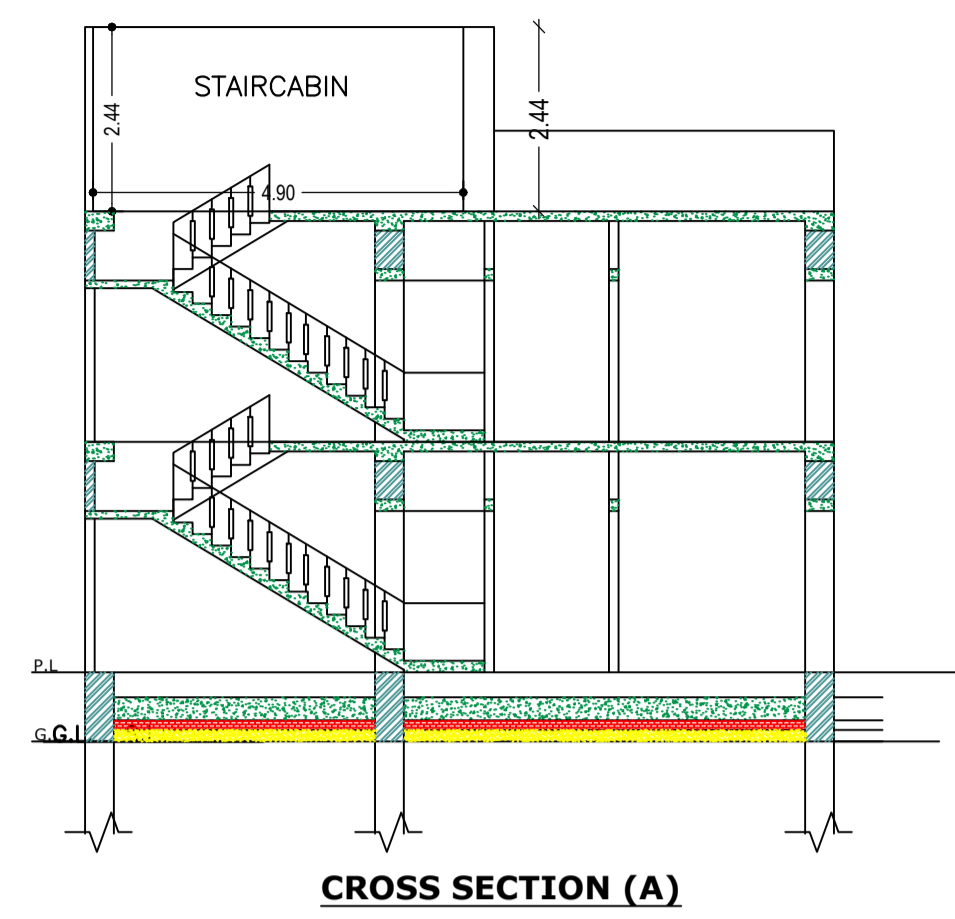
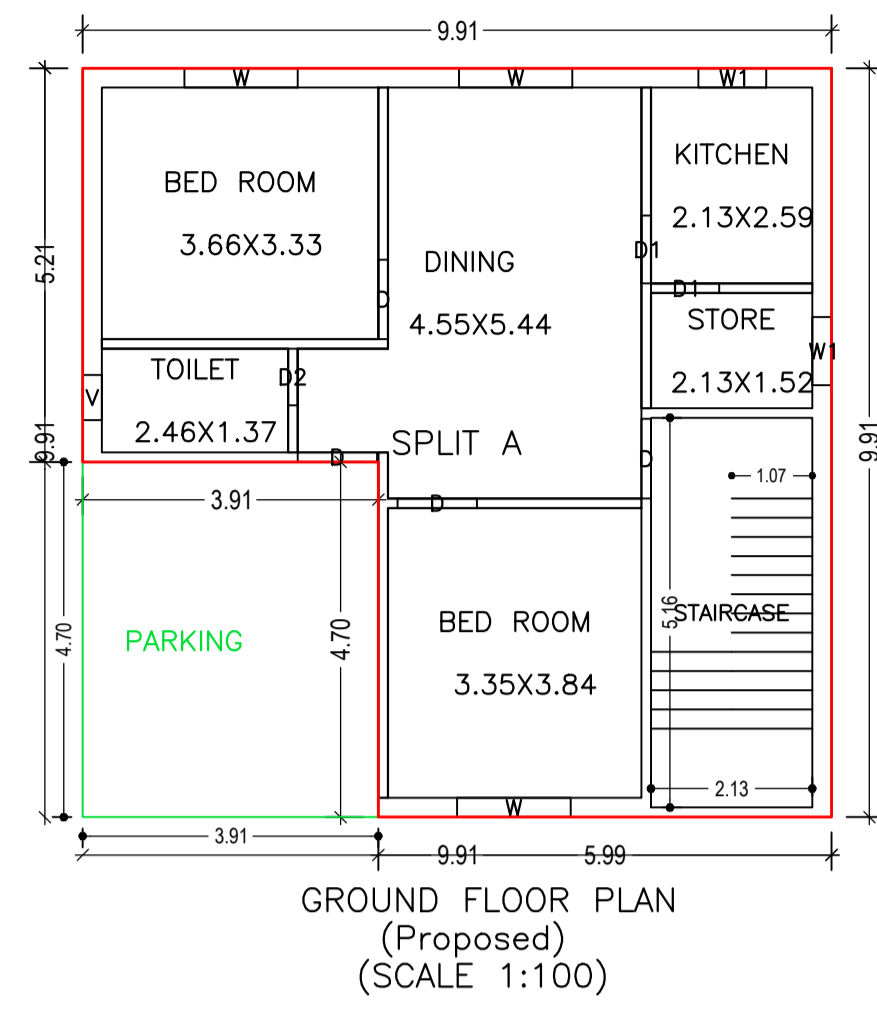

SCHEDULE OF DOORS/WINDOWS

S.NO.	TYPE
1	D2
2	D1
3	D
4	V
5	W1
6	W

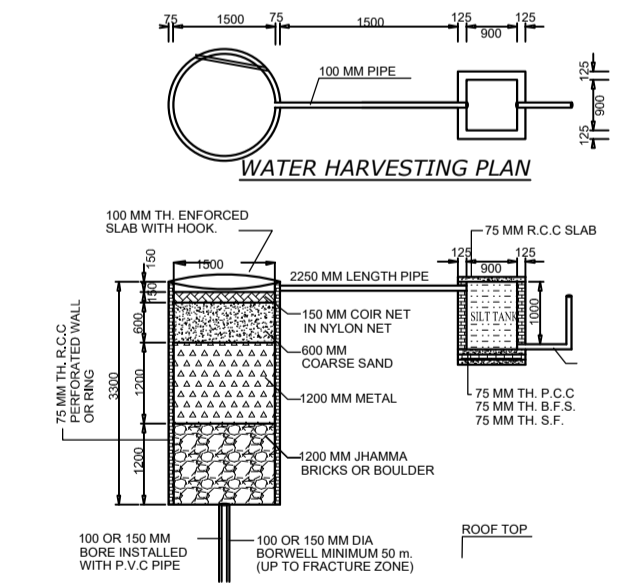
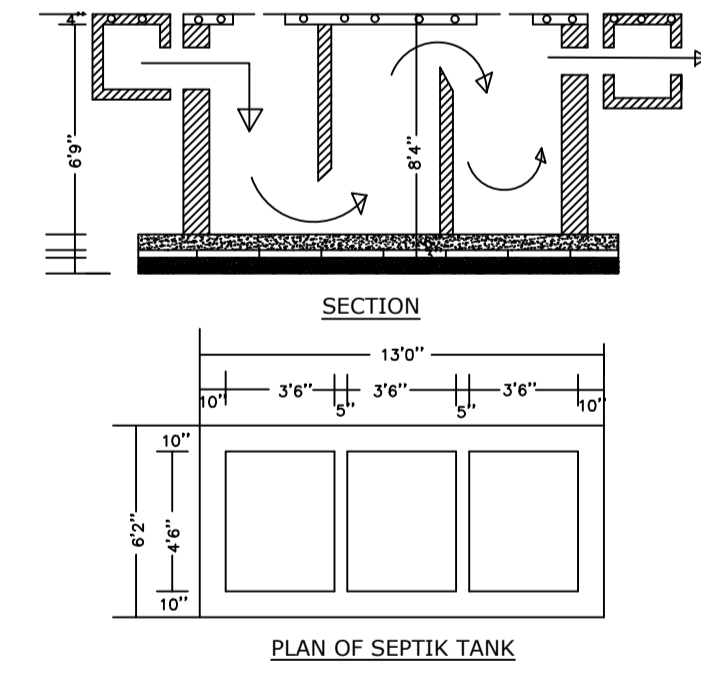

Building :A (RESIDENTIAL)

Floor Name	Total Built Up Area (Sq.mt.)	Deductions (Area in Sq.mt.)	Proposed FAR Area (Sq.mt.)	Total FAR Area (Sq.mt.)	Total Consumed Additional FAR Area (Sq.mt.)	Trmt (No.)
Ground Floor	98.13	18.38	79.75	79.75	79.75	01
First Floor	98.13	0.00	98.13	98.13	98.13	00
Terrace Floor	0.00	0.00	0.00	0.00	0.00	00
Total :	196.26	18.38	177.88	177.88	177.88	01
Total Number of Same Buildings	1					
Total :	196.26	18.38	177.88	177.88	177.88	01

SCHEDULE OF DOOR:

BUILDING NAME	NAME	LENGTH	HEIGHT	NOS
A (RESIDENTIAL)	D2	0.75	2.10	02
A (RESIDENTIAL)	D1	0.90	2.10	04
A (RESIDENTIAL)	D	1.05	2.10	08

SCHEDULE OF WINDOW/VENTILATION:

BUILDING NAME	NAME	LENGTH	HEIGHT	NOS
A (RESIDENTIAL)	V	0.60	0.75	02
A (RESIDENTIAL)	W1	0.90	1.50	04
A (RESIDENTIAL)	W	1.50	1.50	07

UnitBUA Table for Building :A (RESIDENTIAL)

FLOOR	Name	UnitBUA Type	UnitBUA Area	Carpet Area	No. of Rooms	No. of Tenement
GROUND FLOOR PLAN	SPLIT A	FLAT	136.61	130.82	6	1
FIRST FLOOR PLAN	SPLIT A	FLAT	0.00	0.00	7	0
Total:	-	-	136.61	130.82	13	1

LTP NAME AND SIGNATURE	STRUCTURAL ENG'S NAME AND SIGNATURE	BUILDER NAME AND SIGNATURE	DIGITAL SIGNATURE
KIRAN KUMARI JNP/ENG/0001/2019			