

Project Title :SRI RAJESH KUMAR

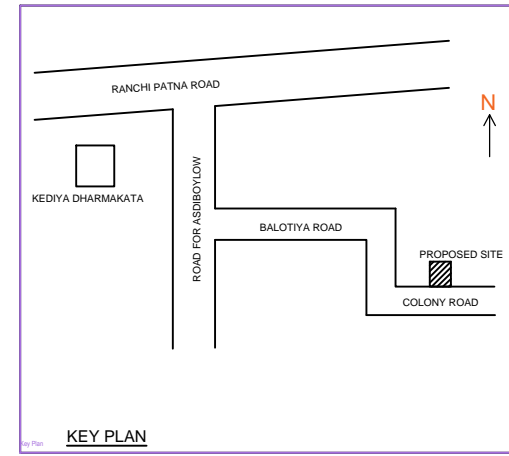
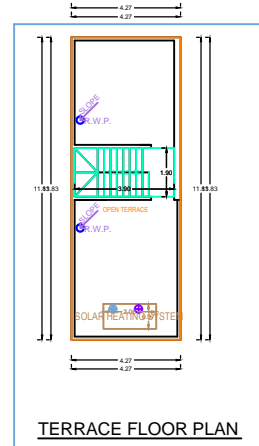
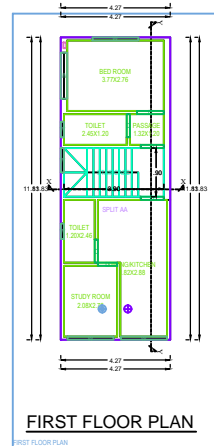
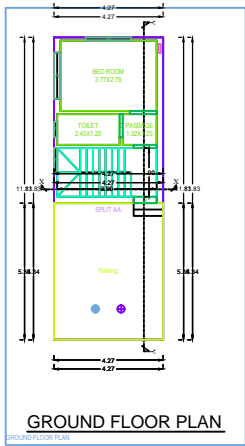
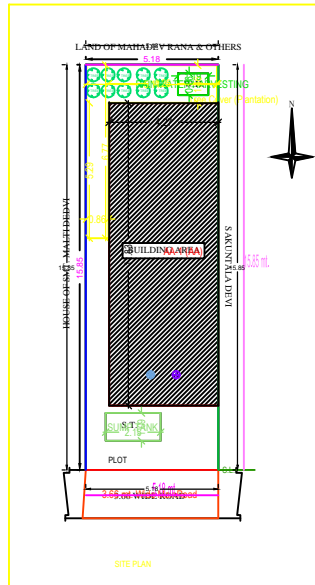
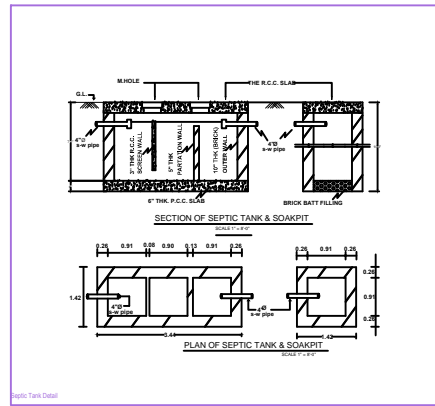
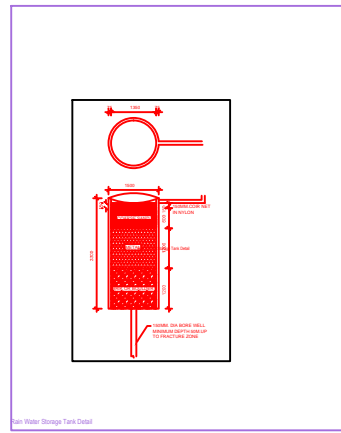
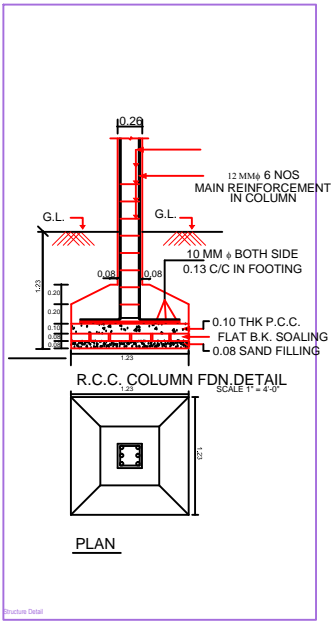
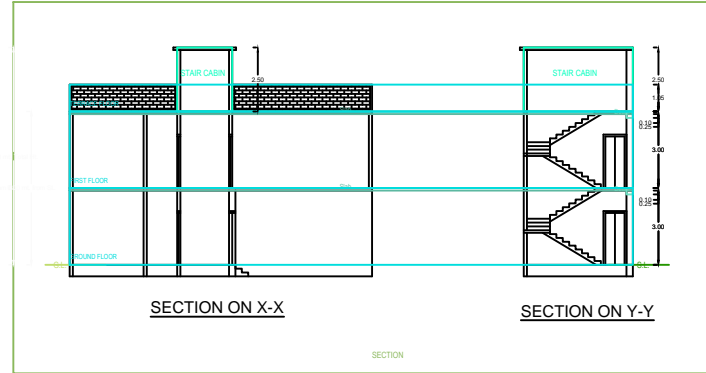
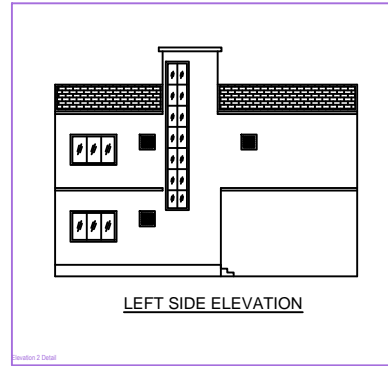
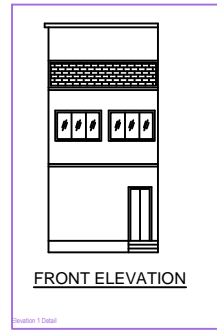

PROJECT DETAIL	
Project No.:	123.80
Client:	SHRI RAJESH KUMAR
Location:	RAJESH KUMAR
Area:	123.80 Sq. Mtr.
Scale:	1:20
Author:	RAJESH KUMAR
Check:	RAJESH KUMAR
Date:	12/12/2023

COLOR INDEX	
Plot Boundary	Red
Building Area	Green
Proposed Work (Coverage Area)	Blue
Existing (To be retained)	Yellow
Existing (To be demolished)	Black

PARKING CALCULATION		
Parking Type	Prop. No.	Prop. Area
Other Parking	1	22.83
Total Area	1	22.83

MARGIN DETAIL					
Building / Wing	Front Margin	Rear Margin	Side Margin	Setback	Setback
AA (AA)	2.01	0.91	0.91	0.91	0.91

FAR & Tenement Details (Table 4c-1)						
Building	No. of Same Bldg.	Total Built Up Area (Sq.mt.)	Deductions (Area in Sq.mt.)	Proposed FAR Area (Sq.mt.)	Total FAR Area (Sq.mt.)	Tenement (No.)
AA (AA)	1	123.80	22.83	101.06	101.06	01
<b>Grand Total</b>	<b>1</b>	<b>123.80</b>	<b>22.83</b>	<b>101.06</b>	<b>101.06</b>	<b>01</b>

Floor Name	Total Built Up Area (Sq.mt.)	Deductions (Area in Sq.mt.)	Proposed FAR Area (Sq.mt.)	Total FAR Area (Sq.mt.)	Tenement (No.)
Ground Floor	123.80	22.83	101.06	101.06	01
First Floor	0.00	0.00	0.00	0.00	00
Terrace Floor	0.00	0.00	0.00	0.00	00
<b>Total</b>	<b>123.80</b>	<b>22.83</b>	<b>101.06</b>	<b>101.06</b>	<b>01</b>

SCHEDULE OF JOINERY:				
BUILDING NAME	NAME	LENGTH	HEIGHT	NO.
AA (AA)	D	6.75	2.10	01
AA (AA)	D	6.90	1.20	02
AA (AA)	D	1.05	2.10	02
<b>Total</b>	-	-	-	<b>05</b>

SCHEDULE OF JOINERY:				
BUILDING NAME	NAME	LENGTH	HEIGHT	NO.
AA (AA)	W	0.60	1.20	03
AA (AA)	W	0.90	1.20	02
AA (AA)	W	1.80	1.20	01
<b>Total</b>	-	-	-	<b>06</b>

UNBIA Table for Building AA (AA)						
FLOOR	Name	UNBIA Type	Usable Area	Carpet Area	No. of Rooms	No. of Tenement
GROUND FLOOR	SPLIT AA	FLAT	101.06	101.01	3	1
<b>Total</b>	-	-	<b>101.06</b>	<b>101.01</b>	<b>3</b>	<b>1</b>