

Project Title :PROPOSED BUILDING PLAN FOR:- SMT SONI DEVI
W/O - SRI PRADEEP KUMAR SINGH . MAUZA-NAWADA .WARD NO-01. P.S-TELAIYA. P.S NO- 249. KHATA NO- 36.
PLOT NO- 64. DISTT-KODERMA (JHARAKHAND)

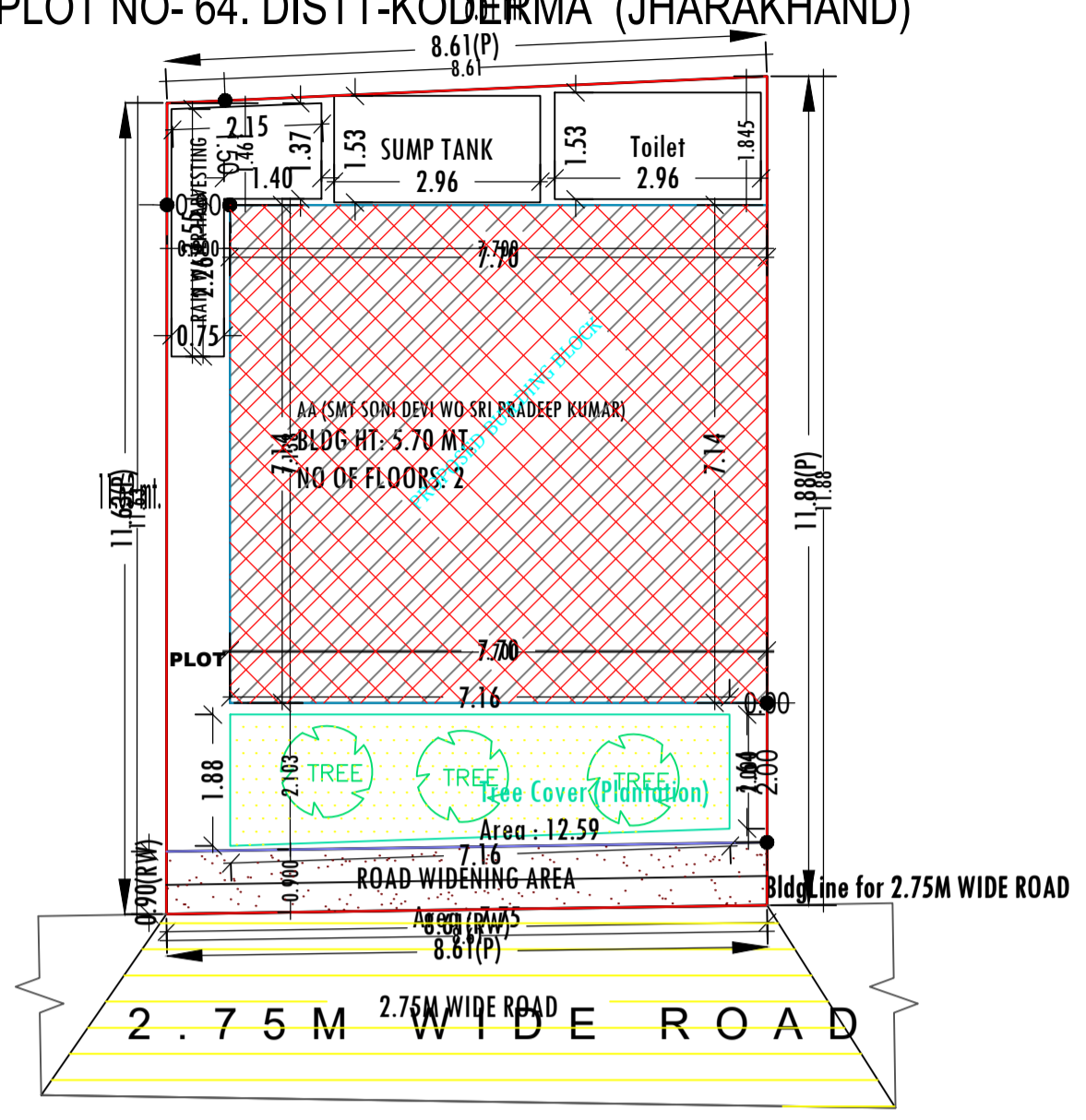

SITE PLAN
SCALE :- 1=200

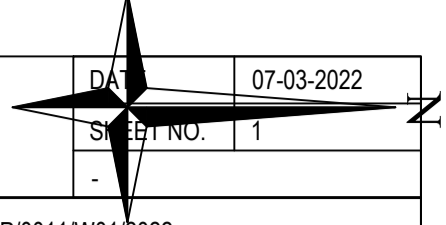
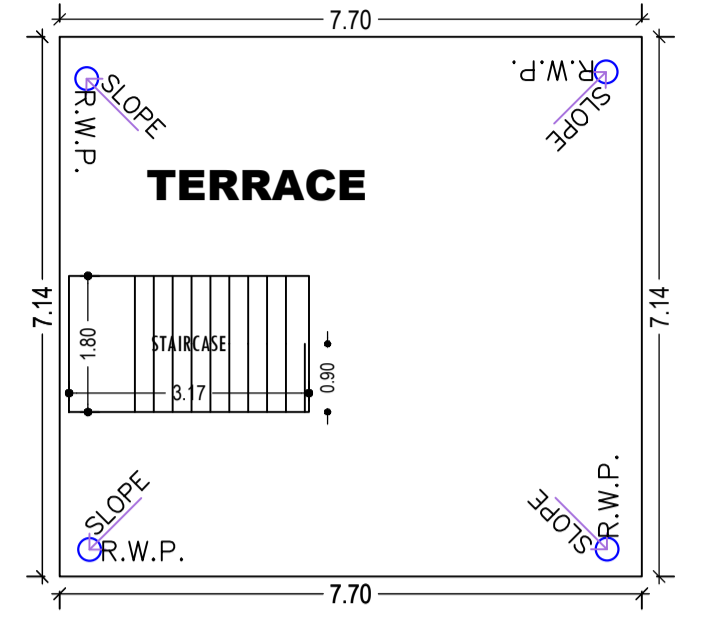

TERRACE FLOOR PLAN
SCALE 1:100

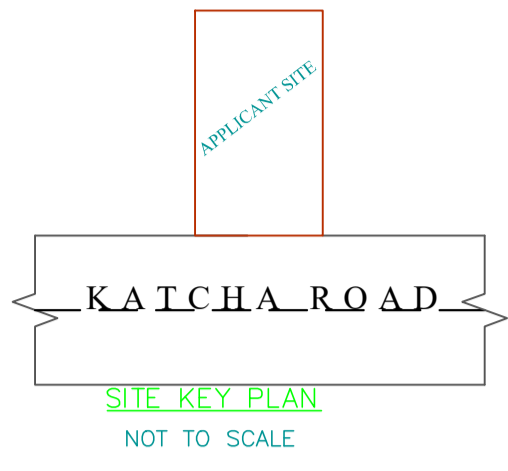

SITE KEY PLAN
NOT TO SCALE

FAR & Tenement Details (Table 4c-1)

Building	No. of Same Bldg	Total Built Up Area (Sq.mt.)	Deductions (Area in Sq.mt.)	Proposed FAR Area (Sq.mt.)	Total FAR Area (Sq.mt.)	Total Consumed Additional FAR Area (Sq.mt.)	Tnmt (No.)
AA (SMT SONI DEVI WO SRI PRADEEP KUMAR)	1	109.92	16.31	93.61	93.61	93.61	01
Grand Total :	1	109.92	16.31	93.61	93.61	93.61	01

Proposal Basic Information

Proposal File No.	JNP/IBP/0011/W01/2022
Owner Name	SMT SONI DEVI
Khata No	36
Plot No	64
Village Name	Nawada
Use	Residential
SubUse	Bungalow/ Dwelling / Non Apartment

AREA STATEMENT

Version No.:	1.0.62
Version Date:	16/10/2020
Region:	JHARKHAND URBAN LOCAL BODIES
District:	KODERMA
Authority:	JHUMRITILAIYA NAGAR PARISHAD
Inward No.:	JNP/IBP/0011/W01/2022
Application Type:	General Proposal
Project Type:	Building Permission
Nature of Development:	New
Location of Development Area:	Old Area
Plot Use:	Residential
Plot SubUse:	Bungalow/ Dwelling / Non Apartment
Plot Nearby/Religious Structure:	NA
Plot/SubPlot No.:	64
North:	LAND OF SMT POONAM DEVI
South:	LAND OF VENDOR
East:	Road Width - 2.75M WIDE KATCHA ROAD
West:	Plot No. - LAND OF SMT PUSHPA DEVI

AREA OF PLOT (Minimum) (A) 101.15 SQ.MT.

Deduction for NetPlot Area

Road Widening Area	7.75
Total	7.75

NET AREA OF PLOT(Gross Plot Area - Deduction from Gross Plot area) (A-Deductions) 93.40

Deduction for Balance Plot Area(from Gross Plot Area)

Road Widening Area	7.75
Total	7.75

Common Plot 12.59

Total 20.34

BALANCE AREA OF PLOT(Net Plot Area - Recreational/Amenity space) (A-Deductions) 80.81

PLOT AREA FOR COVERAGE(Net Plot Area) (A-Deductions) 93.40

Plot Area for FAR (Net Plot Area + RoadWidening Area) (A-Deductions) 93.40

COVERAGE CHECK

Permissible Coverage area (70.00 %)	65.38
Proposed Coverage Area (58.84 %)	54.96
Total Prop. Coverage Area (58.84 %)	54.96
Balance coverage area (11.16 %)	10.42

FAR CHECK

Perm. FAR Area (1.20)	112.08
Total Perm. FAR area	112.08
Residential FAR	93.61
Proposed FAR Area	93.61
Total Proposed FAR Area	93.61
Consumed FAR (Factor)	1.00
Balance FAR Area	18.47

BUILT UP AREA CHECK

Total Proposed BuiltUp Area	109.92
-----------------------------	--------

ARCHITECT (Regd) MD SHOAB ALAM

ENGINEER (Regd)

SUPERVISOR (Regd)

OWNER (Regd) SMT SONI DEVI

DEVELOPMENT AUTHORITY LOCAL BODY

SITE PLAN

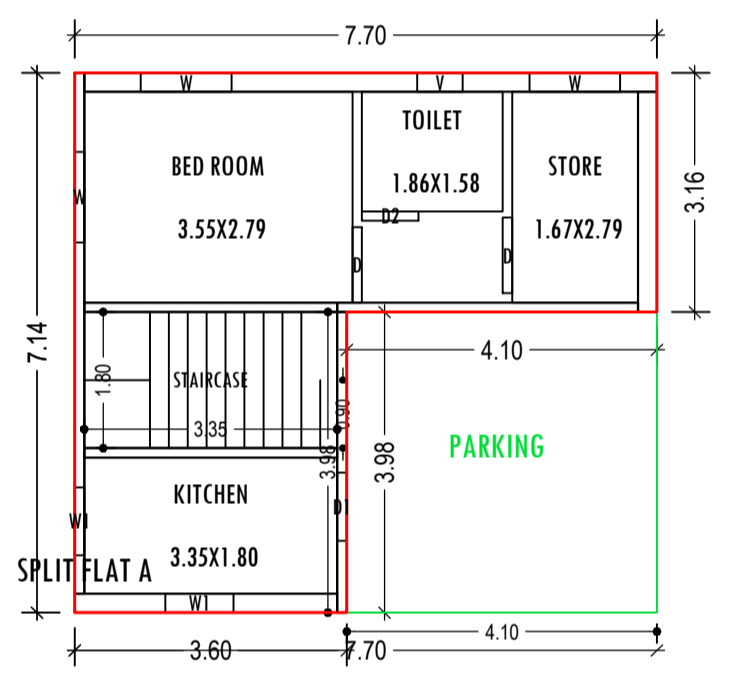

GROUND FLOOR PLAN
(Proposed)
SCALE 1:100

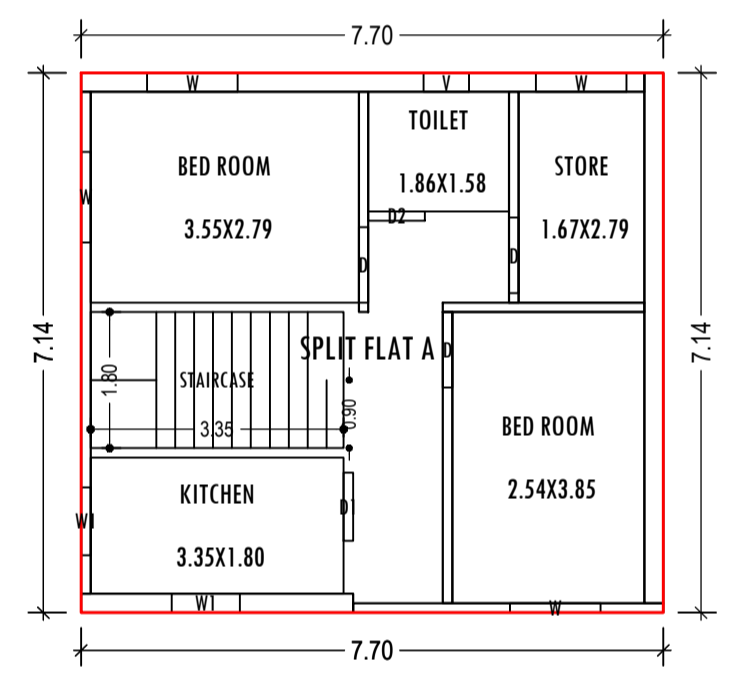

FIRST FLOOR PLAN
(Proposed)
SCALE 1:100

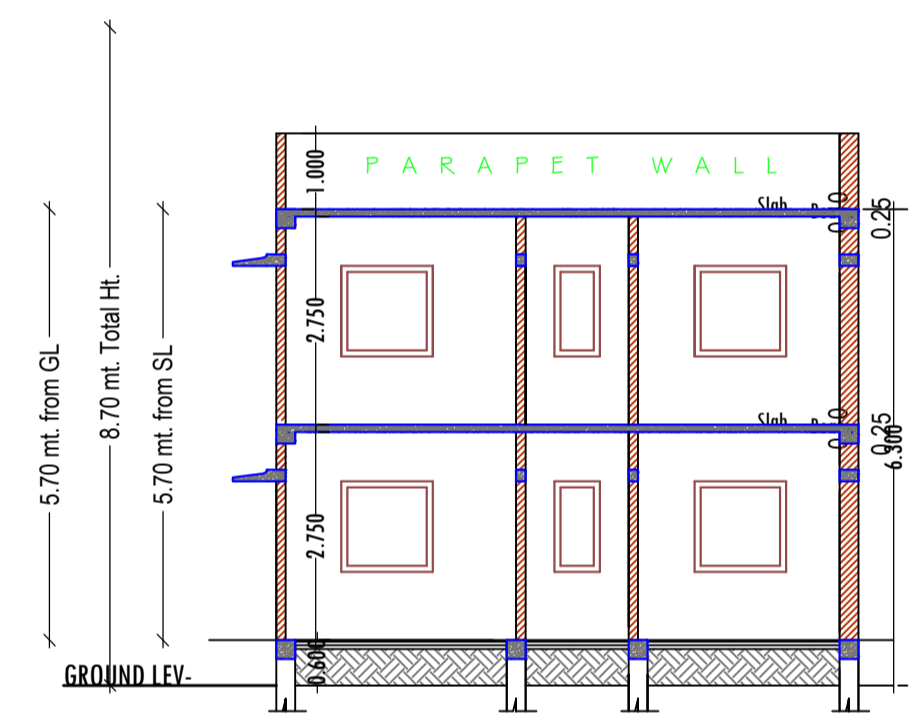

SECTION- Y,Y
SCALE :- 1=100

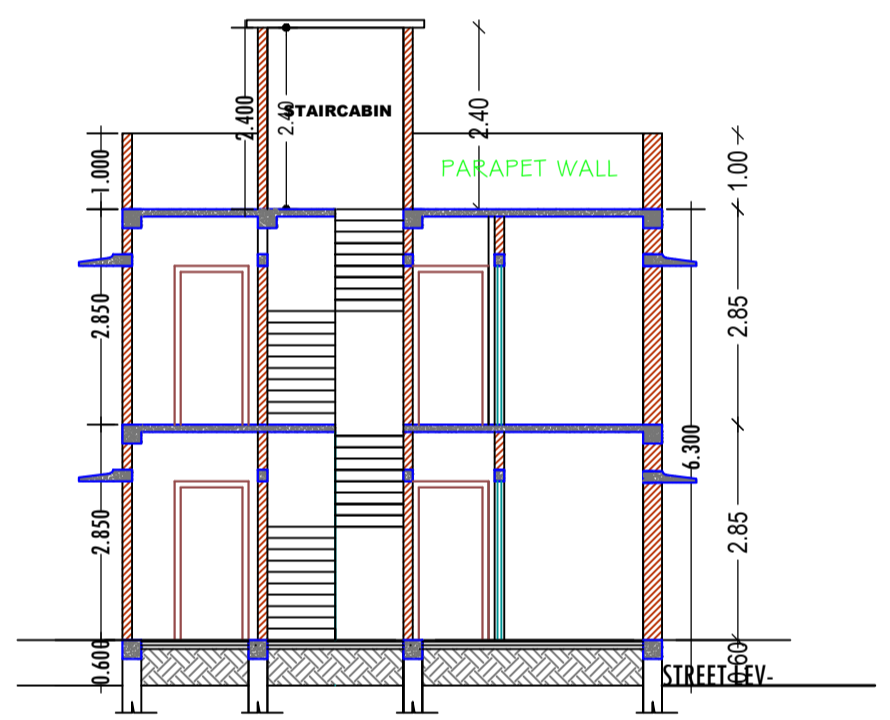

SECTION- X,X
SCALE :- 1=100

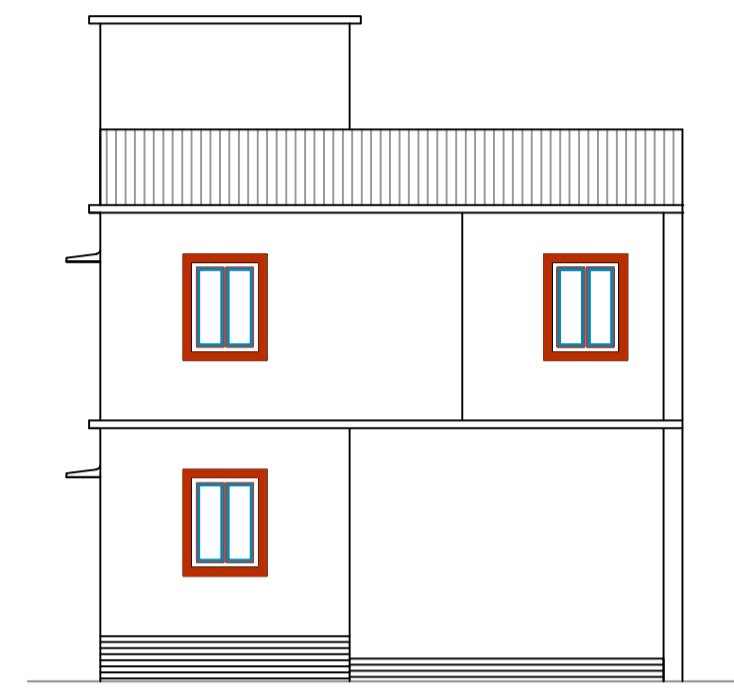
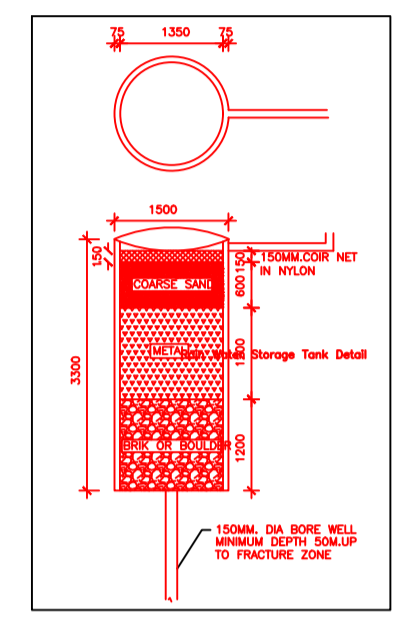

FRONT ELEVATION
SCALE - 1=100



SOUTH SIDE ELEVATION
SCALE - 1=100

COLOR INDEX

PLOT BOUNDARY	Black
ABUTTING ROAD	Red
PROPOSED CONSTRUCTION	Green
COMMON PLOT	Yellow
ROAD WIDENING AREA	Blue
EXISTING (To be retained)	Light Blue
EXISTING (To be demolished)	Light Yellow

Building :AA (SMT SONI DEVI WO SRI PRADEEP KUMAR)

Floor Name	Total Built Up Area (Sq.mt.)	Deductions (Area in Sq.mt.)	Proposed FAR Area (Sq.mt.)	Total FAR Area (Sq.mt.)	Total Consumed Additional FAR Area (Sq.mt.)	Tnmt (No.)
Ground Floor	54.96	16.31	38.65	38.65	38.65	01
First Floor	54.96	0.00	54.96	54.96	54.96	00
Terrace Floor	0.00	0.00	0.00	0.00	0.00	00
Total :	109.92	16.31	93.61	93.61	93.61	01
Total Number of Same Buildings	1					
Total :	109.92	16.31	93.61	93.61	93.61	01

SCHEDULE OF DOOR:

BUILDING NAME	NAME	LENGTH	HEIGHT	NOS
AA (SMT SONI DEVI WO SRI PRADEEP KUMAR)	D2	0.75	1.20	02
AA (SMT SONI DEVI WO SRI PRADEEP KUMAR)	D1	0.90	2.13	02
AA (SMT SONI DEVI WO SRI PRADEEP KUMAR)	D	1.00	2.13	05

SCHEDULE OF WINDOW/VENTILATION:

BUILDING NAME	NAME	LENGTH	HEIGHT	NOS
AA (SMT SONI DEVI WO SRI PRADEEP KUMAR)	V	0.60	0.60	02
AA (SMT SONI DEVI WO SRI PRADEEP KUMAR)	W1	0.90	1.20	04
AA (SMT SONI DEVI WO SRI PRADEEP KUMAR)	W	1.20	1.20	07

UnitBUA Table for Building :AA (SMT SONI DEVI WO SRI PRADEEP KUMAR)

FLOOR	Name	UnitBUA Type	UnitBUA Area	Carpet Area	No. of Rooms	No. of Tenement
GROUND FLOOR PLAN	SPLIT FLAT A	FLAT	76.16	73.80	4	1
FIRST FLOOR PLAN	SPLIT FLAT A	FLAT	0.00	0.00	5	0
Total:	-	-	76.16	73.80	9	1

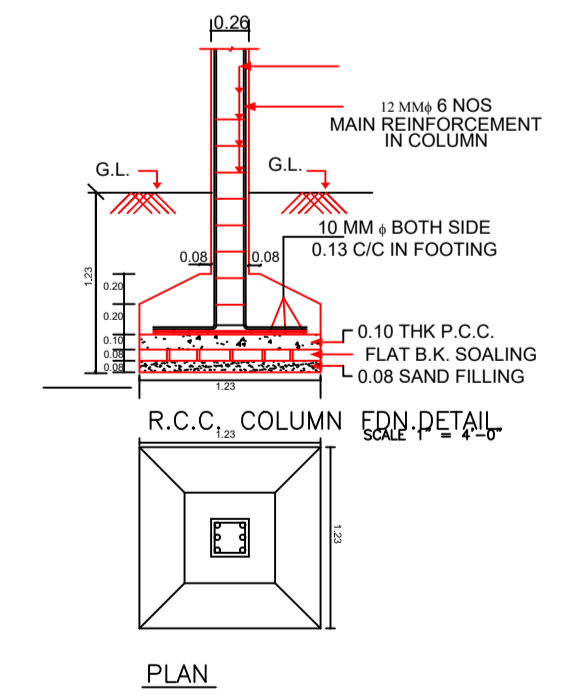
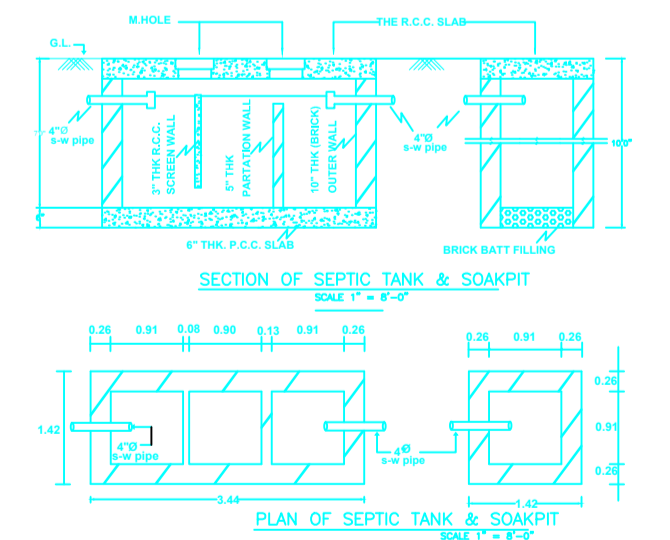

Buildingwise Floor FAR Details

Floor Name	Building Name		Total	
	Proposed Built Up Area (Sq.mt.)	Proposed FAR Area (Sq.mt.)	Total Proposed Built Up Area (Sq.mt.)	Total FAR Area (Sq.mt.)
Ground Floor	54.96	38.65	54.96	38.65
First Floor	54.96	54.96	54.96	54.96
Terrace Floor	0.00	0.00	0.00	0.00
Total :	109.92	93.61	109.92	93.61

Building USE/SUBUSE Details

Building Name	Building Use	Building SubUse	Building Structure
AA (SMT SONI DEVI WO SRI PRADEEP KUMAR)	Residential	Bungalow/ Dwelling / Non Apartment	Non-Highrise

LTP NAME AND SIGNATURE	STRUCTURAL ENG'S NAME AND SIGNATURE	BUILDER NAME AND SIGNATURE	DIGITAL SIGNATURE
MD SHOAB ALAM JNP/ENG/001/2017			