

FAR & Tenement Details (Table 4c-1)

Building	No. of Same Bldg	Total Built Up Area (Sq.mt.)	Deductions (Area in Sq.mt.)		Proposed FAR Area (Sq.mt.)		Add Area In FAR (Sq.mt.)	Total FAR Area (Sq.mt.)	Total Consumed Additional FAR Area (Sq.mt.)	Trnmt (No.)
			Void	Parking	Resi.	Stair				
A (RESIDENTIAL)	1	245.37	8.21	50.72	175.82	10.62	186.44	186.44	01	
Grand Total	1	245.37	8.21	50.72	175.82	10.62	186.44	186.44	01	

Proposal Basic Information

Proposal File No.	JNP/BP/0025/W14/2022
Owner Name	SRI MAHENDRA SINGH SONI
Khata No	381
Plot No	7160
Village Name	Tilaiya
Use	Residential
SubUse	Bungalow/ Dwelling / Non Apartment

AREA STATEMENT

AREA OF PLOT (Minimum)	(A)	SQ.MT.
NET AREA OF PLOT (Gross Plot Area - Deduction from Gross Plot area)	(A-Deductions)	104.85
Deduction for Balance Plot Area (from Gross Plot Area)		
Common Plot		12.95
BALANCE AREA OF PLOT (Net Plot Area - Recreational/Amenity space)	(A-Deductions)	91.90
PLOT AREA FOR COVERAGE (Net Plot Area)	(A-Deductions)	104.85
Plot Area for FAR (Net Plot Area + Road Widening Area)	(A-Deductions)	104.85

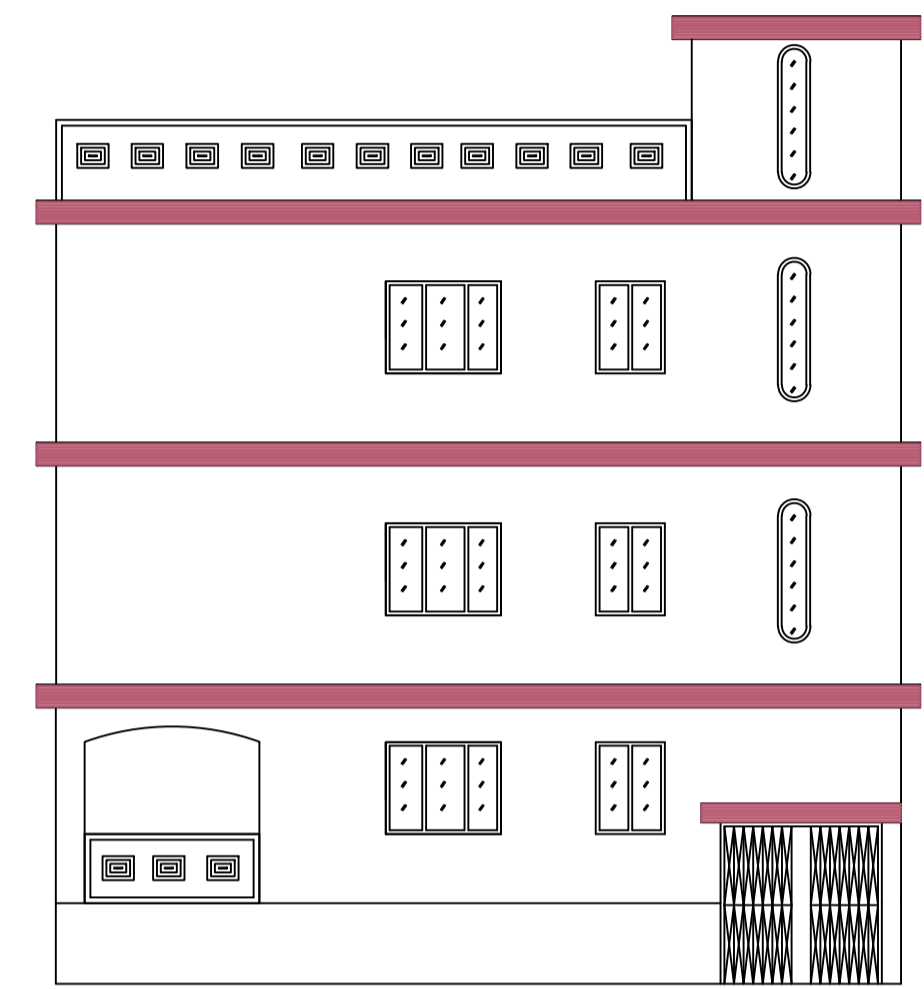

COVERAGE CHECK

Permissible Coverage area (70.00 %)	73.39
Proposed Coverage Area (58.50 %)	61.34
Total Prop. Coverage Area (58.5 %)	61.34
Balance coverage area (11.49 %)	12.05

FAR CHECK

Perm. FAR Area (1.80)	188.73
Total Perm. FAR area	188.73
Residential FAR	175.82
Proposed FAR Area	186.44
Total Proposed FAR Area	186.44
Consumed FAR (Factor)	1.78
Balance FAR Area	2.29

COLOR INDEX

PLOT BOUNDARY	Black
ABUTTING ROAD	Green
PROPOSED CONSTRUCTION	Red
COMMON PLOT	Yellow
ROAD WIDENING AREA	Blue
EXISTING (To be retained)	Light Blue
EXISTING (To be demolished)	White

SITE PLAN

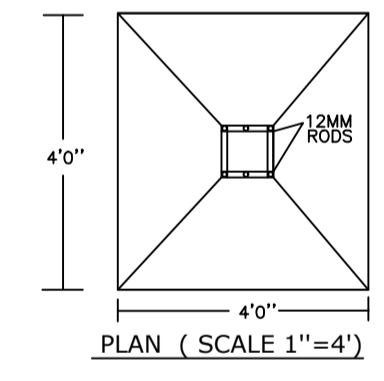
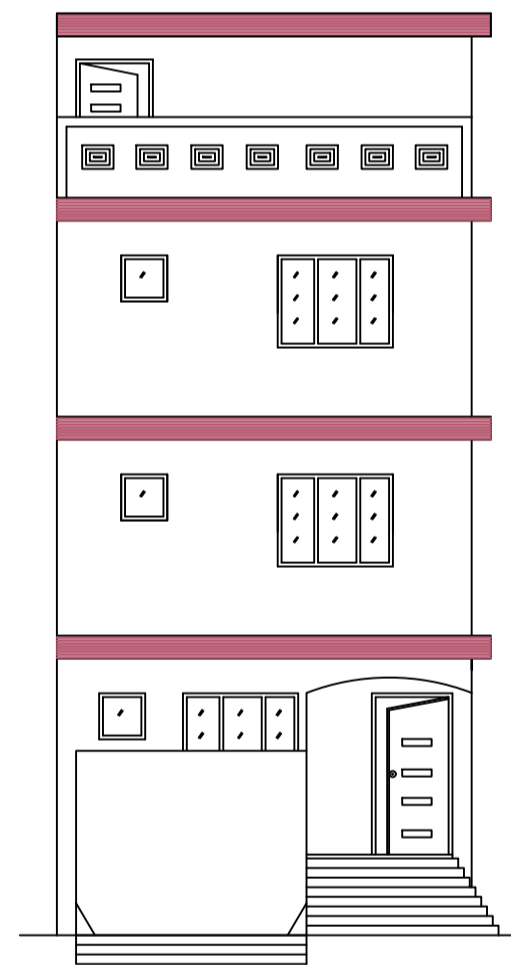
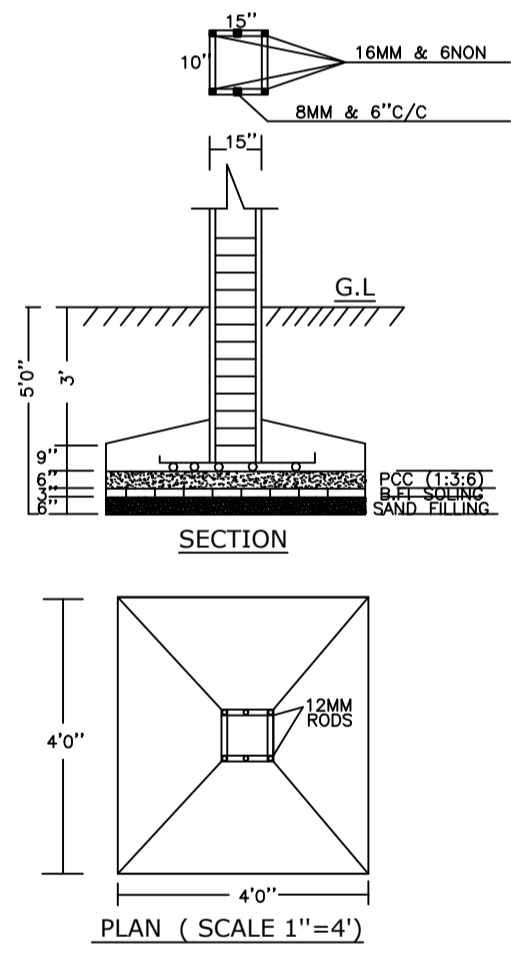
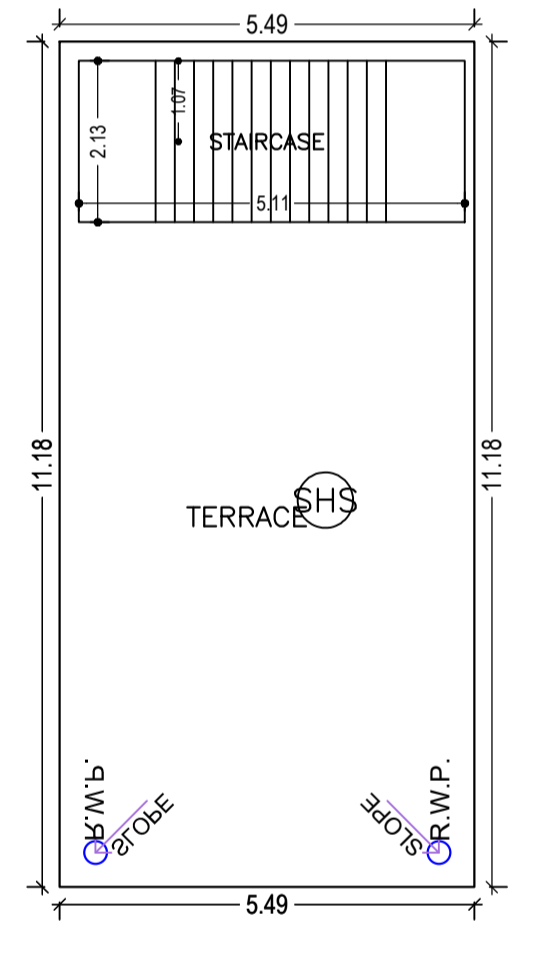
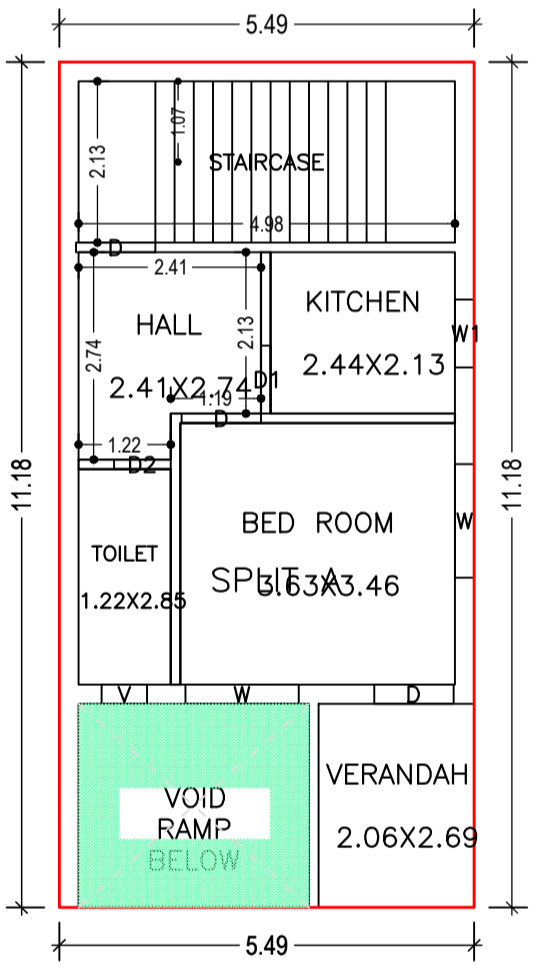
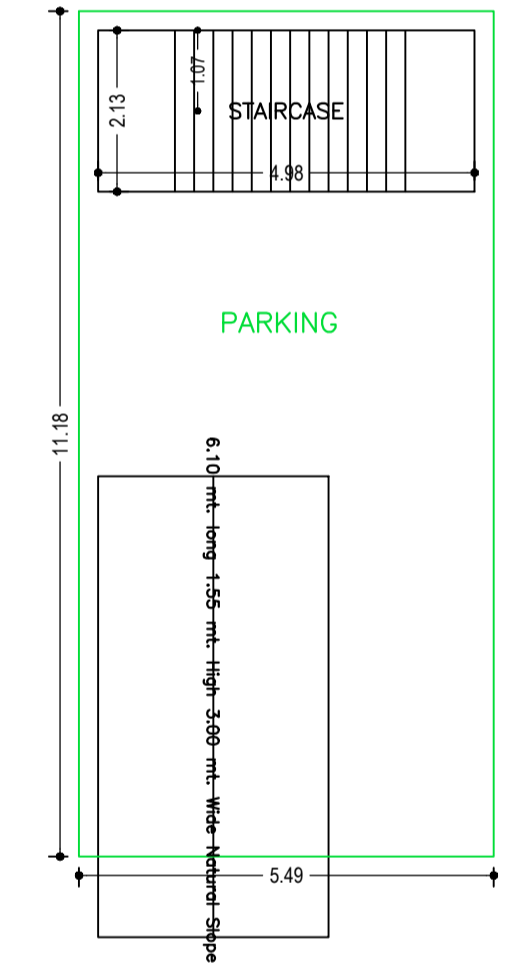

Buildingwise Floor FAR Details

Floor Name	Building Name A (RESIDENTIAL)		Total	
	Proposed Built Up Area (Sq.mt.)	Proposed FAR Area (Sq.mt.)	Total Proposed Built Up Area (Sq.mt.)	Total FAR Area (Sq.mt.)
Basement Floor	61.34	10.62	61.34	10.62
Ground Floor	61.35	53.14	61.35	53.14
First Floor	61.34	61.34	61.34	61.34
Second Floor	61.34	61.34	61.34	61.34
Terrace Floor	0.00	0.00	0.00	0.00
Total :	245.37	186.44	245.37	186.44

Building USE/SUBUSE Details

Building Name	Building Use	Building SubUse	Building Structure
A (RESIDENTIAL)	Residential	Bungalow/ Dwelling / Non Apartment	Non-Highrise

Building : A (RESIDENTIAL)

Floor Name	Total Built Up Area (Sq.mt.)	Deductions (Area in Sq.mt.)		Proposed FAR Area (Sq.mt.)		Add Area In FAR (Sq.mt.)	Total FAR Area (Sq.mt.)	Total Consumed Additional FAR Area (Sq.mt.)	Trnmt (No.)
		Void	Parking	Resi.	Stair				
Basement Floor	61.34	0.00	0.00	50.72	10.62	10.62	10.62	00	
Ground Floor	61.35	8.21	0.00	53.14	0.00	53.14	53.14	01	
First Floor	61.34	0.00	0.00	61.34	0.00	61.34	61.34	00	
Second Floor	61.34	0.00	0.00	61.34	0.00	61.34	61.34	00	
Terrace Floor	0.00	0.00	0.00	0.00	0.00	0.00	0.00	00	
Total :	245.37	8.21	50.72	175.82	10.62	186.44	186.44	01	

SCHEDULE OF DOOR:

BUILDING NAME	NAME	LENGTH	HEIGHT	NOS
A (RESIDENTIAL)	D2	0.75	2.10	03
A (RESIDENTIAL)	D1	0.90	2.10	03
A (RESIDENTIAL)	D	1.05	2.10	09

SCHEDULE OF WINDOW/VENTILATION:

BUILDING NAME	NAME	LENGTH	HEIGHT	NOS
A (RESIDENTIAL)	V	0.60	0.75	03
A (RESIDENTIAL)	W1	0.90	1.20	03
A (RESIDENTIAL)	W	1.50	1.20	06

UnitBUA Table for Building :A (RESIDENTIAL)

FLOOR	Name	UnitBUA Type	UnitBUA Area	Carpet Area	No. of Rooms	No. of Tenement
GROUND FLOOR PLAN	SPLIT A	FLAT	118.23	112.74	5	1
TYPICAL - 1 & 2 FLOOR PLAN	SPLIT A	FLAT	0.00	0.00	5	0
Total:	-	-	118.23	112.74	15	1

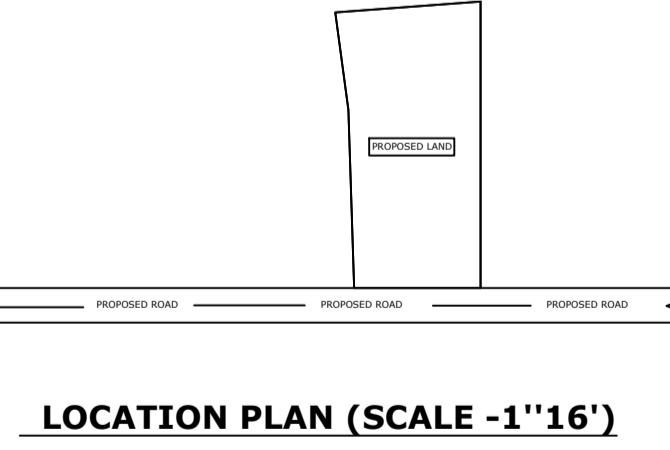

LTP NAME AND SIGNATURE	STRUCTURAL ENG'S NAME AND SIGNATURE	BUILDER NAME AND SIGNATURE	DIGITAL SIGNATURE
KIRAN KUMARI JNP/ENG/001/2019			