

Proposal Basic Information

Proposal File No.	JNP/IBP/0003/W22/2022
Owner Name	(1) DR PRITI BARNWAL (2) DR. JITENDRA KUMAR
Khata No	99
Plot No	1092
Village Name	Gomo
Use	Residential
SubUse	Bungalow/ Dwelling / Non Apartment

FAR & Tenement Details (Table 4c-1)

Building	No. of Same Bldg	Total Built Up Area (Sq.mt.)	Deductions (Area in Sq.mt.)			Proposed FAR Area (Sq.mt.)	Add Area In FAR (Sq.mt.)	Total FAR Area (Sq.mt.)	Total Consumed Additional FAR Area (Sq.mt.)	Trmnt (No.)
			Lift	Accessory Use	Parking					
A (APARTMENT)	1	1436.05	12.92	40.92	272.28	1098.23	11.71	1109.94	1109.94	08
Grand Total	1	1436.05	12.92	40.92	272.28	1098.23	11.71	1109.94	1109.94	08

Required Parking (Table 7a)

Building Name	Type	SubUse	Area (Sq.mt.)	Units		Car		Visitors Car		TwoWheeler		
				Reqd.	Prop.	Reqd./Unit	Prop.	Reqd./Unit	Prop.	Reqd./Unit	Prop.	
A (APARTMENT)	Residential	Bungalow/ Dwelling / Non Apartment	> 0	1	8.00	1	8	-	-	-	-	-
			> 0	1	8.00	-	-	1	1	-	-	-
			Total :	-	-	-	8	8	-	1	1	-

Parking Check (Table 7b)

Vehicle Type	Reqd.		Prop.	
	No.	Area	No.	Area
Car	-	-	8	100.00
Total Car	8	100.00	8	100.00
Visitor's Car Parking	-	-	1	12.76
Total Visitor Parking	1	12.50	1	12.76
TwoWheeler	-	-	14	28.00
Total TwoWheeler	-	-	14	28.00
Other Parking	-	-	-	181.78
Total	-	112.50	-	350.54

AREA STATEMENT	VERSION NO. : 1.0.62		
JHUMRITILAIYA NAGAR PARISHAD	VERSION DATE: 16/10/2020		
PROJECT DETAIL:			
Region: JHARKHAND URBAN LOCAL BODIES	Plot Use: Residential		
District: KODERMA	Plot SubUse: Bungalow/ Dwelling / Non Apartment		
Authority: JHUMRITILAIYA NAGAR PARISHAD	PlotNearby/ReligiousStructure: NA		
Inward No: JNP/IBP/0003/W22/2022	PlotSubPlot No: 1092		
Application Type: General Proposal	North: Plot No. - LAND OF SMT DROPADI DEVI		
Project Type: Building Permission	South: Plot No. - LAND OF TASHU KUMHAR		
Nature of Development: New	East: Plot No. - SRI RAMESHWAR BARNWAL		
Location of Development Area: Old Area	West: Road Width - 21.33		
AREA DETAILS:			
AREA OF PLOT (Minimum)	(A)	SQ.MT.	647.63
NET AREA OF PLOT (Gross Plot Area - Deduction from Gross Plot area)	(A-Deductions)		647.63
Deduction for Balance Plot Area (from Gross Plot Area)			
Total			70.86
BALANCE AREA OF PLOT (Net Plot Area - Recreational/Amenity space)	(A-Deductions)		576.76
PLOT AREA FOR COVERAGE (Net Plot Area)	(A-Deductions)		647.63
Plot Area for FAR (Net Plot Area + Road Widening Area)	(A-Deductions)		647.63
COVERAGE CHECK			
Permissible Coverage area (60.00 %)			388.58
Proposed Coverage Area (44.35 %)			287.21
Total Prop. Coverage Area (44.35 %)			287.21
Balance coverage area (15.65 %)			101.37
FAR CHECK			
Perm. FAR Area (2.00)			1295.26
Total Perm. FAR area			1295.26
Residential FAR			1098.24
Proposed FAR Area			1109.94
Total Proposed FAR Area			1109.94
Consumed FAR (Factor)			1.71
Balance FAR Area			185.32
BUILT UP AREA CHECK			
Total Proposed BuiltUp Area			1436.05
ARCHITECT (Regd)			KIRAN KUMARI
ENGINEER (Regd)			
SUPERVISOR (Regd)			
OWNER (Regd)			(1) DR PRITI BARNWAL (2) DR. JITENDRA KUMAR
DEVELOPMENT AUTHORITY		LOCAL BODY	

COLOR INDEX	
PLOT BOUNDARY	Black
ABUTTING ROAD	Green
PROPOSED CONSTRUCTION	Red
COMMON PLOT	Yellow
ROAD WIDENING AREA	Blue
EXISTING (To be retained)	Light Blue
EXISTING (To be demolished)	Orange

Buildingwise Floor FAR Details

Floor Name	Building Name A (APARTMENT)		Total	
	Proposed Built Up Area (Sq.mt.)	Proposed FAR Area (Sq.mt.)	Total Proposed Built Up Area (Sq.mt.)	Total FAR Area (Sq.mt.)
Basement Floor	287.21	11.71	287.21	11.71
Ground Floor	287.21	276.98	287.21	276.98
First Floor	287.21	273.75	287.21	273.75
Second Floor	287.21	273.75	287.21	273.75
Third Floor	287.21	273.75	287.21	273.75
Terrace Floor	0.00	0.00	0.00	0.00
Total :	1436.05	1109.94	1436.05	1109.94

Building USE/SUBUSE Details

Building Name	Building Use	Building SubUse	Building Structure
A (APARTMENT)	Residential	Bungalow/ Dwelling / Non Apartment	Non-Highrise

LTP NAME AND SIGNATURE	STRUCTURAL ENG'S NAME AND SIGNATURE	BUILDER NAME AND SIGNATURE	DIGITAL SIGNATURE
KIRAN KUMARI JNP/ENG/0001/2019			

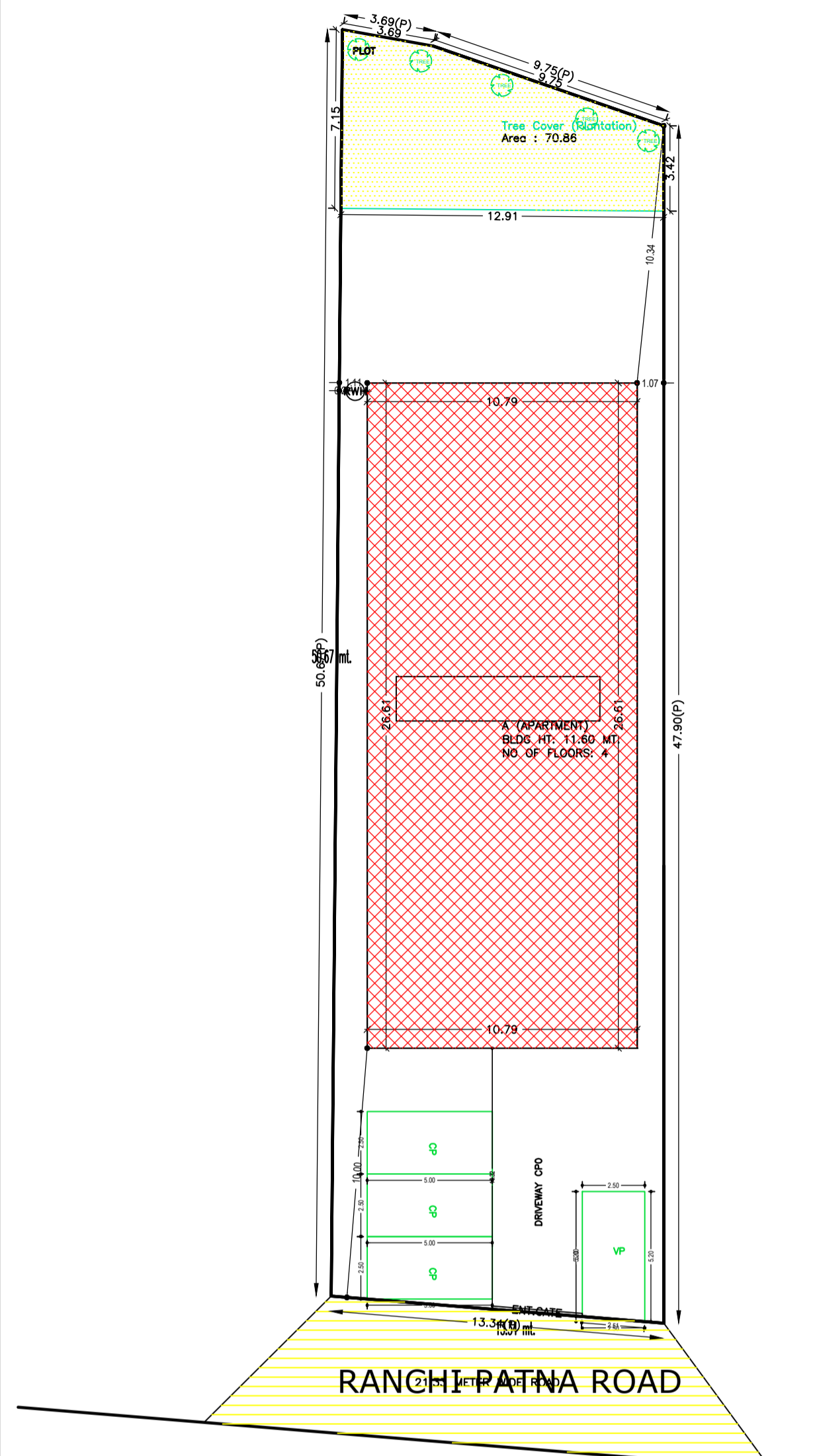

SITE PLAN (Scale - 1:200)

Proposal Basic Information	
Proposal File No.	JNP/IBP/0003/W22/2022
Owner Name	(1) DR PRITI BARNWAL (2) DR. JITENDRA KUMAR
Khata No	99
Plot No	1092
Village Name	Gomo
Use	Residential
SubUse	Bungalow/ Dwelling / Non Apartment

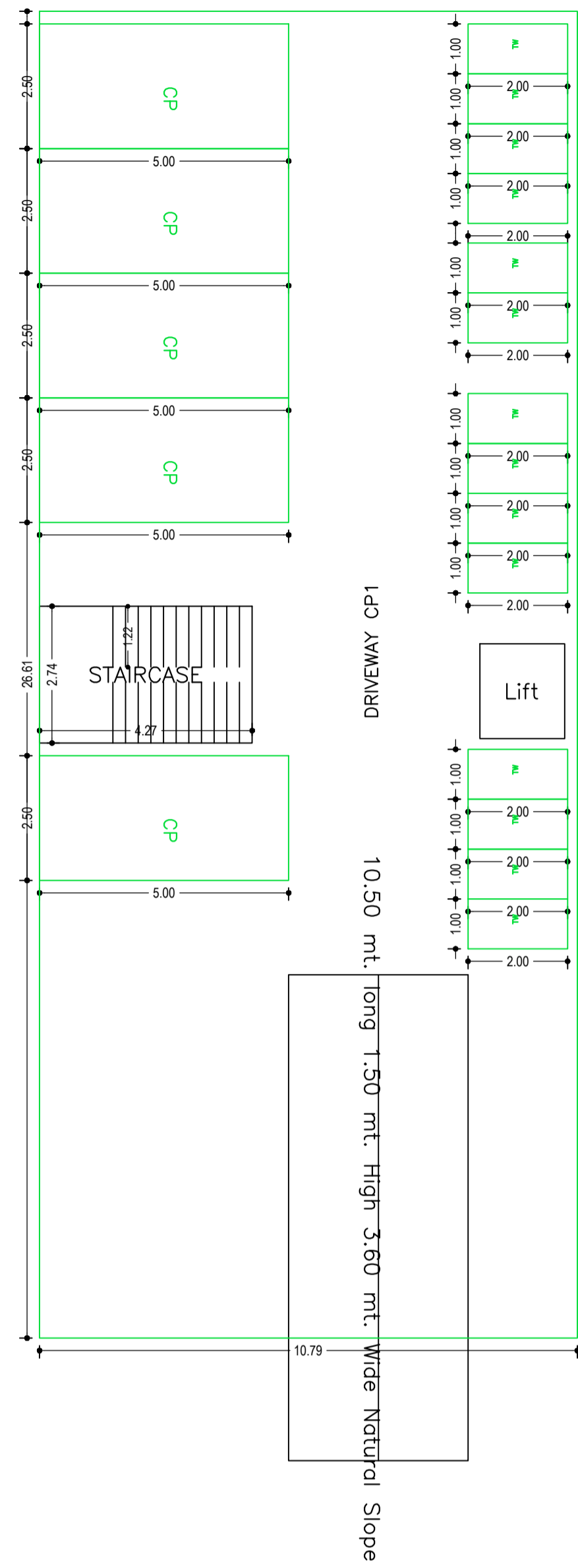

BASEMENT FLOOR PLAN (SCALE 1:100)

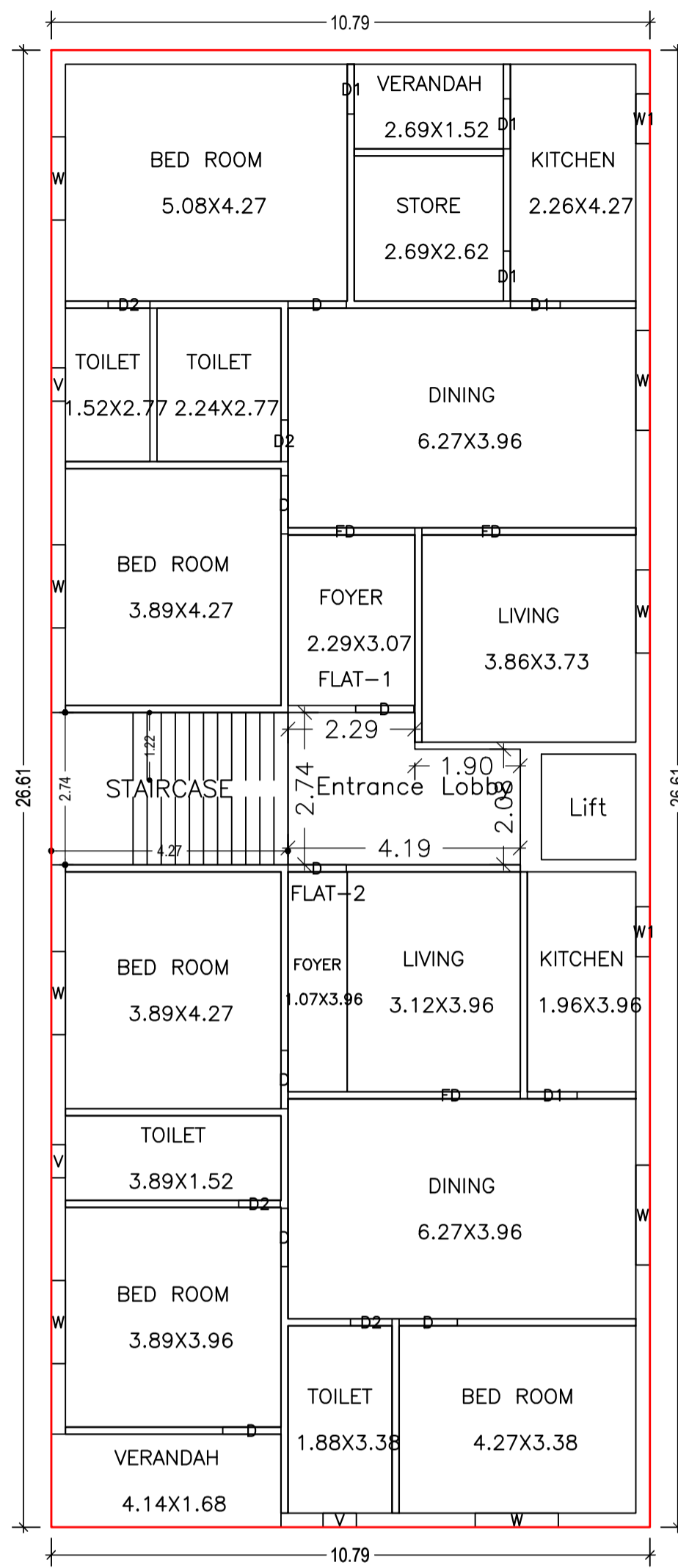

GROUND FLOOR PLAN (Proposed) (SCALE 1:100)

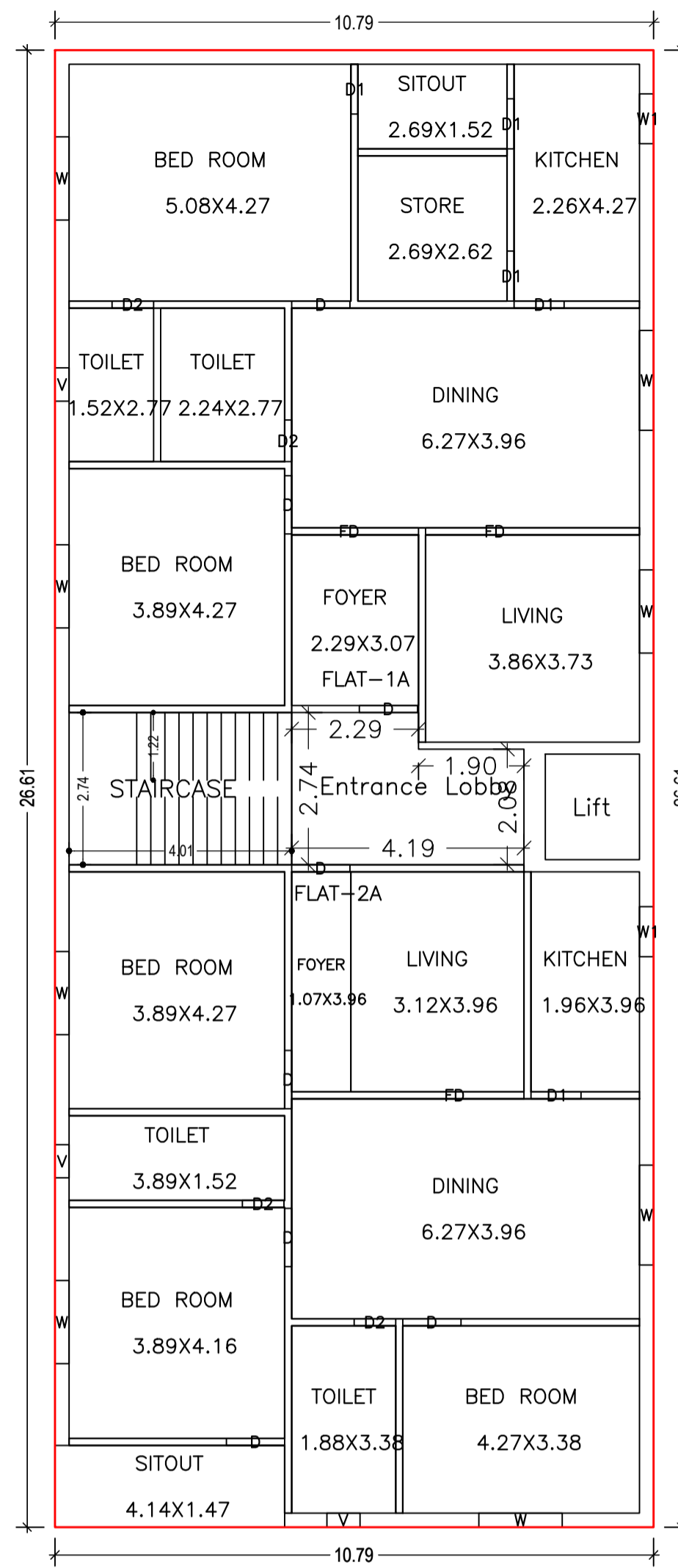

TYPICAL - 1- 3 FLOOR PLAN (Proposed) (SCALE 1:100)

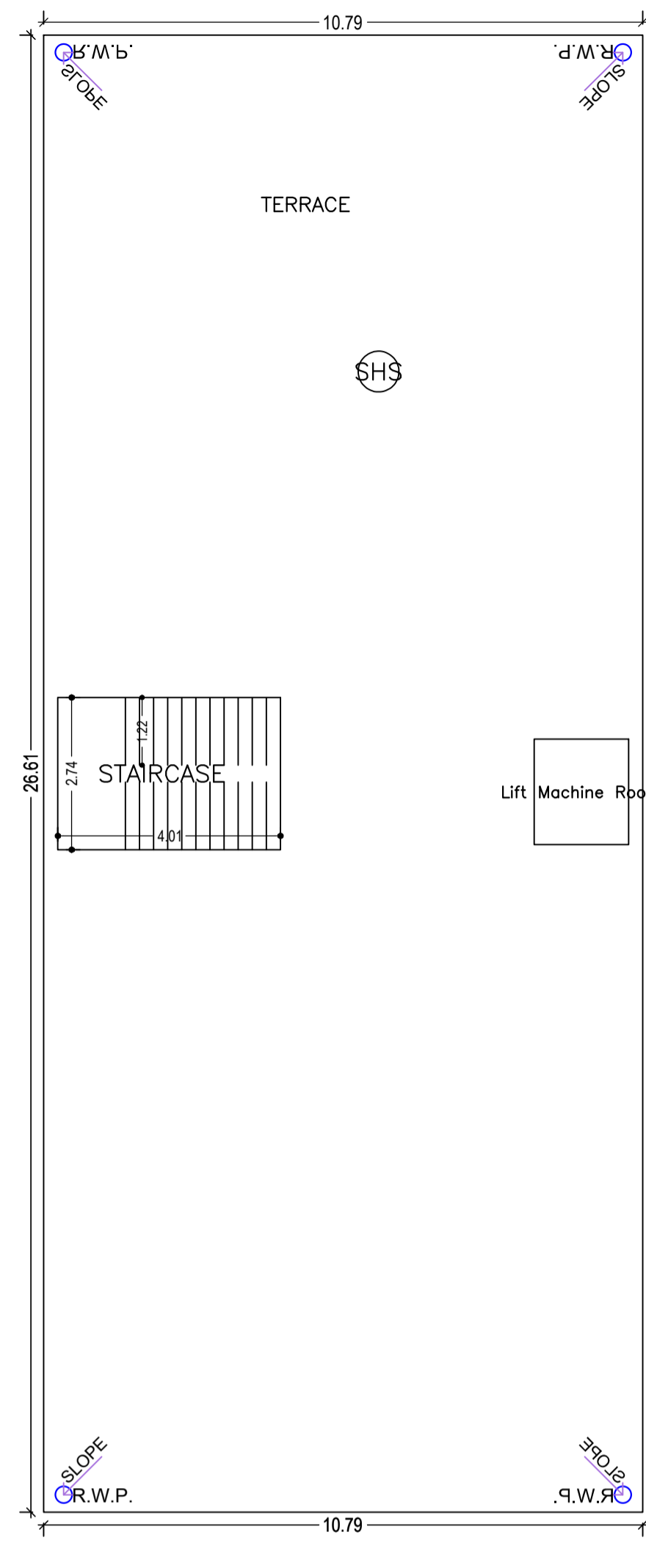

TERRACE FLOOR PLAN (SCALE 1:100)

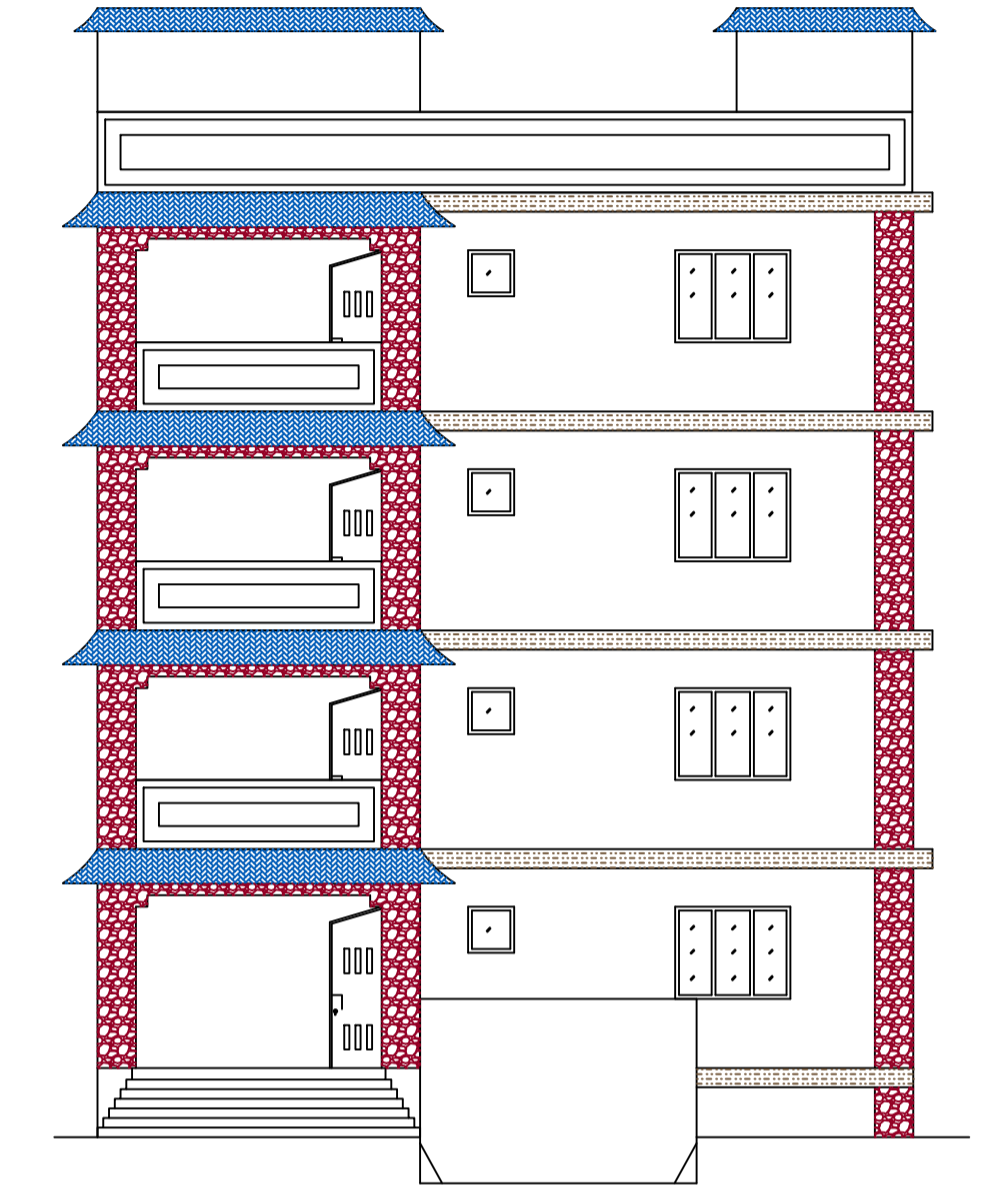
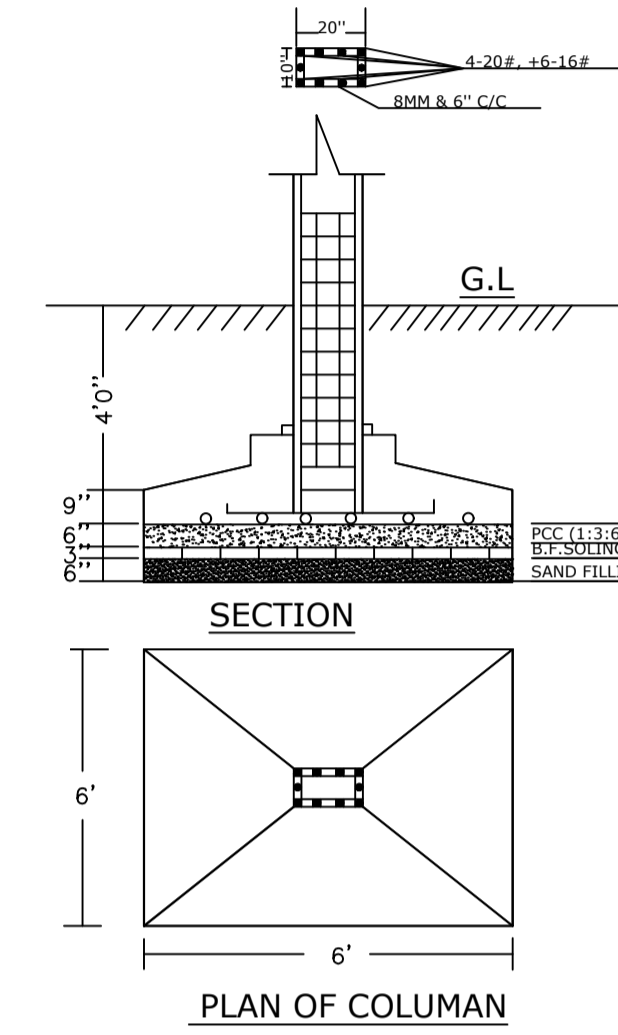

FRONT ELEVATION

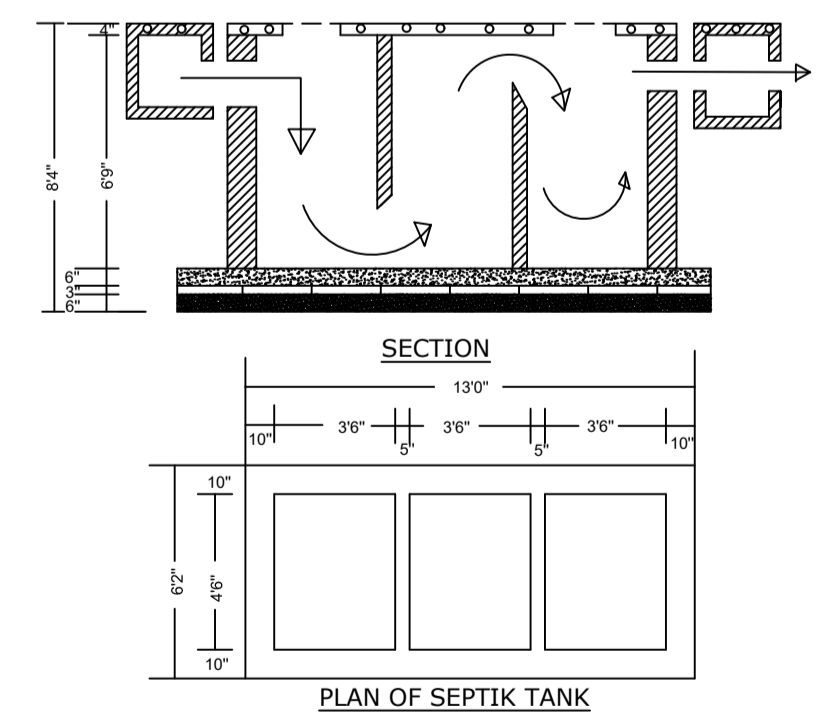
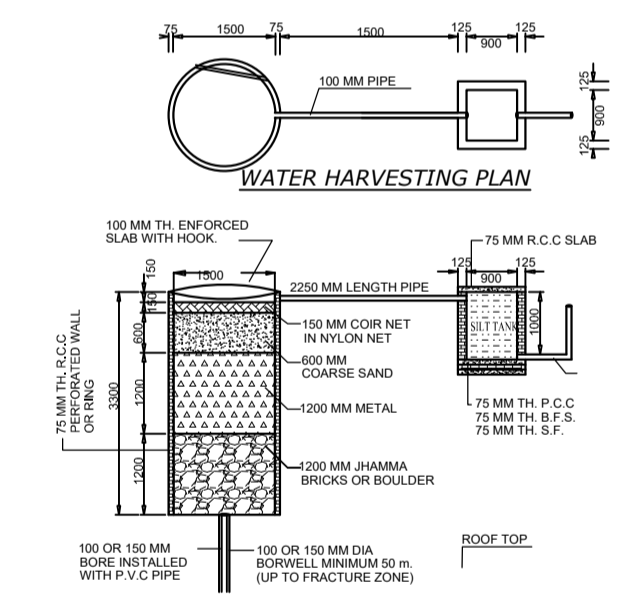

Building :A (APARTMENT)

Floor Name	Total Built Up Area (Sq.mt.)	Deductions (Area in Sq.mt.)			Proposed FAR Area (Sq.mt.)	Add Area in FAR (Sq.mt.)	Total FAR Area (Sq.mt.)	Total Consumed Additional FAR Area (Sq.mt.)	Trmt (No.)
		Lift	Accessory Use	Parking					
Basement Floor	287.21	3.23	0.00	272.28	0.00	11.71	11.71	11.71	00
Ground Floor	287.21	0.00	10.23	0.00	276.98	0.00	276.98	276.98	02
First Floor	287.21	3.23	10.23	0.00	273.75	0.00	273.75	273.75	02
Second Floor	287.21	3.23	10.23	0.00	273.75	0.00	273.75	273.75	02
Third Floor	287.21	3.23	10.23	0.00	273.75	0.00	273.75	273.75	02
Terrace Floor	0.00	0.00	0.00	0.00	0.00	0.00	0.00	0.00	00
Total :	1436.05	12.92	40.92	272.28	1098.23	11.71	1109.94	1109.94	08
Total Number of Same Buildings :	1								
Total :	1436.05	12.92	40.92	272.28	1098.23	11.71	1109.94	1109.94	08

SCHEDULE OF DOOR:

BUILDING NAME	NAME	LENGTH	HEIGHT	NOS
A (APARTMENT)	D2	0.75	2.10	16
A (APARTMENT)	D1	0.90	2.10	20
A (APARTMENT)	D	1.05	2.10	32
A (APARTMENT)	FD	2.29	2.75	04
A (APARTMENT)	FD	3.86	2.75	04
A (APARTMENT)	FD	4.19	2.75	04

SCHEDULE OF WINDOW/VENTILATION:

BUILDING NAME	NAME	LENGTH	HEIGHT	NOS
A (APARTMENT)	V	0.60	1.00	12
A (APARTMENT)	W1	0.90	1.20	08
A (APARTMENT)	W	1.50	1.20	24
A (APARTMENT)	W	1.80	1.50	08

UnitBUA Table for Building :A (APARTMENT)

FLOOR	Name	UnitBUA Type	UnitBUA Area	Carpet Area	No. of Rooms	No. of Tenement
GROUND FLOOR PLAN	FLAT-1	FLAT	122.26	116.34	10	2
TYPICAL - 1- 3 FLOOR PLAN	FLAT-1A	FLAT	122.26	116.34	10	6
Total:	-	-	973.97	924.26	80	8

LTP NAME AND SIGNATURE	STRUCTURAL ENG'S NAME AND SIGNATURE	BUILDER NAME AND SIGNATURE	DIGITAL SIGNATURE
KIRAN KUMARI JNP/ENG/0001/2019			

Proposal Basic Information	
Proposal File No.	JNP/IBP/0003/W22/2022
Owner Name	(1) DR PRITI BARNWAL (2) DR. JITENDRA KUMAR
Khata No	99
Plot No	1092
Village Name	Gomo
Use	Residential
SubUse	Bungalow/ Dwelling / Non Apartment

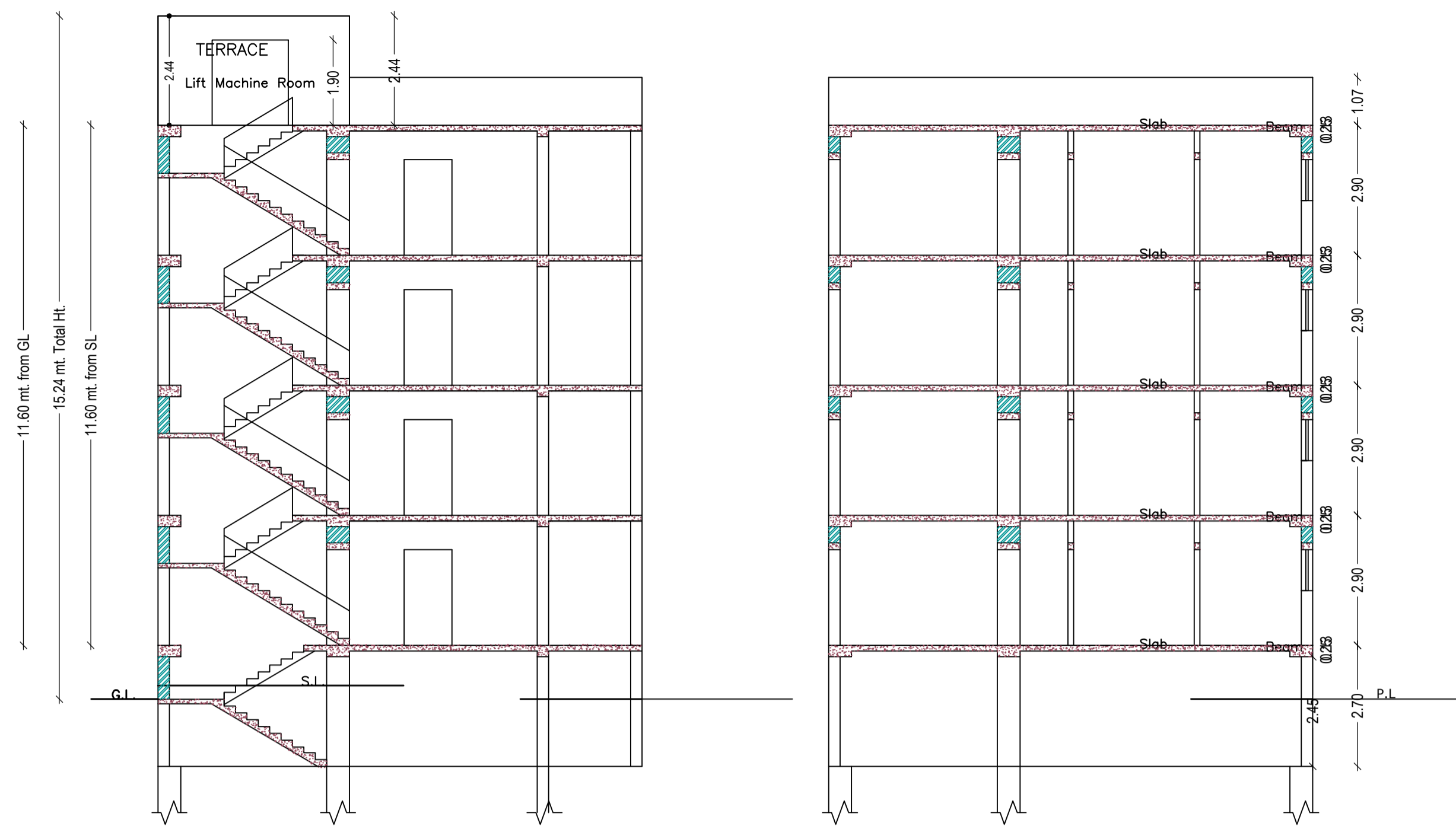

CROSS SECTION (A)

CROSS SECTION (B)

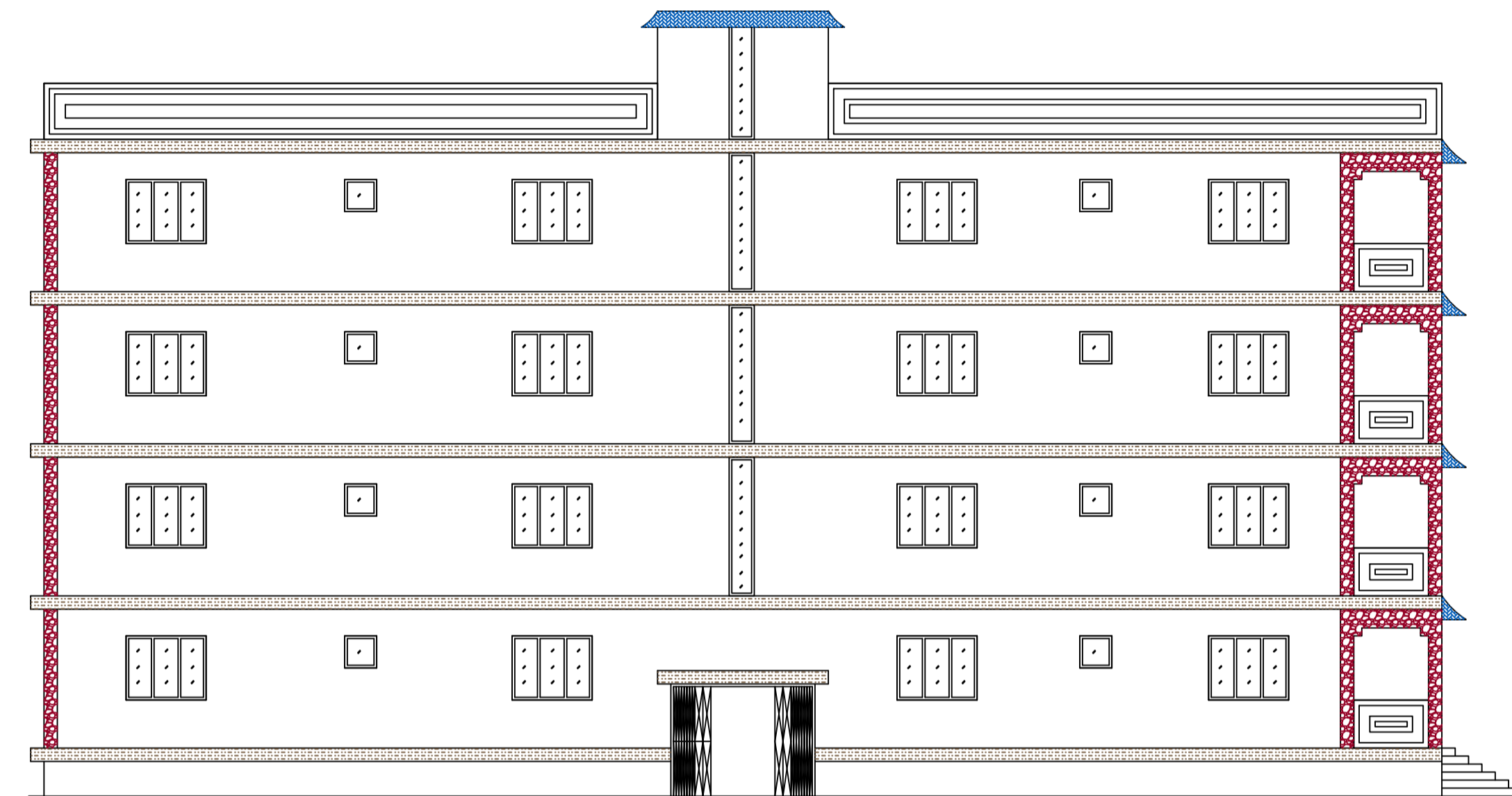

CROSS ELEVATION

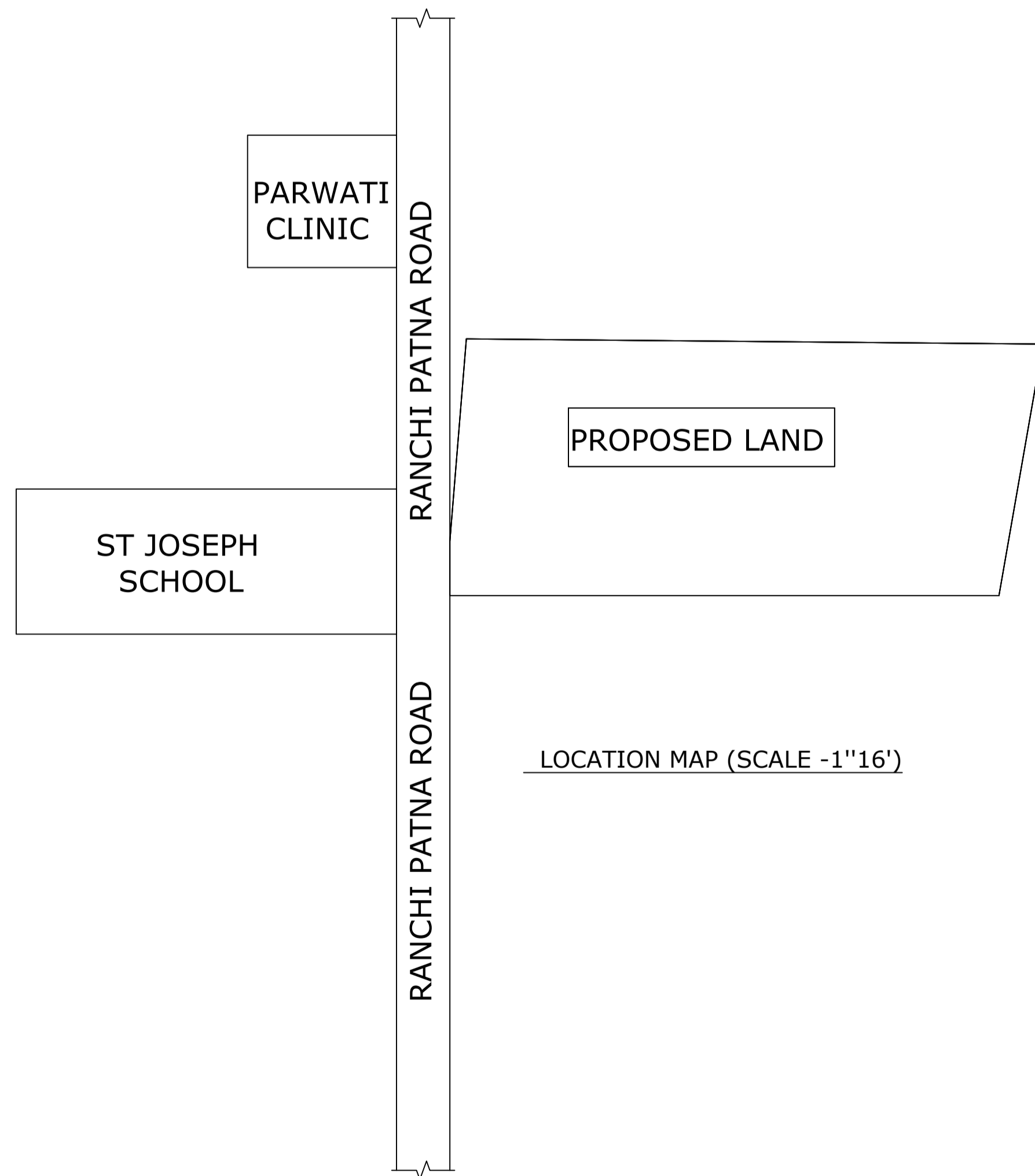

LOCATION MAP (SCALE -1"16')

LTP NAME AND SIGNATURE	STRUCTURAL ENG'S NAME AND SIGNATURE	BUILDER NAME AND SIGNATURE	DIGITAL SIGNATURE
KIRAN KUMARI JNP/ENG/0001/2019			