

Proposal Basic Information

Proposal File No.	JNP/IBP/0006/W07/2022
Owner Name	SMT. RADHA DEVI
Khata No	02
Plot No	291
Village Name	Jhalpo
Use	Residential
SubUse	Bungalow/ Dwelling / Non Apartment

FAR & Tenement Details (Table 4c-1)

Building	No. of Same Bldg	Total Built Up Area (Sq.mt.)	Proposed FAR Area (Sq.mt.) Resi.	Total FAR Area (Sq.mt.)	Total Consumed Additional FAR Area (Sq.mt.)	Tnmt (No.)
AA (AA)	1	82.66	82.66	82.66	82.66	01
Grand Total :	1	82.66	82.66	82.66	82.66	01

AREA STATEMENT	VERSION NO. : 1.0.62
JHUMRITILAIYA NAGAR PARISHAD	VERSION DATE: 16/10/2020
PROJECT DETAIL:	
Region: JHARKHAND URBAN LOCAL BODIES	Plot Use: Residential
District: KODERMA	Plot SubUse: Bungalow/ Dwelling / Non Apartment
Authority: JHUMRITILAIYA NAGAR PARISHAD	PlotNearbyReligiousStructure: NA
Inward No: JNP/IBP/0006/W07/2022	Plot/SubPlot No: 291
Application Type: General Proposal	North: Plot No. - LAND OF BINOD BARNWAL
Project Type: Building Permission	South: Plot No. - LAND OF SMT MUNNI DEVI
Nature of Development: New	East: Plot No. - LAND OF SUNITA DEVI
Location of Development Area: Old Area	West: Road Width - 3.65MTR WIDE ROAD
AREA DETAILS:	
AREA OF PLOT (Minimum)	(A) 68.10
NET AREA OF PLOT(Gross Plot Area - Deduction from Gross Plot area)	(A-Deductions) 68.10
Deduction for Balance Plot Area(from Gross Plot Area)	
Common Plot	10.86
Total	10.86
BALANCE AREA OF PLOT(Net Plot Area - Recreational/Amenity space)	(A-Deductions) 57.24
PLOT AREA FOR COVERAGE(Net Plot Area)	(A-Deductions) 68.10
Plot Area for FAR (Net Plot Area + RoadWidening Area)	(A-Deductions) 68.10
COVERAGE CHECK	
Permissible Coverage area ( 70.00 % )	47.67
Total Prop. Coverage Area ( 60.69 % )	41.33
Total Prop. Coverage Area ( 60.69 % )	41.33
Balance coverage area ( 9.31 % )	6.34
FAR CHECK	
Perm. FAR Area ( 1.50 )	102.15
Total Perm. FAR area	102.15
Residential FAR	82.65
Proposed FAR Area	82.65
Total Proposed FAR Area	82.65
Consumed FAR (Factor)	1.21
Balance FAR Area	19.50
BUILT UP AREA CHECK	
Total Proposed BuiltUp Area	82.66
ARCHITECT (Regd)	UPENDRA
ENGINEER (Regd)	
SUPERVISOR (Regd)	
OWNER (Regd)	SMT. RADHA DEVI
DEVELOPMENT AUTHORITY LOCAL BODY	

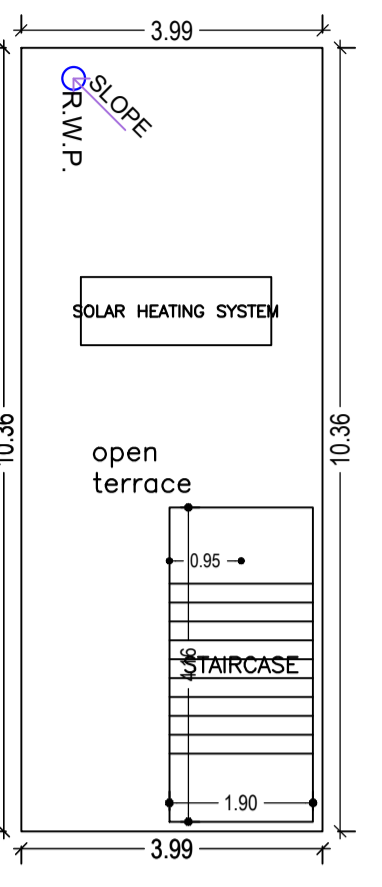
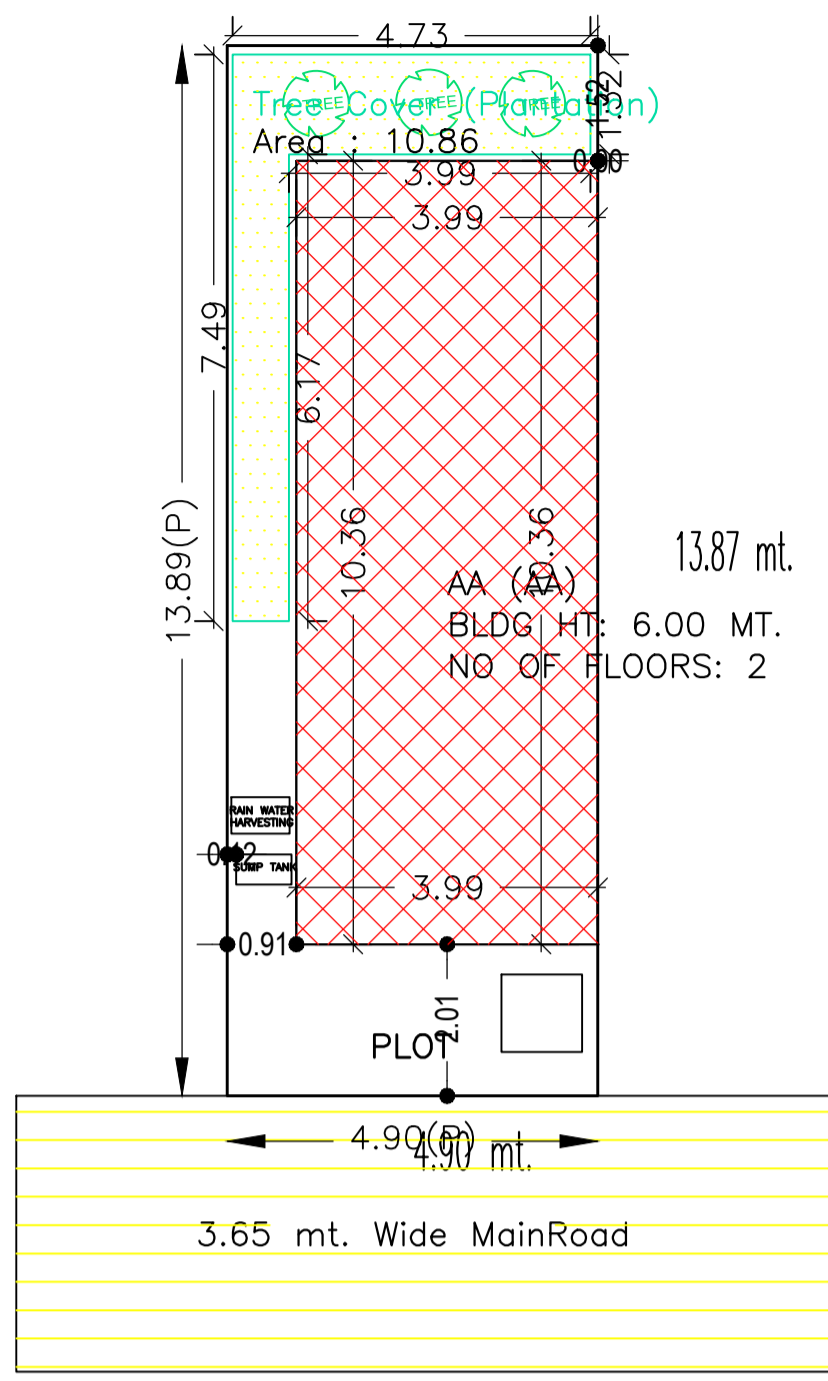

TERRACE FLOOR PLAN (SCALE 1:100)

site plan

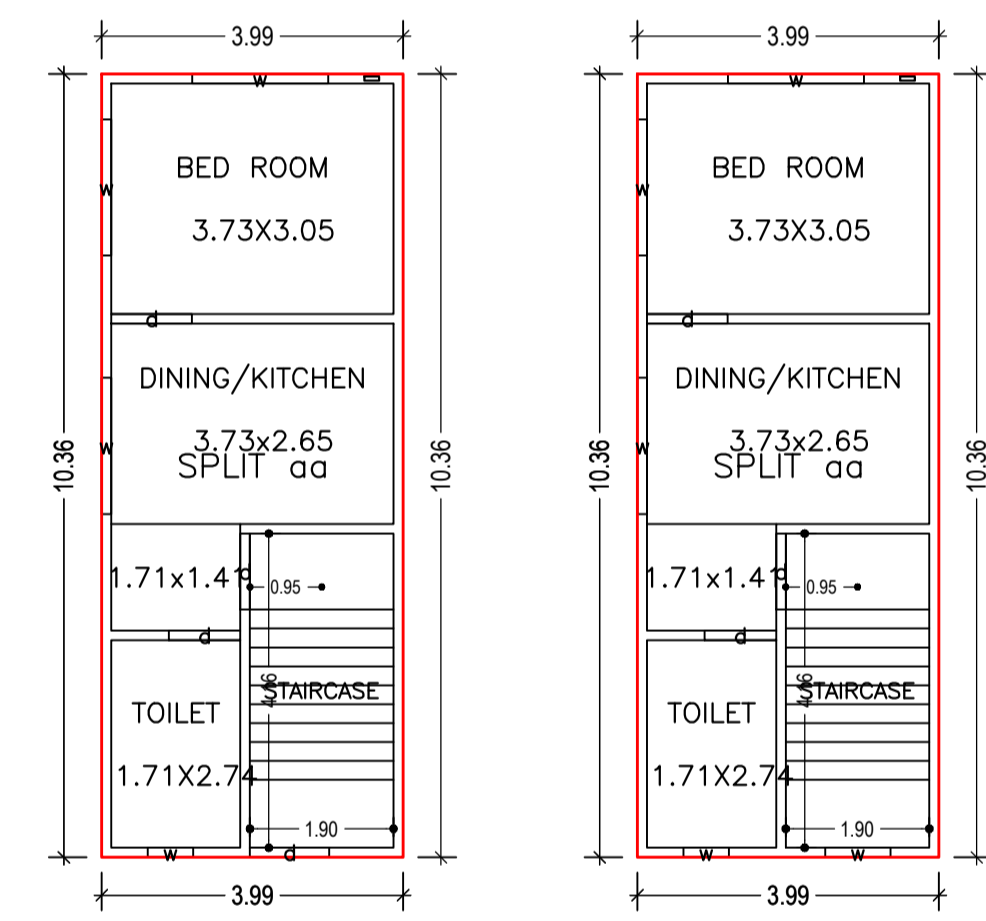

GROUND FLOOR PLAN (Proposed) (SCALE 1:100)

FIRST FLOOR PLAN (Proposed) (SCALE 1:100)

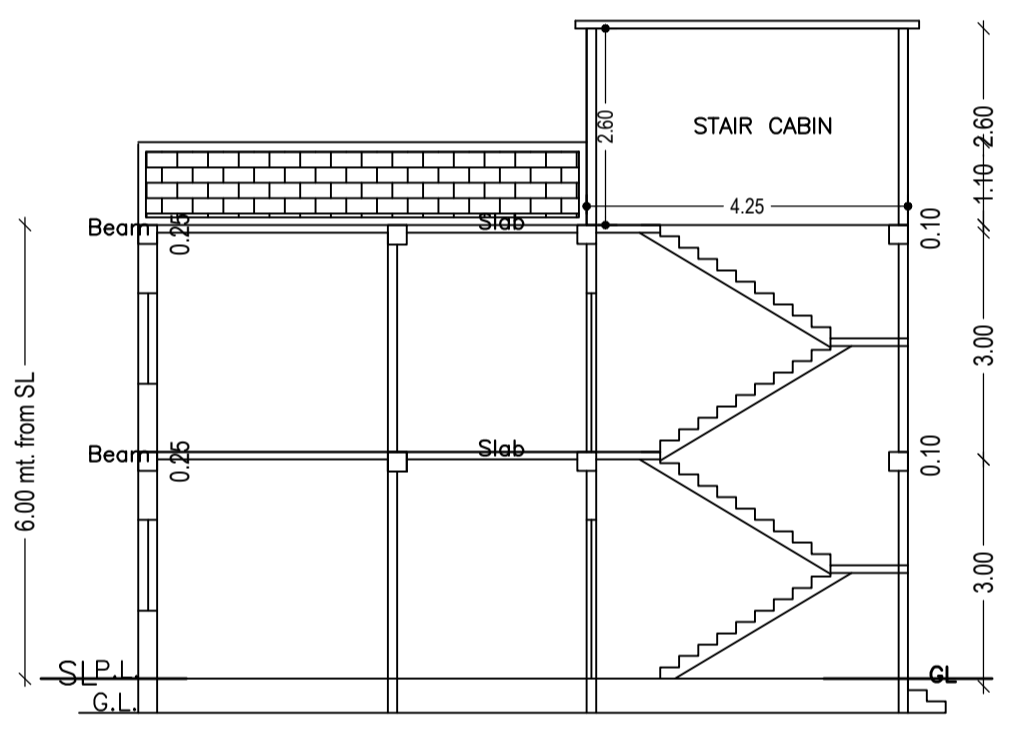

SECTION ON X-X

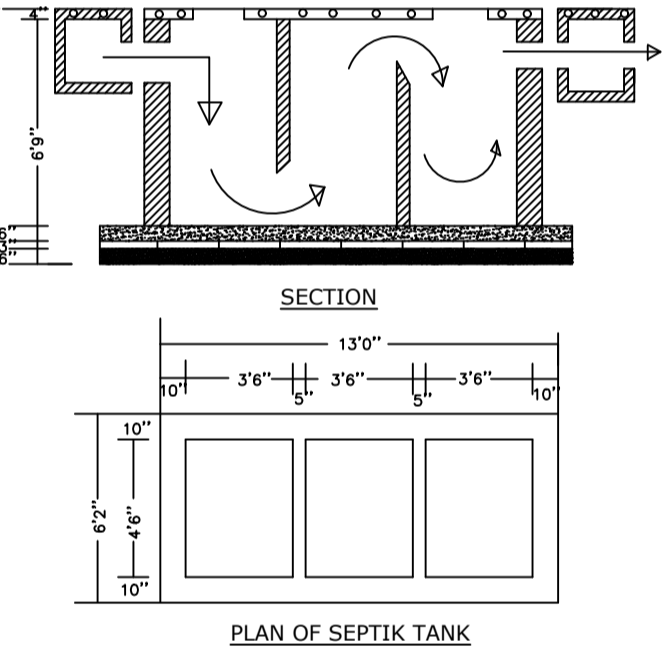
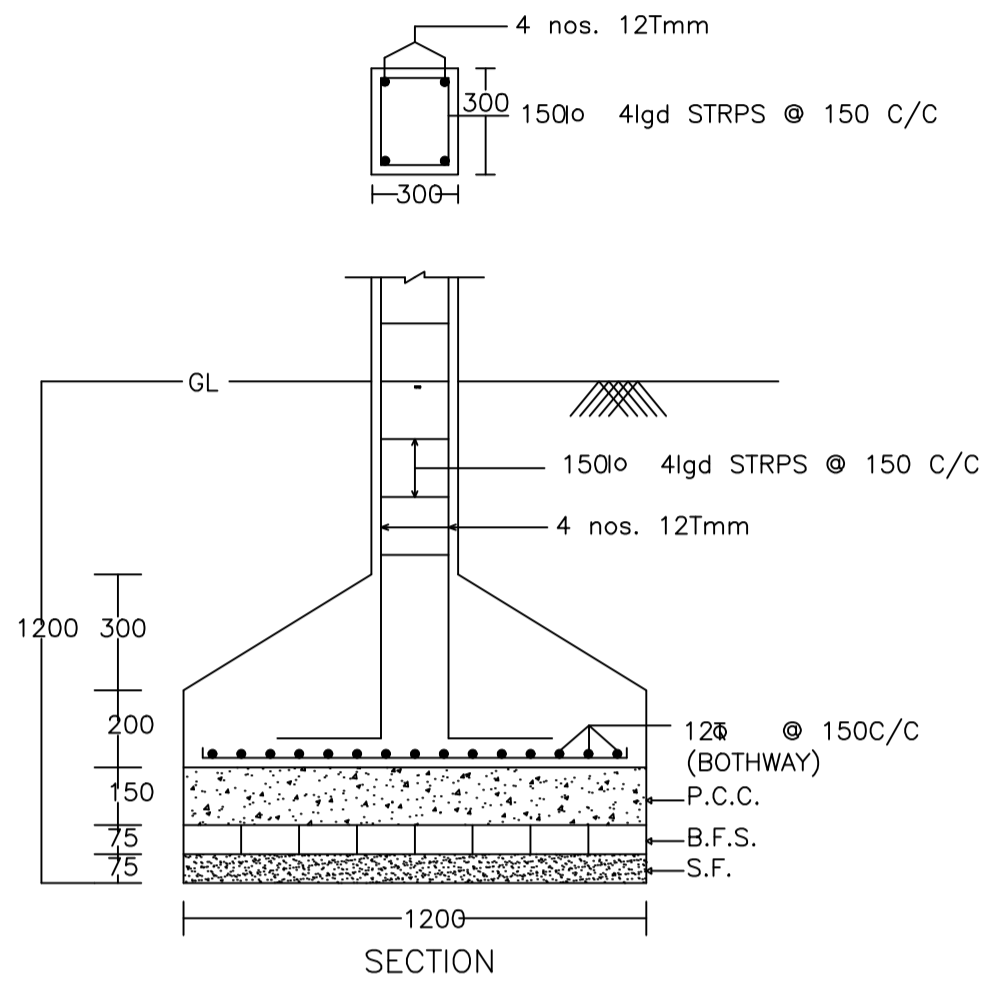
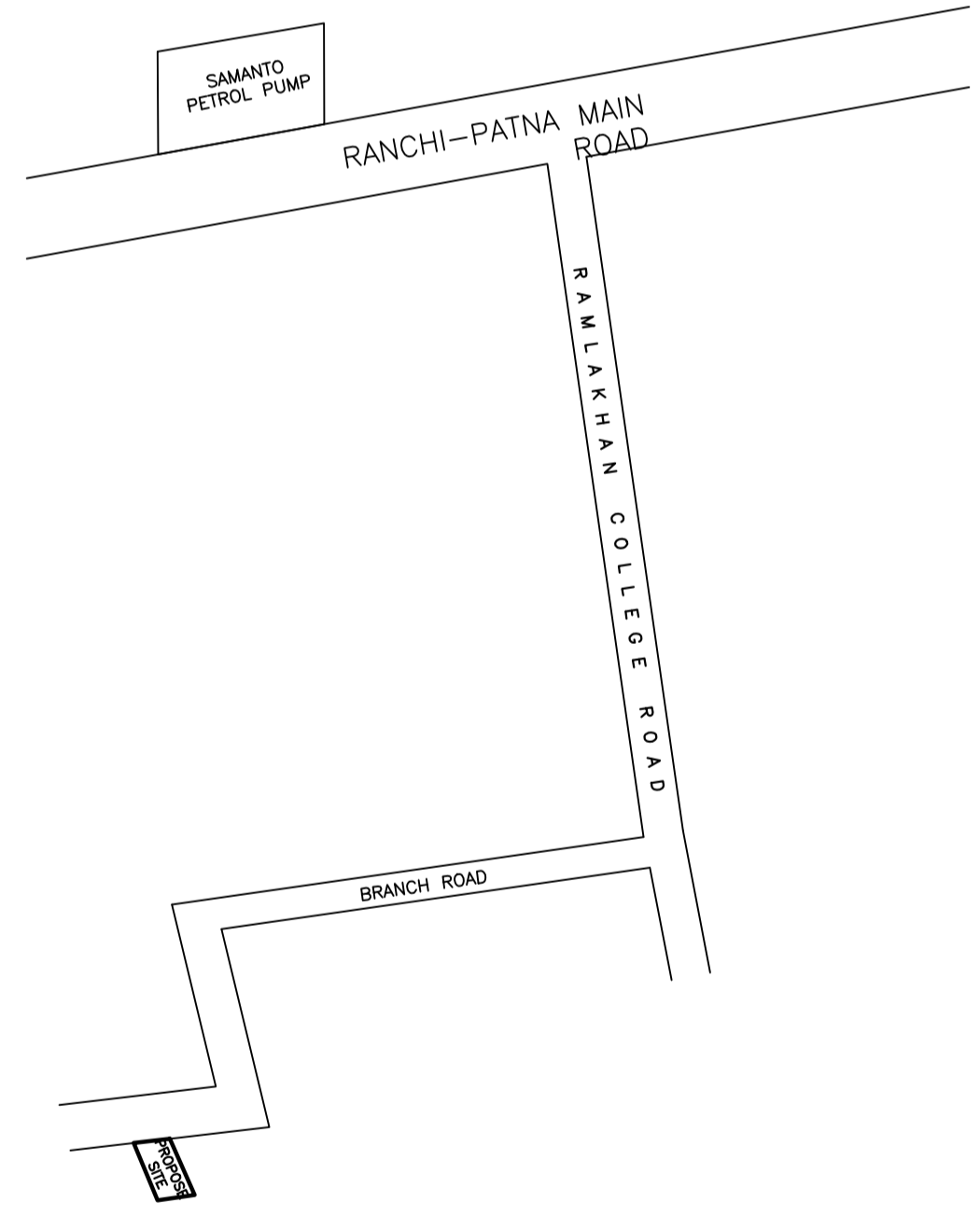

PLAN OF SEPTIK TANK

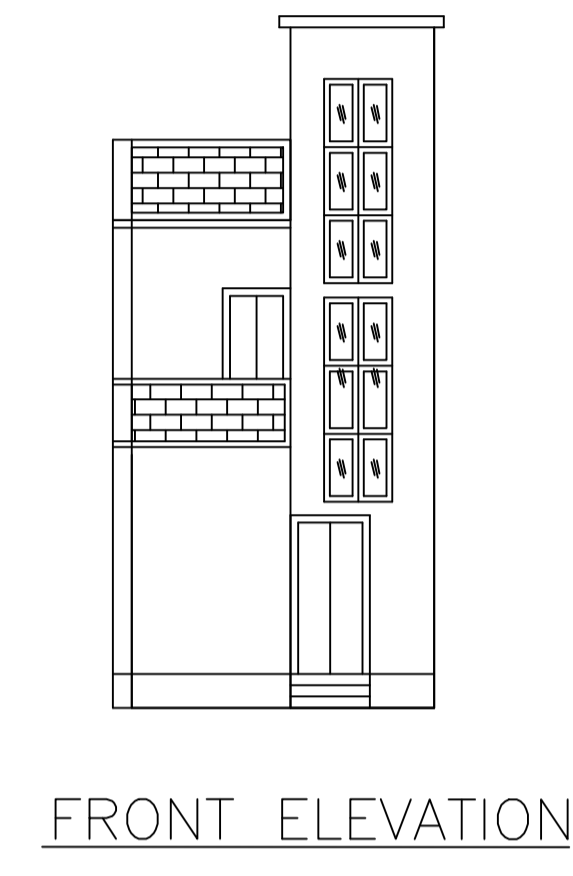

FRONT ELEVATION

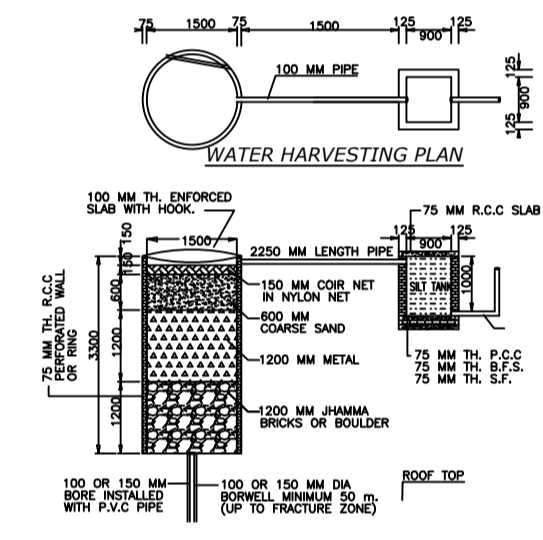

WATER HARVESTING PLAN

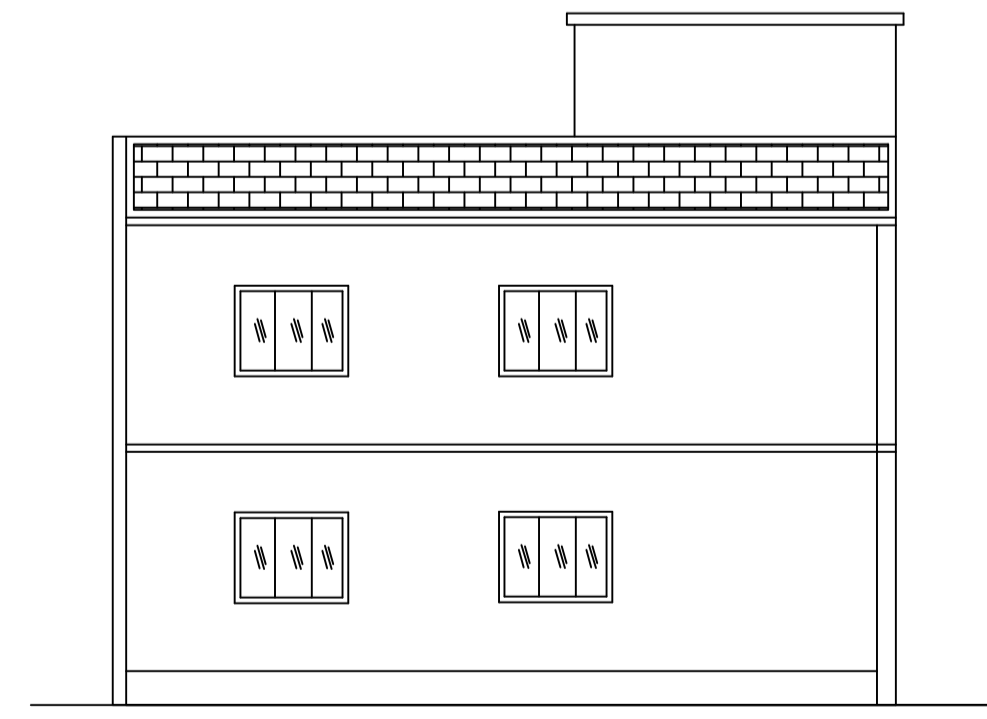

LEFT SIDE ELEVATION

COLOR INDEX	
PLOT BOUNDARY	Black
ABUTTING ROAD	Green
PROPOSED CONSTRUCTION	Red
COMMON PLOT	Yellow
ROAD WIDENING AREA	Orange
EXISTING (To be retained)	Blue
EXISTING (To be demolished)	Light Blue

Buildingwise Floor FAR Details

Floor Name	Building Name AA (AA)		Total	
	Proposed Built Up Area (Sq.mt.)	Proposed FAR Area (Sq.mt.)	Total Proposed Built Up Area (Sq.mt.)	Total FAR Area (Sq.mt.)
Ground Floor	41.33	41.33	41.33	41.33
First Floor	41.33	41.33	41.33	41.33
Terrace Floor	0.00	0.00	0.00	0.00
Total :	82.66	82.66	82.66	82.66

Building USE/SUBUSE Details

Building Name	Building Use	Building SubUse	Building Structure
AA (AA)	Residential	Bungalow/ Dwelling / Non Apartment	Non-Highrise

Building :AA (AA)

Floor Name	Total Built Up Area (Sq.mt.)	Proposed FAR Area (Sq.mt.) Resi.	Total FAR Area (Sq.mt.)	Total Consumed Additional FAR Area (Sq.mt.)	Tnmt (No.)
Ground Floor	41.33	41.33	41.33	41.33	01
First Floor	41.33	41.33	41.33	41.33	00
Terrace Floor	0.00	0.00	0.00	0.00	00
Total :	82.66	82.66	82.66	82.66	01
Total Number of Same Buildings	1				
Total :	82.66	82.66	82.66	82.66	01

SCHEDULE OF DOOR:

BUILDING NAME	NAME	LENGTH	HEIGHT	NOS
AA (AA)	d	0.94	2.10	02
AA (AA)	d	1.01	2.10	02
AA (AA)	d	1.07	2.10	02

SCHEDULE OF WINDOW/VENTILATION:

BUILDING NAME	NAME	LENGTH	HEIGHT	NOS
AA (AA)	w	0.60	1.20	02
AA (AA)	w	0.86	1.20	01
AA (AA)	w	1.80	1.20	06

UnitBUA Table for Building :AA (AA)

FLOOR	Name	UnitBUA Type	UnitBUA Area	Carpet Area	No. of Rooms	No. of Tenement
GROUND FLOOR PLAN	SPLIT aa	FLAT	82.65	82.63	3	1
FIRST FLOOR PLAN	SPLIT aa	FLAT	0.00	0.00	3	0
Total:	-	-	82.65	82.63	6	1

LTP NAME AND SIGNATURE	STRUCTURAL ENG'S NAME AND SIGNATURE	BUILDER NAME AND SIGNATURE	DIGITAL SIGNATURE
UPENDRA JNP/ENG/0012/2017			