

Proposal Basic Information	
Proposal File No.	JNP/BP/0062/W14/2022
Owner Name	SRI SANJAY SHARMA
Khata No	1213
Plot No	7164
Village Name	Tilaiya
Use	Residential
SubUse	Bungalow/ Dwelling / Non Apartment

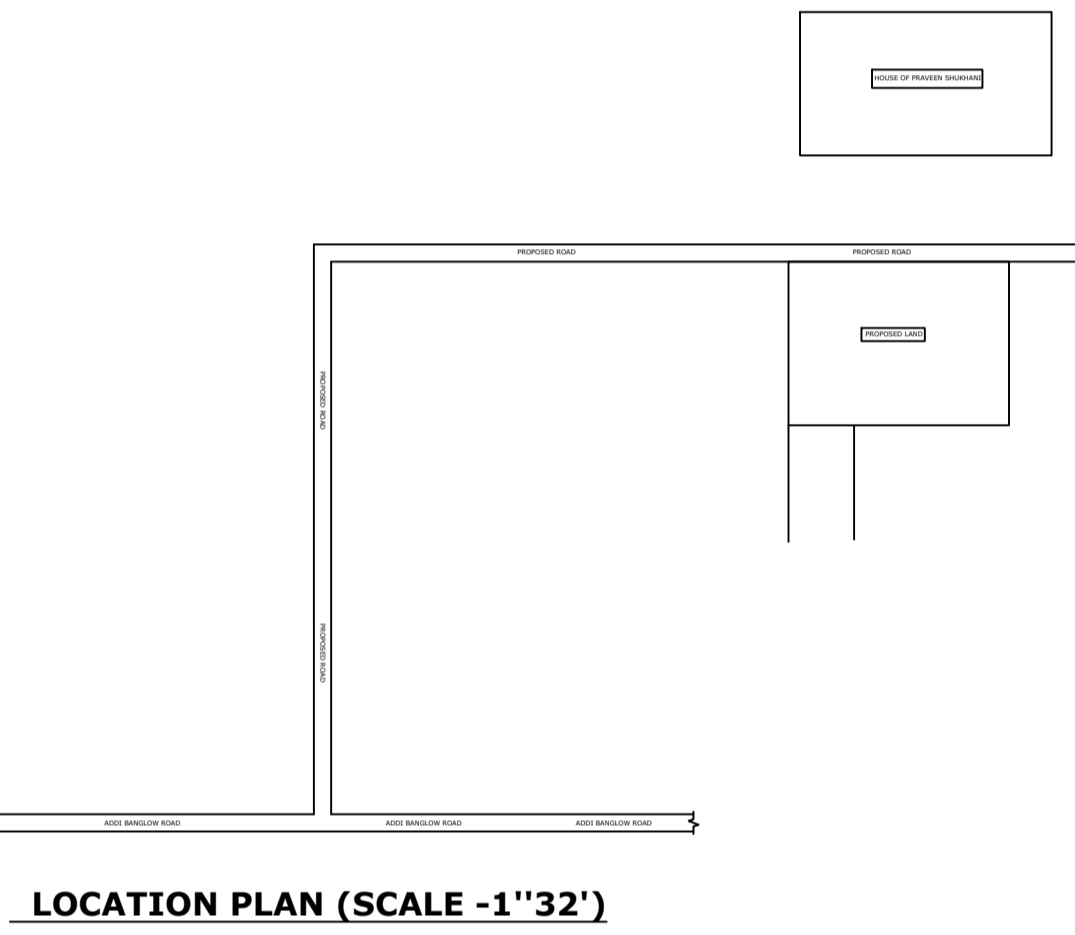
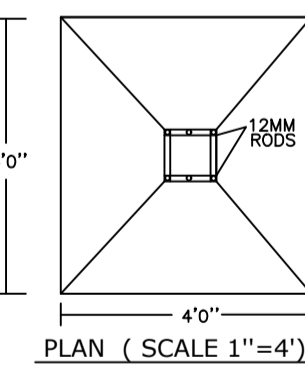
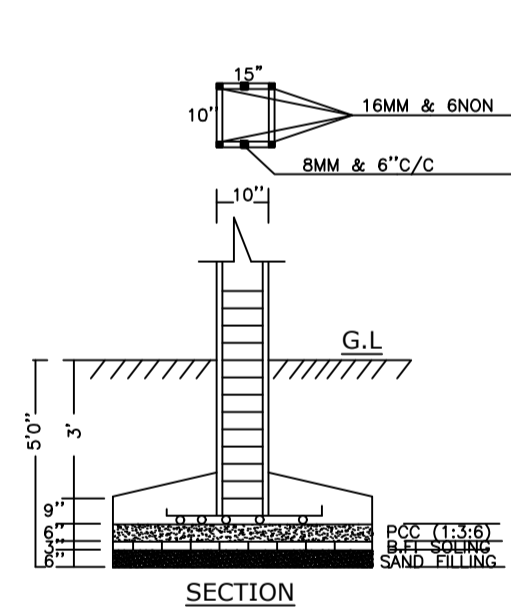
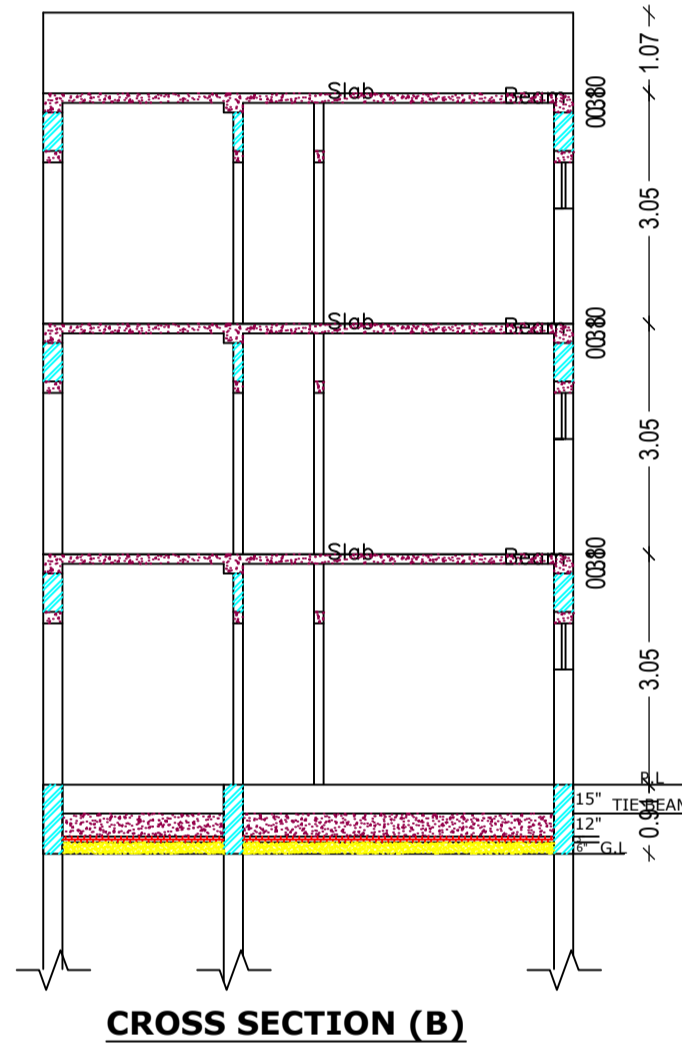
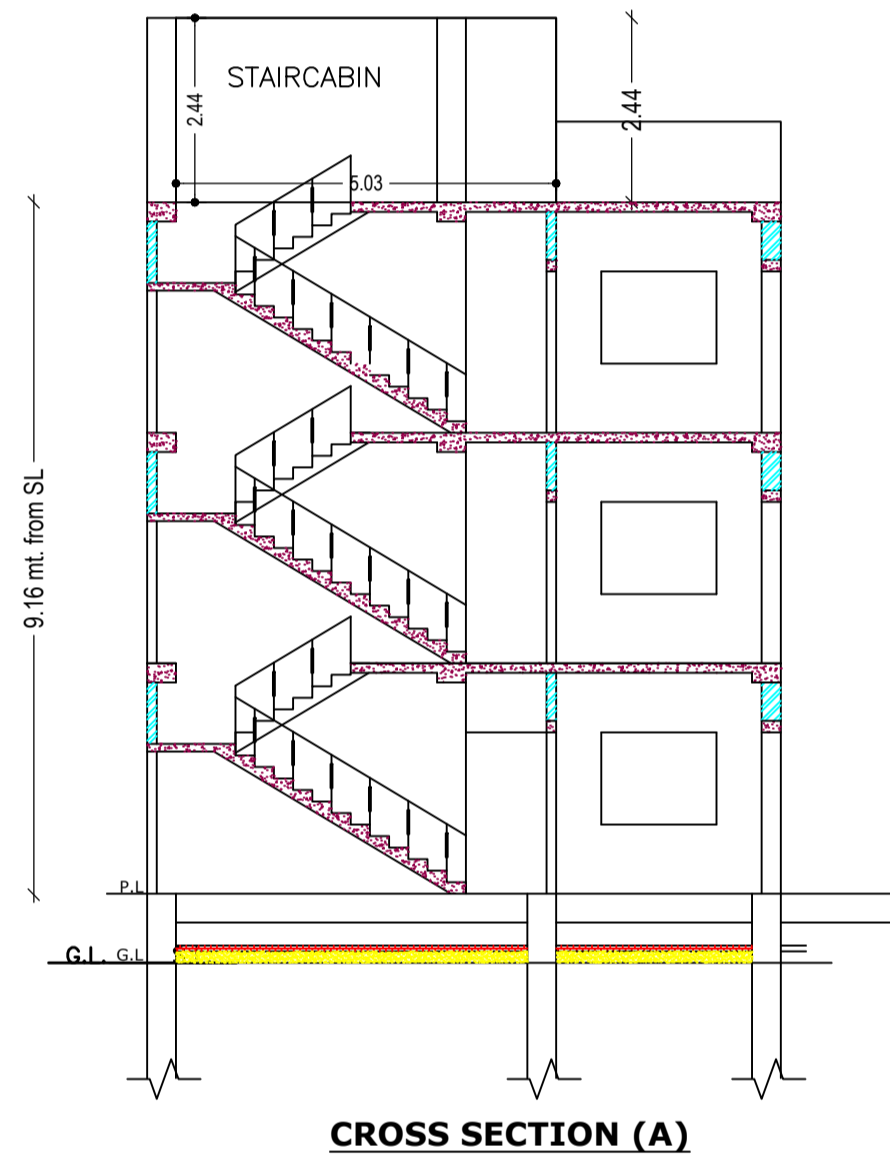
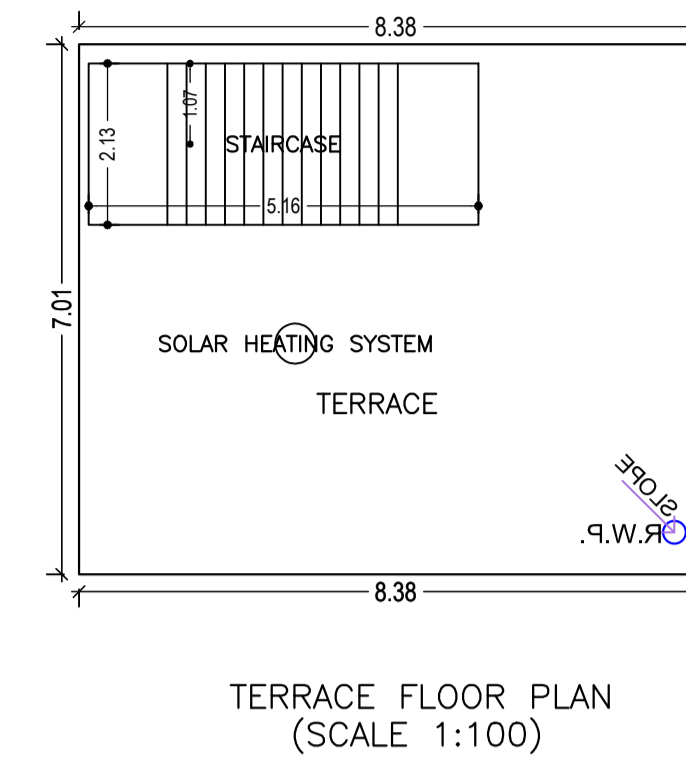
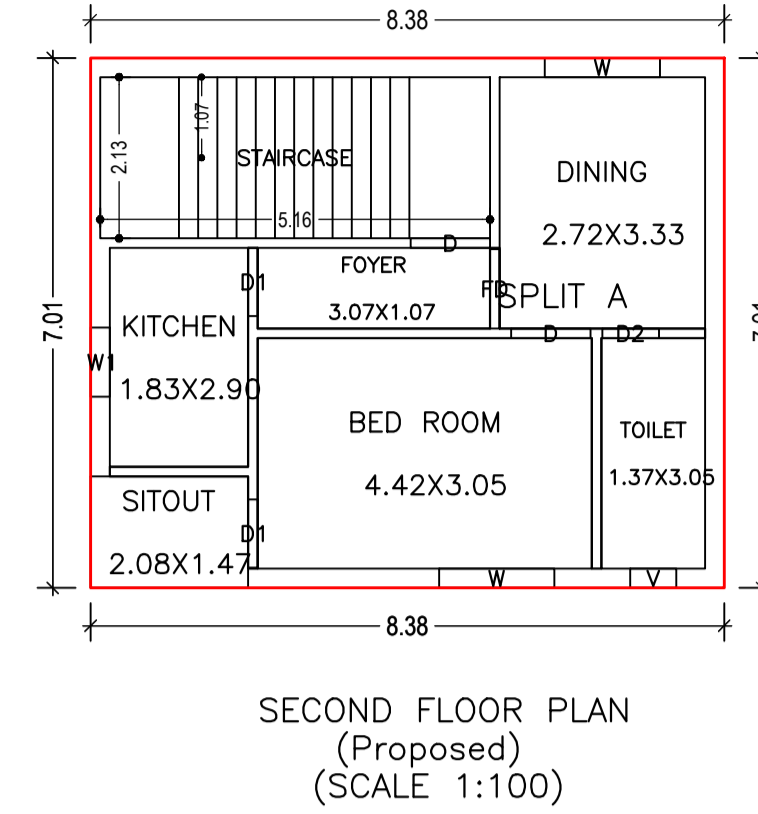
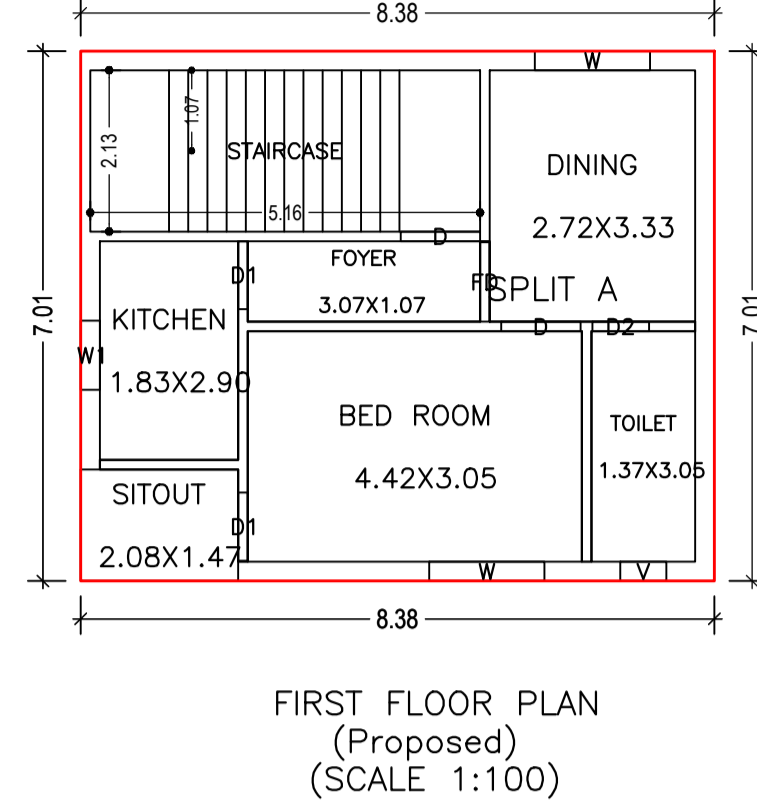
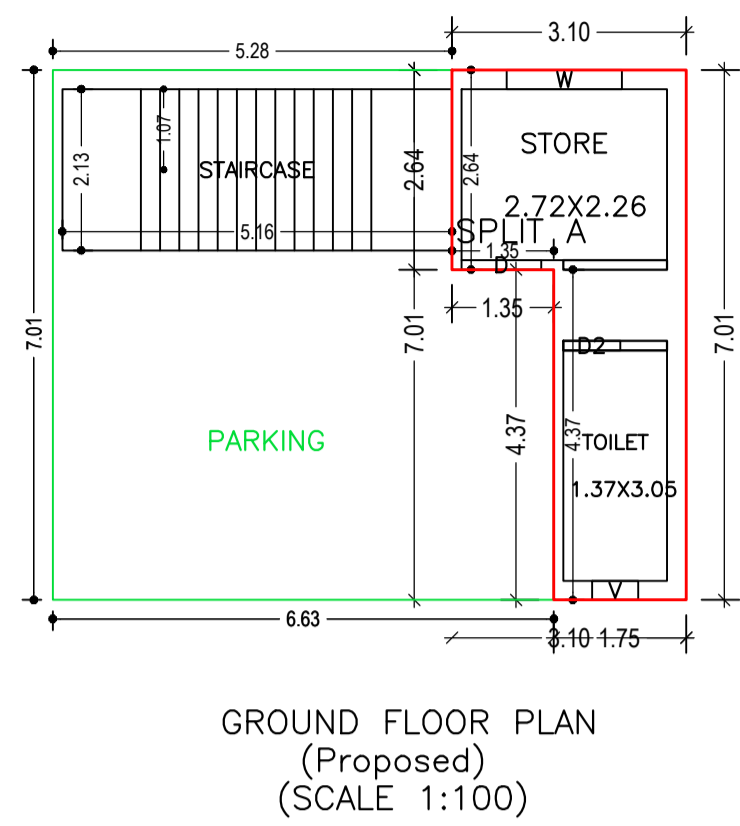
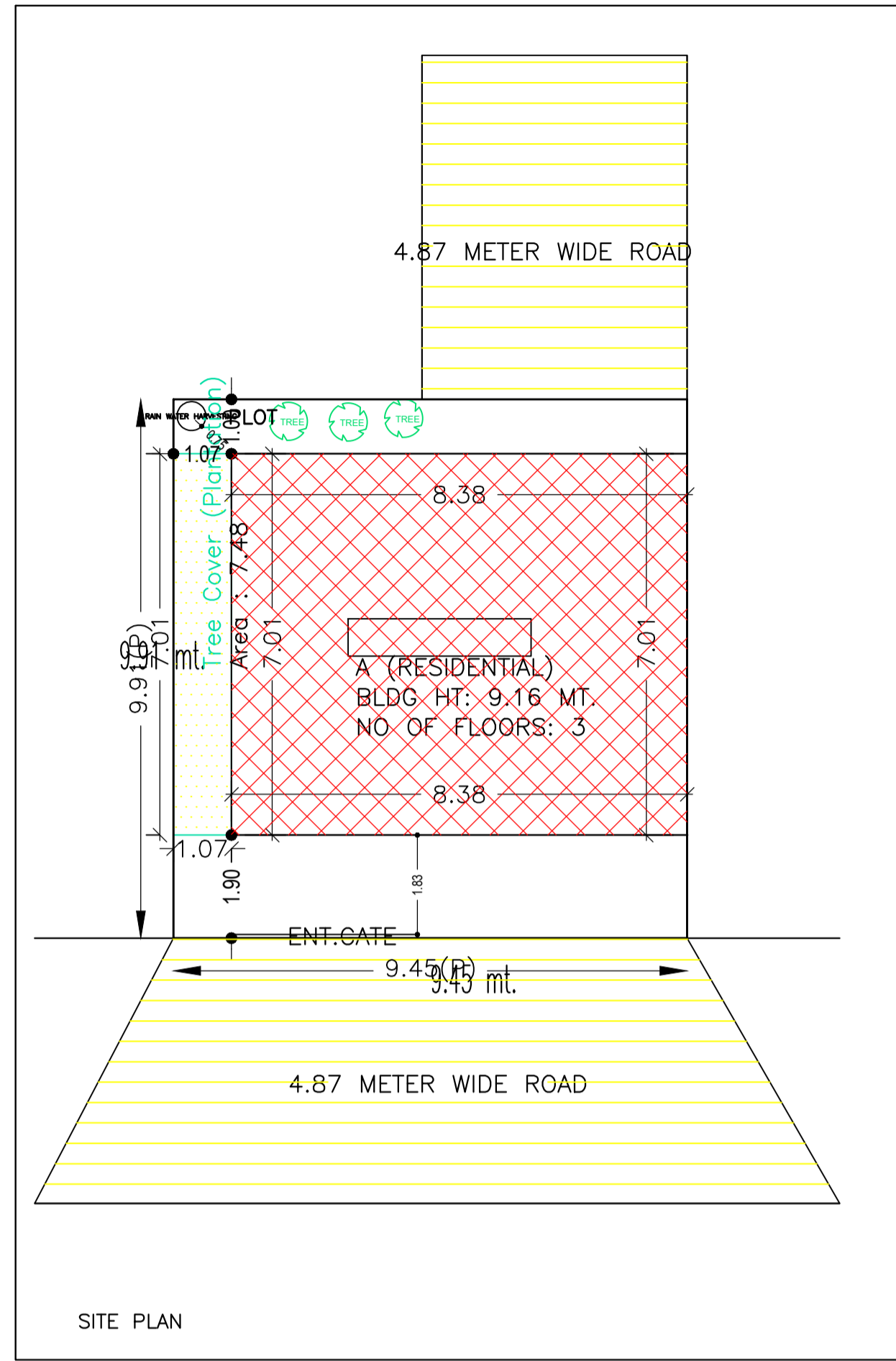

UnitBUA Table for Building :A (RESIDENTIAL)

FLOOR	Name	UnitBUA Type	UnitBUA Area	Carpet Area	No. of Rooms	No. of Tenement
GROUND FLOOR PLAN	SPLIT A	FLAT	92.73	88.29	2	1
FIRST FLOOR PLAN	SPLIT A	FLAT	0.00	0.00	6	0
SECOND FLOOR PLAN	SPLIT A	FLAT	0.00	0.00	6	0
Total:	-	-	92.73	88.29	14	1

Building :A (RESIDENTIAL)

Floor Name	Total Built Up Area (Sq.mt.)	Deductions (Area in Sq.mt.)	Proposed FAR Area (Sq.mt.)	Add Area In FAR (Sq.mt.)	Total FAR Area (Sq.mt.)	Total Consumed Additional FAR Area (Sq.mt.)	Tnmt (No.)
Ground Floor	58.76	31.92	15.84	11.00	26.84	26.84	01
First Floor	58.76	0.00	58.76	0.00	58.76	58.76	00
Second Floor	58.76	0.00	58.76	0.00	58.76	58.76	00
Terrace Floor	0.00	0.00	0.00	0.00	0.00	0.00	00
Total:	176.28	31.92	133.36	11.00	144.36	144.36	01

AREA STATEMENT		VERSION NO. : 1.0.64
JHUMRITILAIYA NAGAR PARISHAD		VERSION DATE: 16/10/2020
PROJECT DETAIL:		
Region: JHARKHAND URBAN LOCAL BODIES	Plot Use: Residential	
District: KODERMA	Plot SubUse: Bungalow/ Dwelling / Non Apartment	
Authority: JHUMRITILAIYA NAGAR PARISHAD	PlotNearbyReligiousStructure: NA	
Inward_No: JNP/BP/0062/W14/2022	PlotSubPlot No: 7164	
Application Type: General Proposal	North: Road Width - 4.87	
Project Type: Building Permission	South: Road Width - 4.87 AND NAWAL KISHOR DARUKA	
Nature of Development: New	East: Plot No. - NIJ VENDOR	
Location of Development Area: Old Area	West: Plot No. - NIJ VENDOR	
AREA DETAILS:		
AREA OF PLOT (Minimum)	(A)	SQ.MT. 93.60
NET AREA OF PLOT(Gross Plot Area - Deduction from Gross Plot area)	(A-Deductions)	93.60
Deduction for Balance Plot Area(from Gross Plot Area)		
Common Plot		7.48
Total		7.48
BALANCE AREA OF PLOT(Net Plot Area - Recreational/Amenity space)	(A-Deductions)	86.12
PLOT AREA FOR COVERAGE(Net Plot Area)	(A-Deductions)	93.60
Plot Area for FAR (Net Plot Area + Road/Widening Area)	(A-Deductions)	93.60
COVERAGE CHECK		
Permissible Coverage area (70.00 %)		65.52
Proposed Coverage Area (62.78 %)		58.76
Total Prop. Coverage Area (62.78 %)		58.76
Balance coverage area (7.22 %)		6.76
FAR CHECK		
Perm. FAR Area (1.80)		168.48
Incentive FAR Area (1.800)		168.48
Perm. FAR Area (3.600)		336.96
Total Perm. FAR area		336.96
Residential FAR		133.36
Proposed FAR Area		144.37
Total Proposed FAR Area		144.37
Consumed FAR (Factor)		1.54
Balance FAR Area		192.59
BUILT UP AREA CHECK		
Total Proposed BuiltUp Area		176.28
ARCHITECT (Regd)		KIRAN KUMARI
ENGINEER (Regd)		
SUPERVISOR (Regd)		
OWNER (Regd)		SRI SANJAY SHARMA
DEVELOPMENT AUTHORITY		LOCAL BODY

Buildingwise Floor FAR Details

Floor Name	Building Name A (RESIDENTIAL)		Total	
	Proposed Built Up Area (Sq.mt.)	Proposed FAR Area (Sq.mt.)	Total Proposed Built Up Area (Sq.mt.)	Total FAR Area (Sq.mt.)
Ground Floor	58.76	26.84	58.76	26.84
First Floor	58.76	58.76	58.76	58.76
Second Floor	58.76	58.76	58.76	58.76
Terrace Floor	0.00	0.00	0.00	0.00
Total:	176.28	144.36	176.28	144.36

Building USE/SUBUSE Details

Building Name	Building Use	Building SubUse	Building Structure
A (RESIDENTIAL)	Residential	Bungalow/ Dwelling / Non Apartment	Non-Highrise

FAR & Tenement Details (Table 4c-1)

Building	No. of Same Bldg	Total Built Up Area (Sq.mt.)	Deductions (Area in Sq.mt.)	Proposed FAR Area (Sq.mt.)	Add Area In FAR (Sq.mt.)	Total FAR Area (Sq.mt.)	Total Consumed Additional FAR Area (Sq.mt.)	Tnmt (No.)
A (RESIDENTIAL)	1	176.28	31.92	133.36	11.00	144.36	144.36	01
Grand Total:	1	176.28	31.92	133.36	11.00	144.36	144.36	01

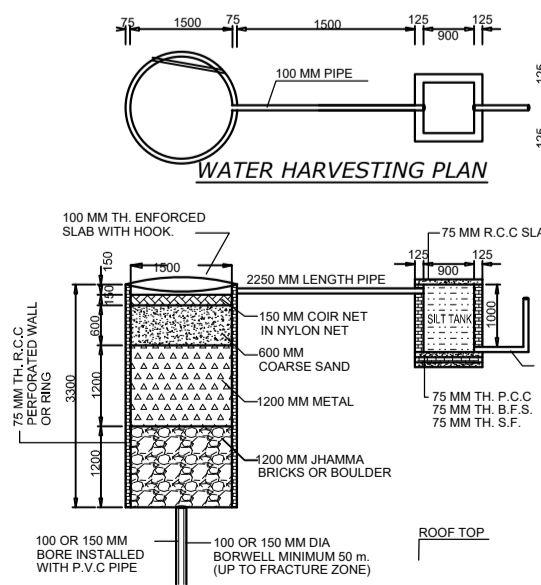
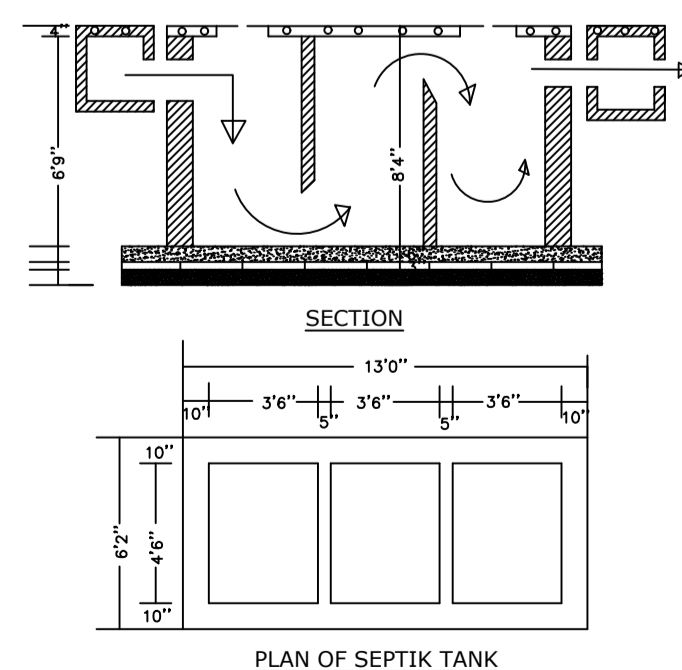
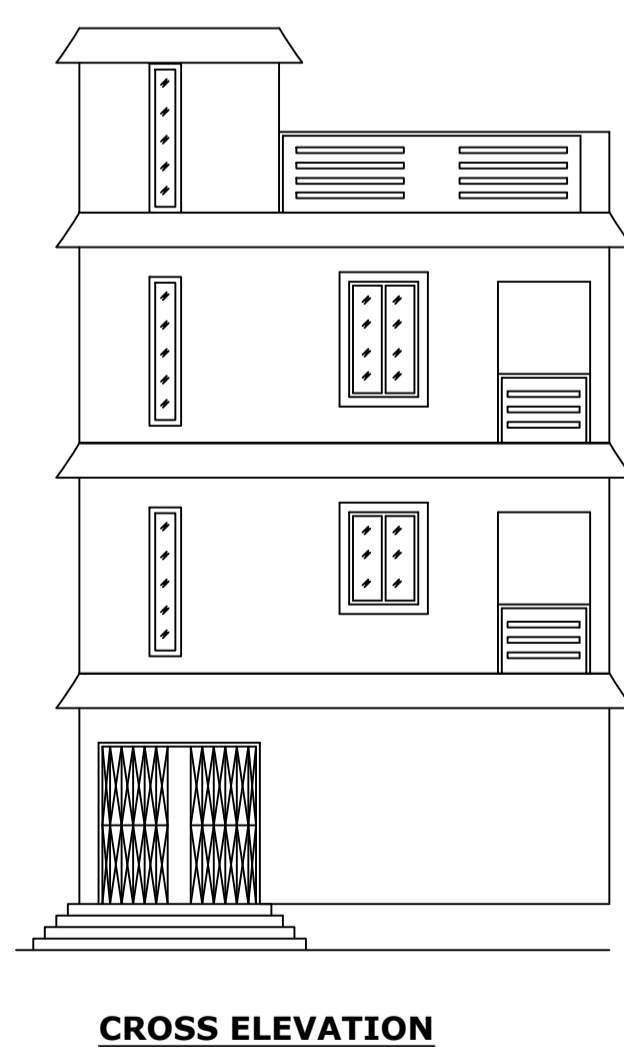
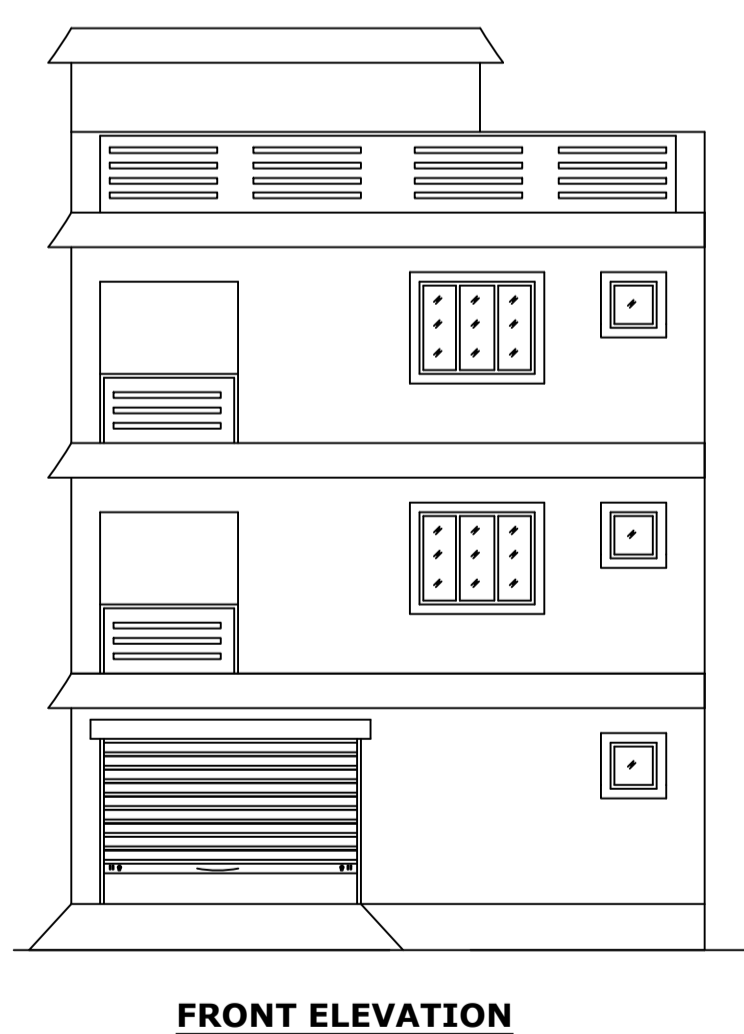

COLOR INDEX

PLOT BOUNDARY	Black
ABUTTING ROAD	Red
PROPOSED CONSTRUCTION	Green
COMMON PLOT	Blue
ROAD WIDENING AREA	Yellow
EXISTING (To be retained)	Light Blue
EXISTING (To be demolished)	Light Yellow

SCHEDULE OF DOOR:

BUILDING NAME	NAME	LENGTH	HEIGHT	NOS
A (RESIDENTIAL)	D2	0.75	2.10	03
A (RESIDENTIAL)	D1	0.90	2.10	04
A (RESIDENTIAL)	D	1.05	2.10	05
A (RESIDENTIAL)	FD	1.05	2.10	02

SCHEDULE OF WINDOW/VENTILATION:

BUILDING NAME	NAME	LENGTH	HEIGHT	NOS
A (RESIDENTIAL)	V	0.61	1.20	03
A (RESIDENTIAL)	W1	0.91	1.20	02
A (RESIDENTIAL)	W	1.52	1.20	05

LTP NAME AND SIGNATURE	STRUCTURAL ENG'S NAME AND SIGNATURE	BUILDER NAME AND SIGNATURE	DIGITAL SIGNATURE
KIRAN KUMARI JNP/ENG/001/2019			