

Proposal Basic Information

Proposal File No.	JNP/IBP/0043/W14/2022
Owner Name	SMT BINA DEVI
Khata No	381
Plot No	7162
Village Name	Tilaiya
Use	Residential
SubUse	Bungalow/ Dwelling / Non Apartment

FAR & Tenement Details (Table 4c-1)

Building	No. of Same Bldg	Total Built Up Area (Sq.mt.)	Proposed FAR Area (Sq.mt.) Resi.	Total FAR Area (Sq.mt.)	Total Consumed Additional FAR Area (Sq.mt.)	Tnmt (No.)
AA (BINA DEVI)	1	89.07	89.07	89.07	89.07	01
<b>Grand Total :</b>	<b>1</b>	<b>89.07</b>	<b>89.07</b>	<b>89.07</b>	<b>89.07</b>	<b>01</b>

AREA STATEMENT	VERSION NO. : 1.0.62
JHUMRITILAIYA NAGAR PARISHAD	VERSION DATE: 16/10/2020
PROJECT DETAIL:	
Region: JHARKHAND URBAN LOCAL BODIES	Plot Use: Residential
District: KODERMA	Plot SubUse: Bungalow/ Dwelling / Non Apartment
Authority: JHUMRITILAIYA NAGAR PARISHAD	PlotNearby/ReligiousStructure: NA
Inward No: JNP/IBP/0043/W14/2022	Plot/SubPlot No: 7162
Application Type: General Proposal	North: Plot No. - NIZ VENDOR
Project Type: Building Permission	South: Plot No. - PLOT OF VENDOR
Nature of Development: New	East: Plot No. - LAND OF NAWAL KISHOR DARUKA AND OTHERS (P.N-7160 (P)& 7162 (P))
Location of Development Area: Old Area	West: Road Width - 4.88M WIDE ROAD
AREA DETAILS:	
AREA OF PLOT (Minimum)	(A) 53.48
NET AREA OF PLOT(Gross Plot Area - Deduction from Gross Plot area)	(A-Deductions) 53.48
Deduction for Balance Plot Area(from Gross Plot Area)	
Common Plot Total	7.01
BALANCE AREA OF PLOT(Net Plot Area - Recreational/Amenity space)	(A-Deductions) 46.47
PLOT AREA FOR COVERAGE(Net Plot Area)	(A-Deductions) 53.48
Plot Area for FAR (Net Plot Area + RoadWidening Area)	(A-Deductions) 53.48
COVERAGE CHECK	
Permissible Coverage area ( 70.00 % )	37.44
Proposed Coverage Area ( 55.52 % )	29.69
Total Prop. Coverage Area ( 55.52 % )	29.69
Balance coverage area ( 14.49 % )	7.75
FAR CHECK	
Perm. FAR Area ( 1.80 )	96.26
Total Perm. FAR area	96.26
Residential FAR	89.08
Proposed FAR Area	89.08
Total Proposed FAR Area	89.08
Consumed FAR (Factor)	1.67
Balance FAR Area	7.18
BUILT UP AREA CHECK	
Total Proposed BuiltUp Area	89.07
ARCHITECT (Regd)	MD SHOAB ALAM
ENGINEER (Regd)	
SUPERVISOR (Regd)	
OWNER (Regd)	SMT BINA DEVI
DEVELOPMENT AUTHORITY LOCAL BODY	

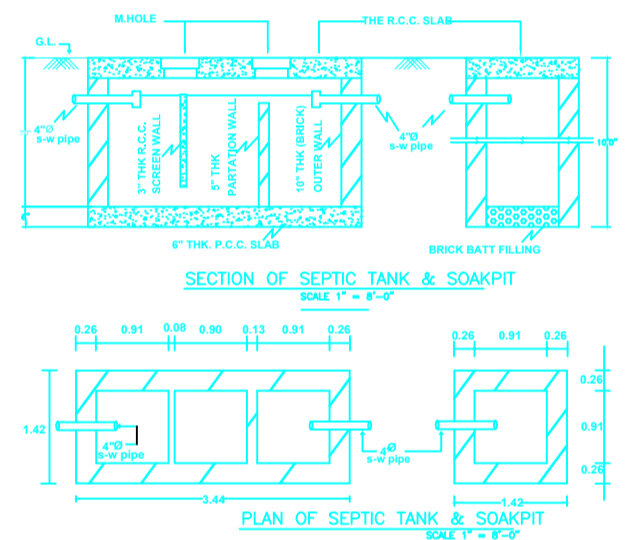
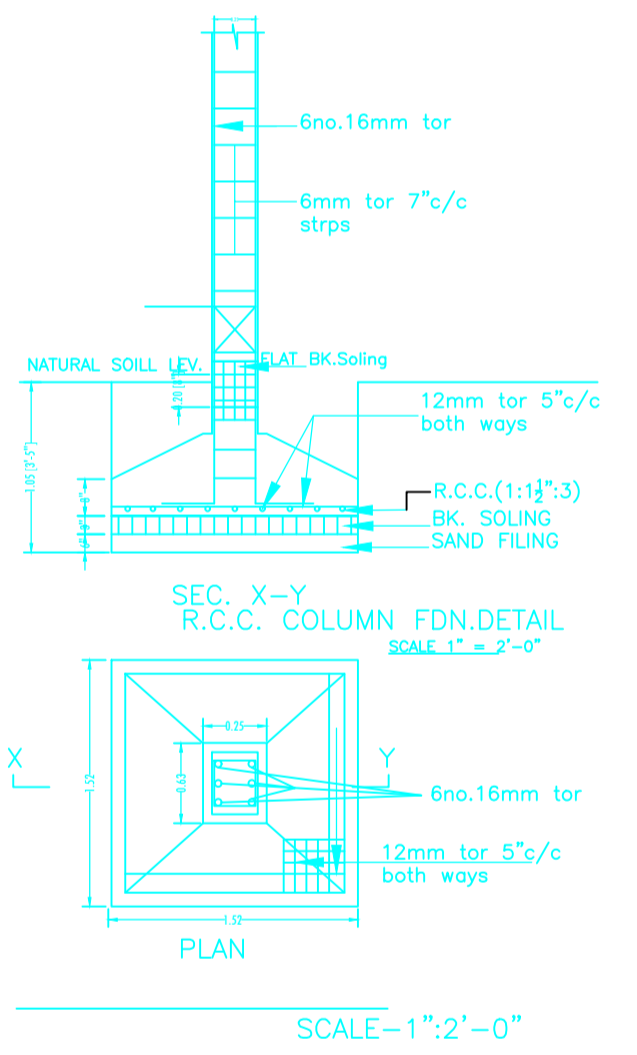
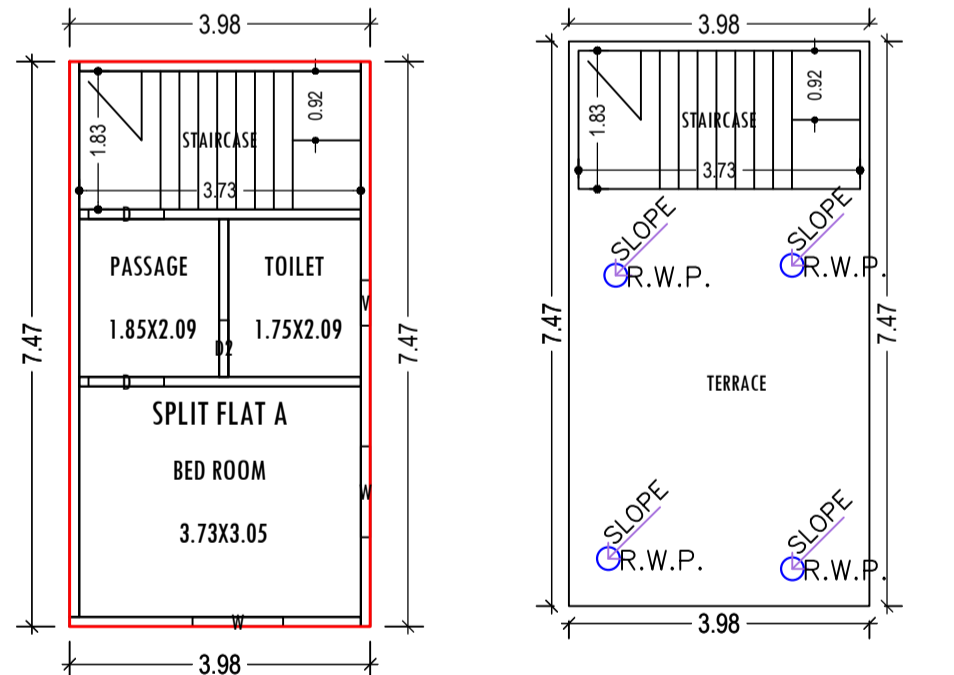
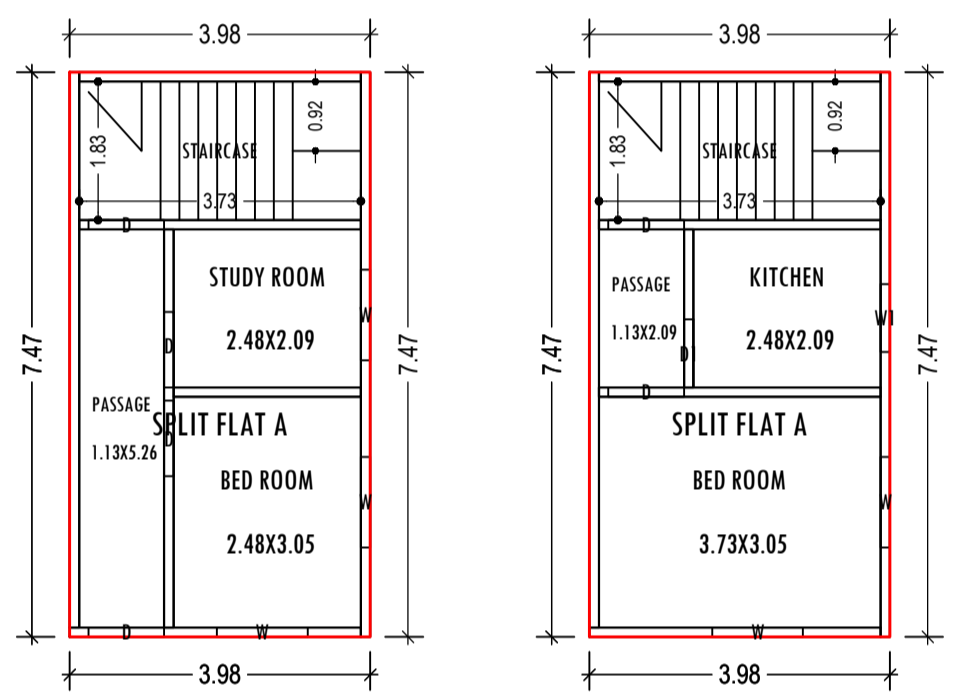
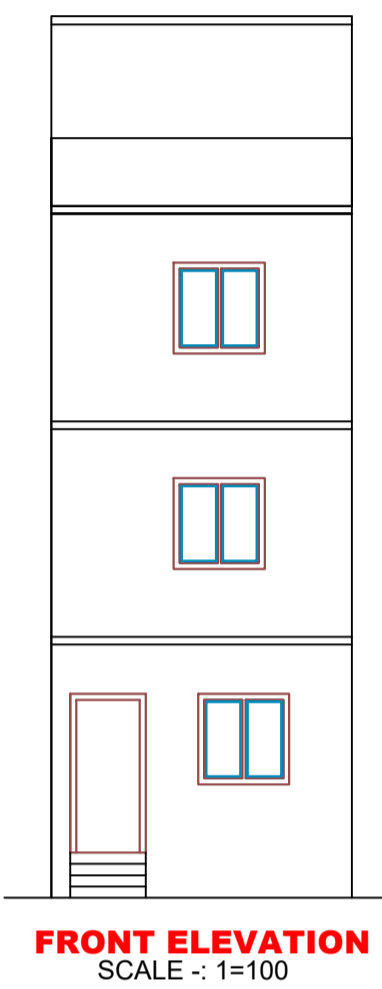
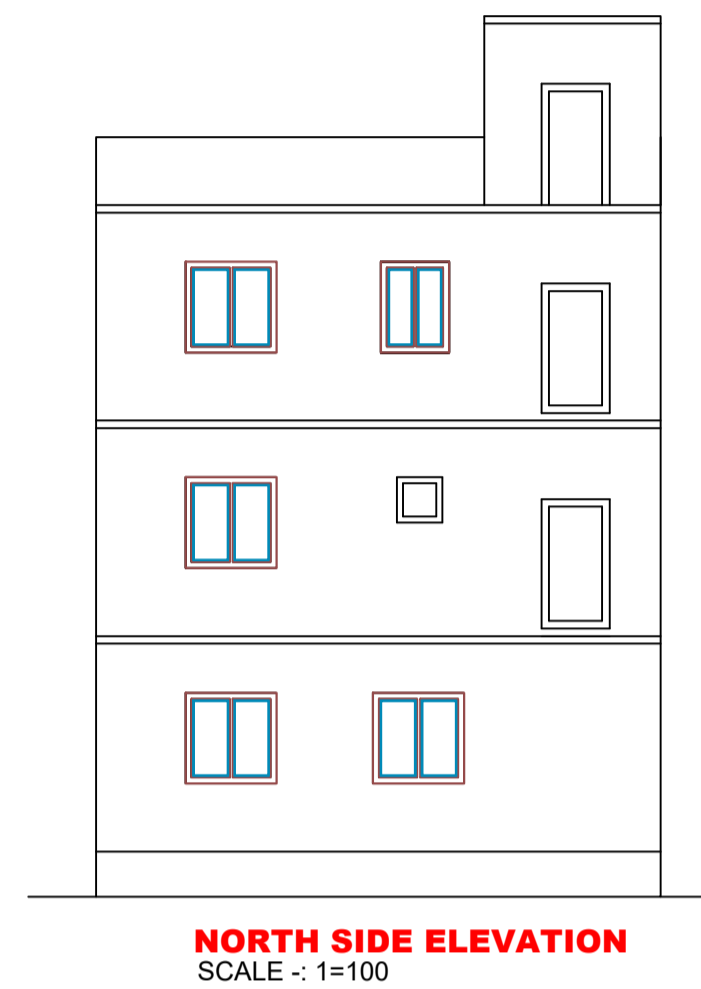
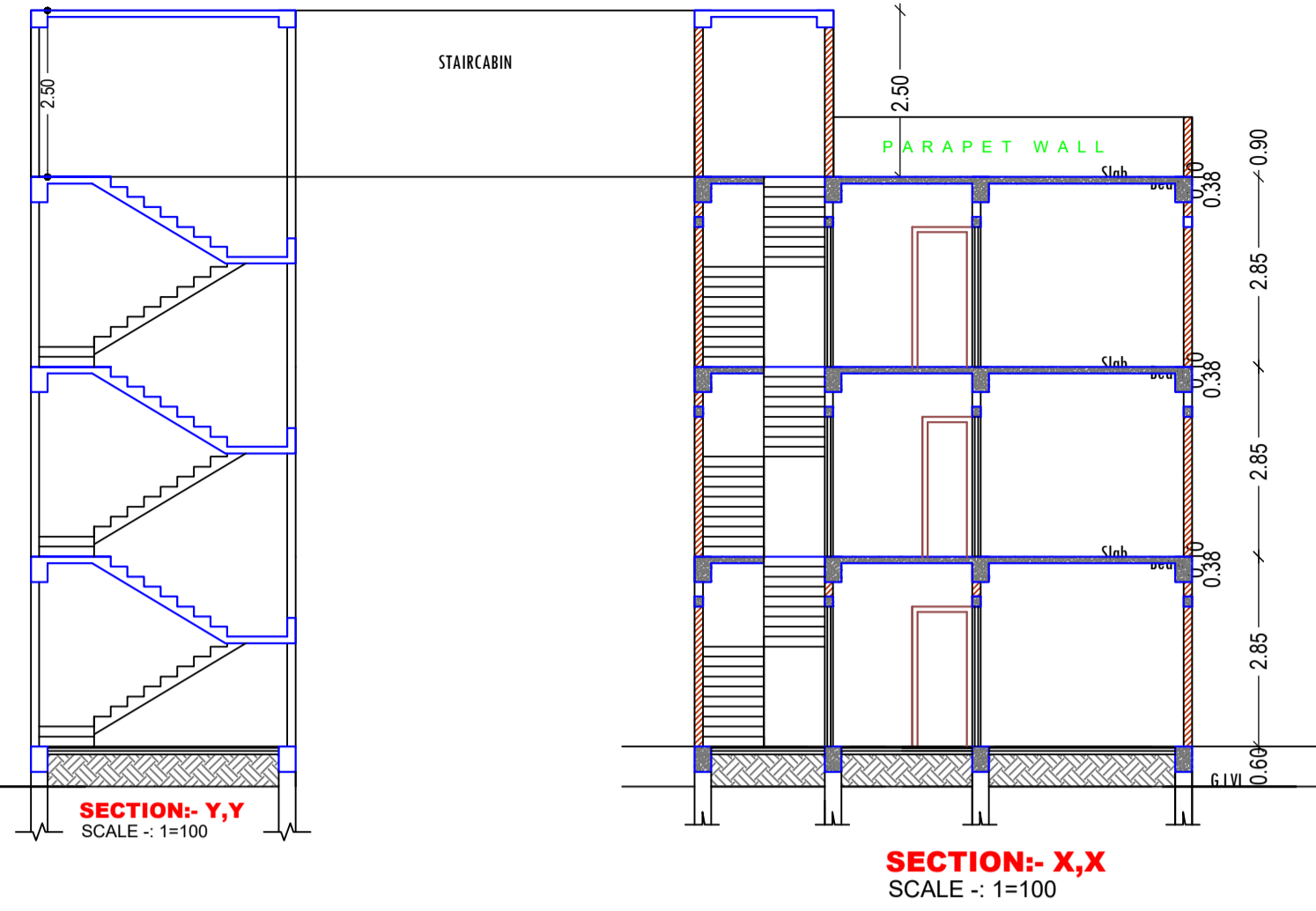
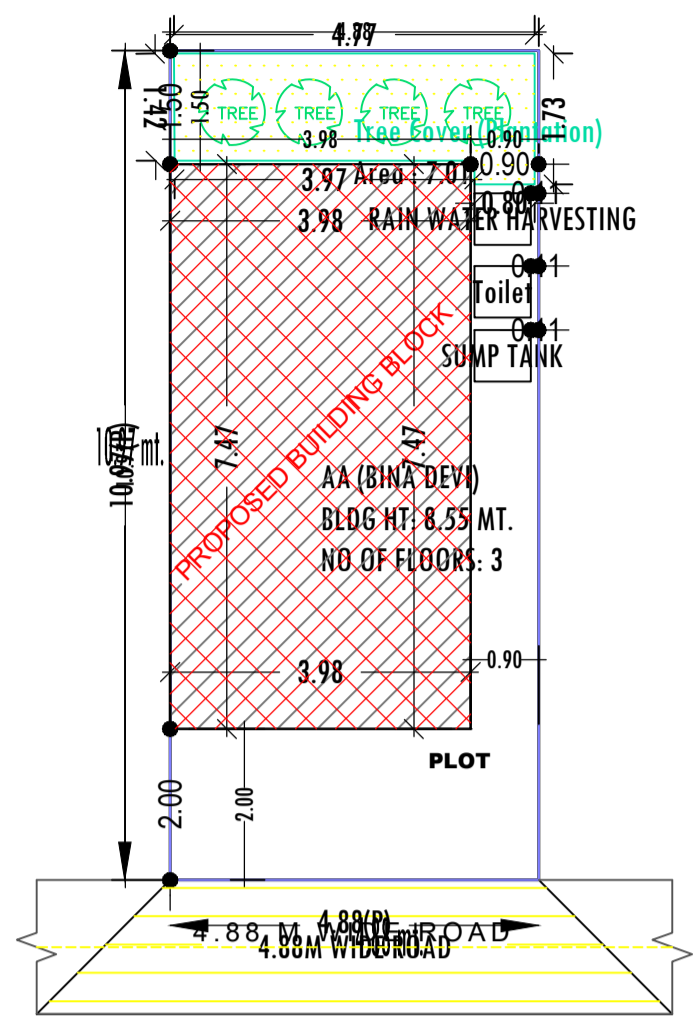

COLOR INDEX

PLOT BOUNDARY	Black
ABUTTING ROAD	Green
PROPOSED CONSTRUCTION	Red
COMMON PLOT	Yellow
ROAD WIDENING AREA	Orange
EXISTING (To be retained)	Blue
EXISTING (To be demolished)	Light Blue

Building -AA (BINA DEVI)

Floor Name	Total Built Up Area (Sq.mt.)	Proposed FAR Area (Sq.mt.) Resi.	Total FAR Area (Sq.mt.)	Total Consumed Additional FAR Area (Sq.mt.)	Tnmt (No.)
Ground Floor	29.69	29.69	29.69	29.69	01
First Floor	29.69	29.69	29.69	29.69	00
Second Floor	29.69	29.69	29.69	29.69	00
Terrace Floor	0.00	0.00	0.00	0.00	00
<b>Total :</b>	<b>89.07</b>	<b>89.07</b>	<b>89.07</b>	<b>89.07</b>	<b>01</b>
Total Number of Same Buildings	1				
<b>Total :</b>	<b>89.07</b>	<b>89.07</b>	<b>89.07</b>	<b>89.07</b>	<b>01</b>

SCHEDULE OF DOOR:

BUILDING NAME	NAME	LENGTH	HEIGHT	NOS
AA (BINA DEVI)	D2	0.75	2.10	01
AA (BINA DEVI)	D1	0.90	2.10	01
AA (BINA DEVI)	D	1.00	2.10	01
AA (BINA DEVI)	D	1.00	2.13	07

SCHEDULE OF WINDOW/VENTILATION:

BUILDING NAME	NAME	LENGTH	HEIGHT	NOS
AA (BINA DEVI)	V	0.60	0.60	01
AA (BINA DEVI)	W1	0.90	1.20	01
AA (BINA DEVI)	W	1.20	1.20	07

UnitBUA Table for Building -AA (BINA DEVI)

FLOOR	Name	UnitBUA Type	UnitBUA Area	Carpet Area	No. of Rooms	No. of Tenement
GROUND FLOOR PLAN	SPLIT FLAT A	FLAT	60.23	56.41	3	1
FIRST FLOOR PLAN	SPLIT FLAT A	FLAT	0.00	0.00	3	0
SECOND FLOOR PLAN	SPLIT FLAT A	FLAT	0.00	0.00	3	0
<b>Total:</b>	-	-	<b>60.23</b>	<b>56.41</b>	<b>9</b>	<b>1</b>

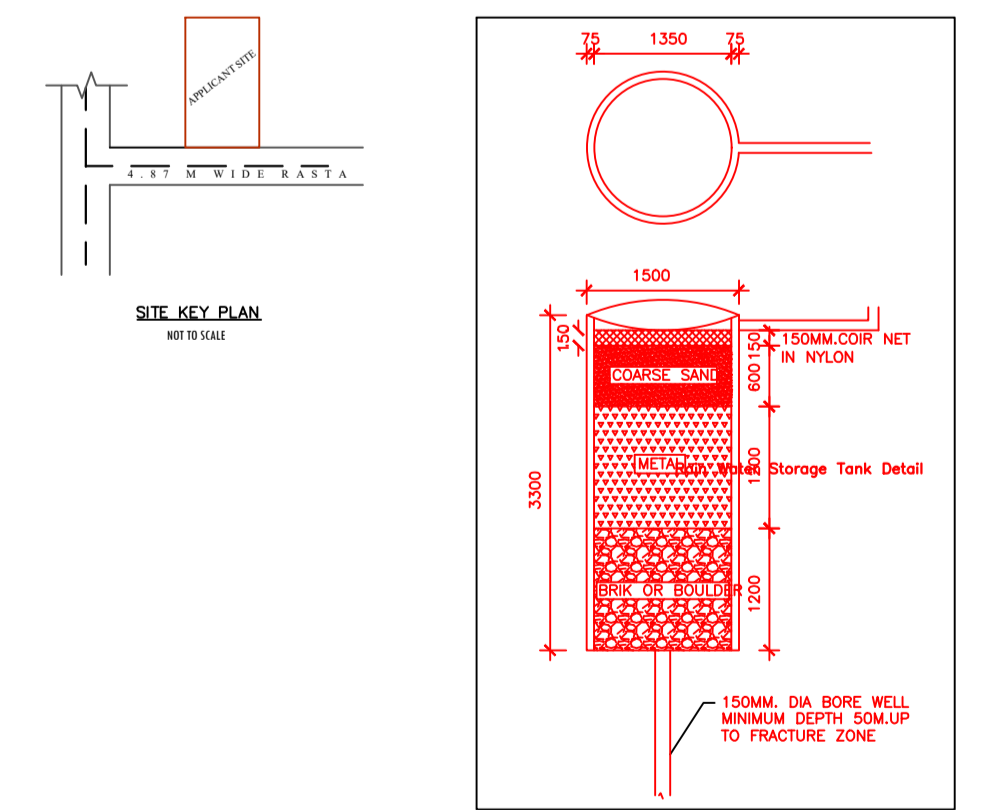

Buildingwise Floor FAR Details

Floor Name	Building Name AA (BINA DEVI)		Total	
	Proposed Built Up Area (Sq.mt.)	Proposed FAR Area (Sq.mt.)	Total Proposed Built Up Area (Sq.mt.)	Total FAR Area (Sq.mt.)
Ground Floor	29.69	29.69	29.69	29.69
First Floor	29.69	29.69	29.69	29.69
Second Floor	29.69	29.69	29.69	29.69
Terrace Floor	0.00	0.00	0.00	0.00
<b>Total :</b>	<b>89.07</b>	<b>89.07</b>	<b>89.07</b>	<b>89.07</b>

Building USE/SUBUSE Details

Building Name	Building Use	Building SubUse	Building Structure
AA (BINA DEVI)	Residential	Bungalow/ Dwelling / Non Apartment	Non-Highrise

LTP NAME AND SIGNATURE	STRUCTURAL ENG'S NAME AND SIGNATURE	BUILDER NAME AND SIGNATURE	DIGITAL SIGNATURE
MD SHOAB ALAM JNP/ENG/0001/2017			