

Proposal Basic Information

Proposal File No.	JNP/BP/0044/W14/2022
Owner Name	SMT BHARJAWATI DEVI
Khata No	381,1213
Plot No	7162,7164
Village Name	Tilaiya
Use	Residential
SubUse	Bungalow/ Dwelling / Non Apartment

FAR & Tenement Details (Table 4c-1)

Building	No. of Same Bldg	Total Built Up Area (Sq.mt.)	Proposed FAR Area (Sq.mt.) Resi.	Total FAR Area (Sq.mt.)	Total Consumed Additional FAR Area (Sq.mt.)	Tnmt (No.)
A (BHARJAWATI DEVI)	1	89.07	89.07	89.07	89.07	01
Grand Total :	1	89.07	89.07	89.07	89.07	01

AREA STATEMENT	VERSION NO. : 1.0.62
JHUMRITILAIYA NAGAR PARISHAD	VERSION DATE: 16/10/2020
PROJECT DETAIL:	
Region: JHARKHAND URBAN LOCAL BODIES	Plot Use: Residential
District: KODERMA	Plot SubUse: Bungalow/ Dwelling / Non Apartment
Authority: JHUMRITILAIYA NAGAR PARISHAD	PlotNearbyReligiousStructure: NA
Inward No: JNP/BP/0044/W14/2022	PlotSubPlot No: 7162,7164
Application Type: General Proposal	North: Plot No. - SMT MANITA DEVI
Project Type: Building Permission	South: Plot No. - SMT BINA DEVI
Nature of Development: New	East: Plot No. - NAWAL KISHOR DARUKA
Location of Development Area: Old Area	West: Road Width - 4.88M WIDE ROAD
AREA DETAILS:	SQ.MT.
AREA OF PLOT (Minimum)	(A) 53.48
NET AREA OF PLOT(Gross Plot Area - Deduction from Gross Plot area)	(A-Deductions) 53.48
Deduction for Balance Plot Area(from Gross Plot Area)	
Common Plot	7.01
Total	7.01
BALANCE AREA OF PLOT(Net Plot Area - Recreational/Amenity space)	(A-Deductions) 46.47
PLOT AREA FOR COVERAGE(Net Plot Area)	(A-Deductions) 53.48
Plot Area for FAR (Net Plot Area + Road Widening Area)	(A-Deductions) 53.48
COVERAGE CHECK	
Permissible Coverage area (70.00 %)	37.44
Proposed Coverage Area (55.52 %)	29.69
Total Prop. Coverage Area (55.52 %)	29.69
Balance coverage area (14.49 %)	7.75
FAR CHECK	
Perm. FAR Area (1.80)	96.26
Total Perm. FAR area	96.26
Residential FAR	89.08
Proposed FAR Area	89.08
Total Proposed FAR Area	89.08
Consumed FAR (Factor)	1.67
Balance FAR Area	7.18
BUILT UP AREA CHECK	
Total Proposed BuiltUp Area	89.07
ARCHITECT (Regd)	MD SHOAB ALAM
ENGINEER (Regd)	
SUPERVISOR (Regd)	
OWNER (Regd)	SMT BHARJAWATI DEVI
DEVELOPMENT AUTHORITY	LOCAL BODY

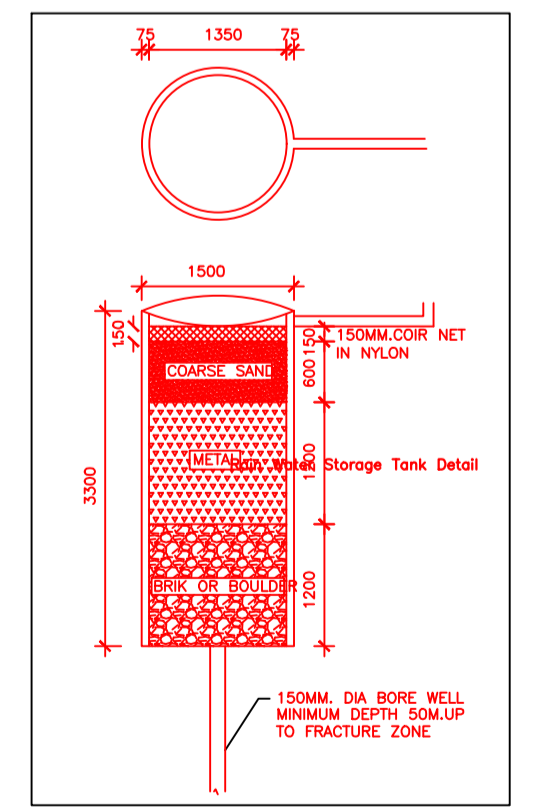
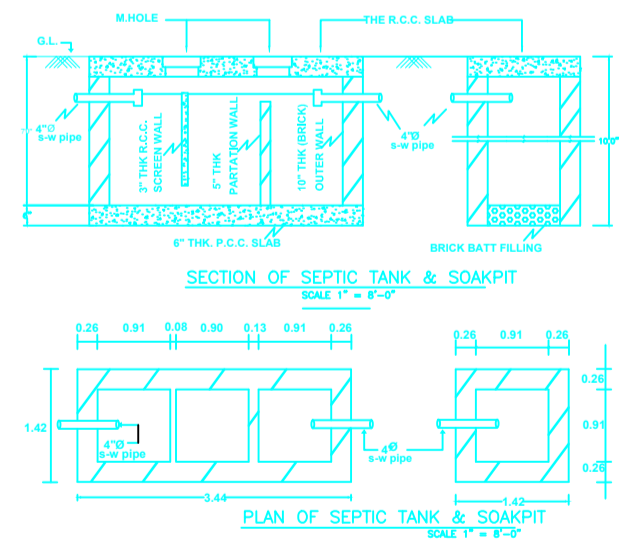
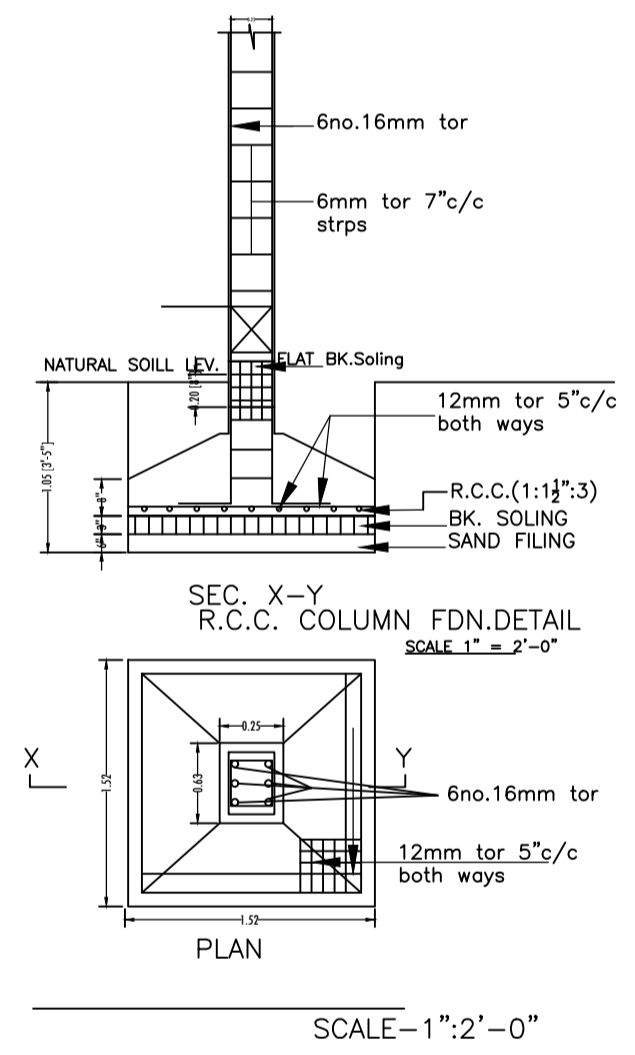
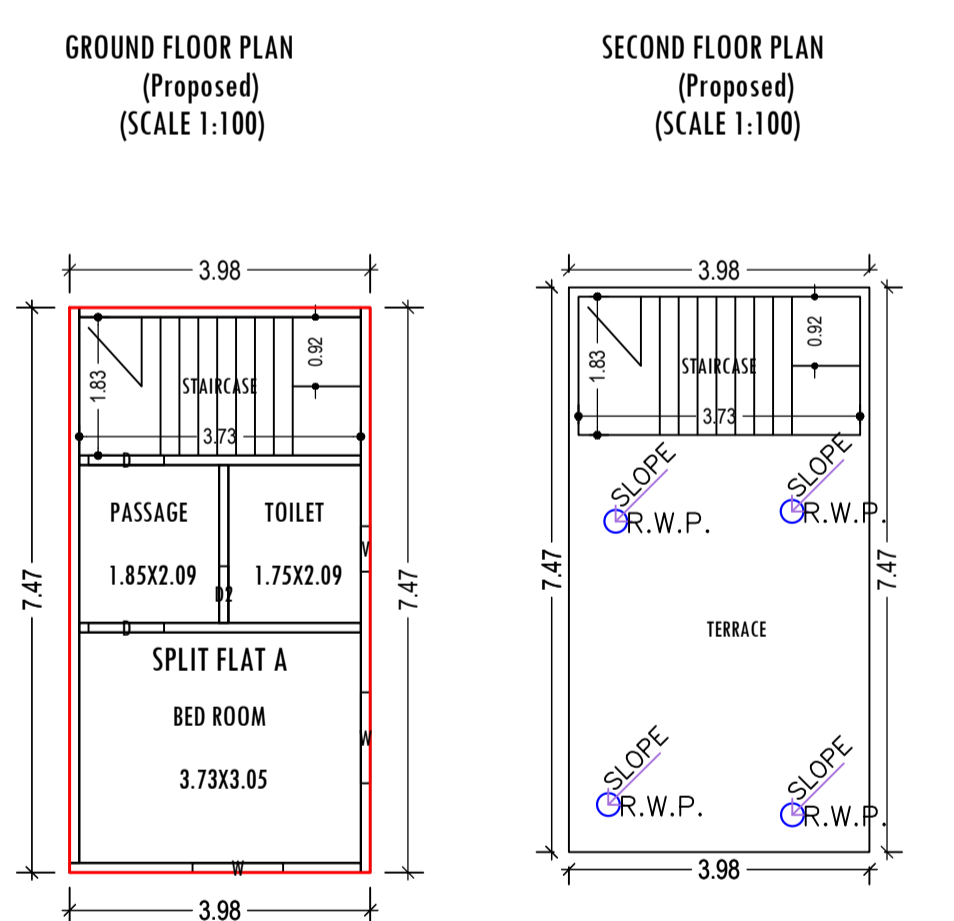
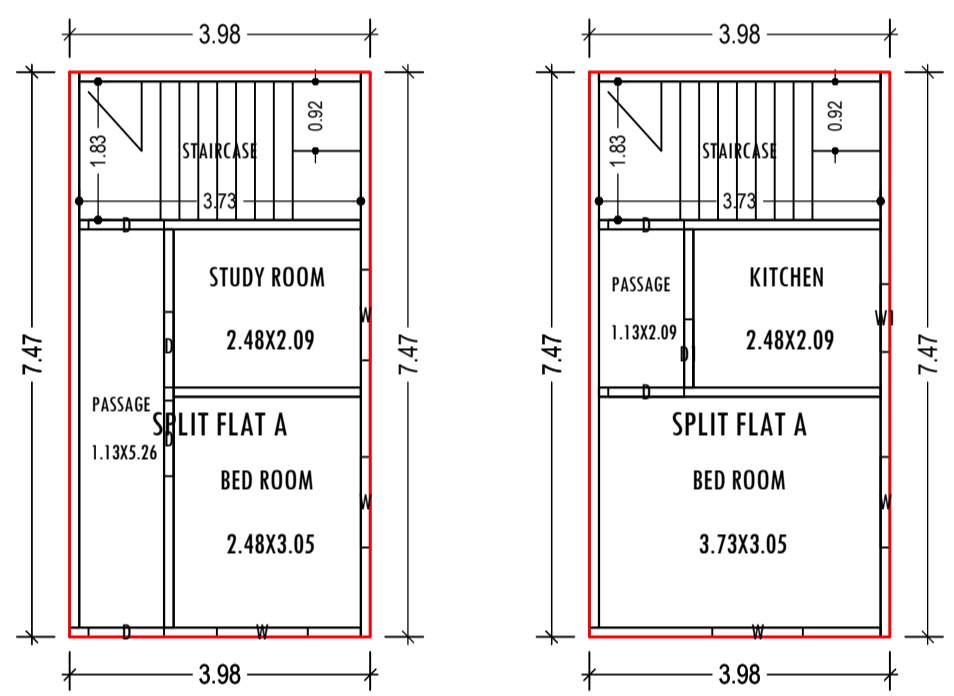
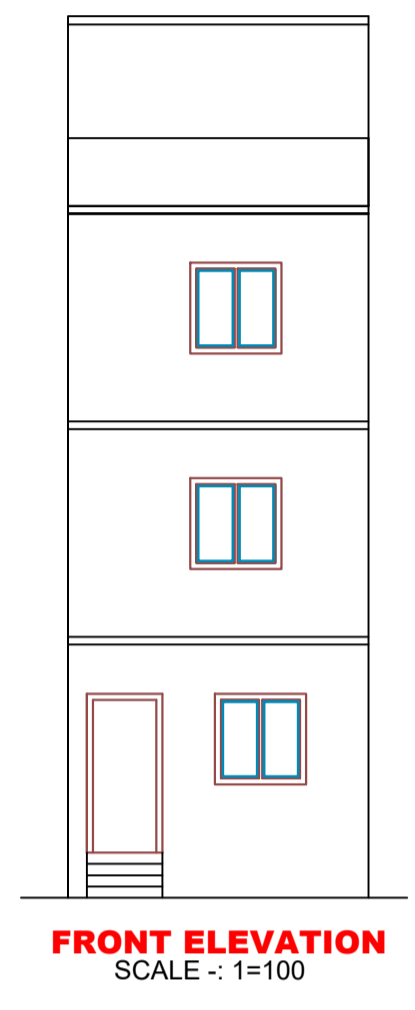
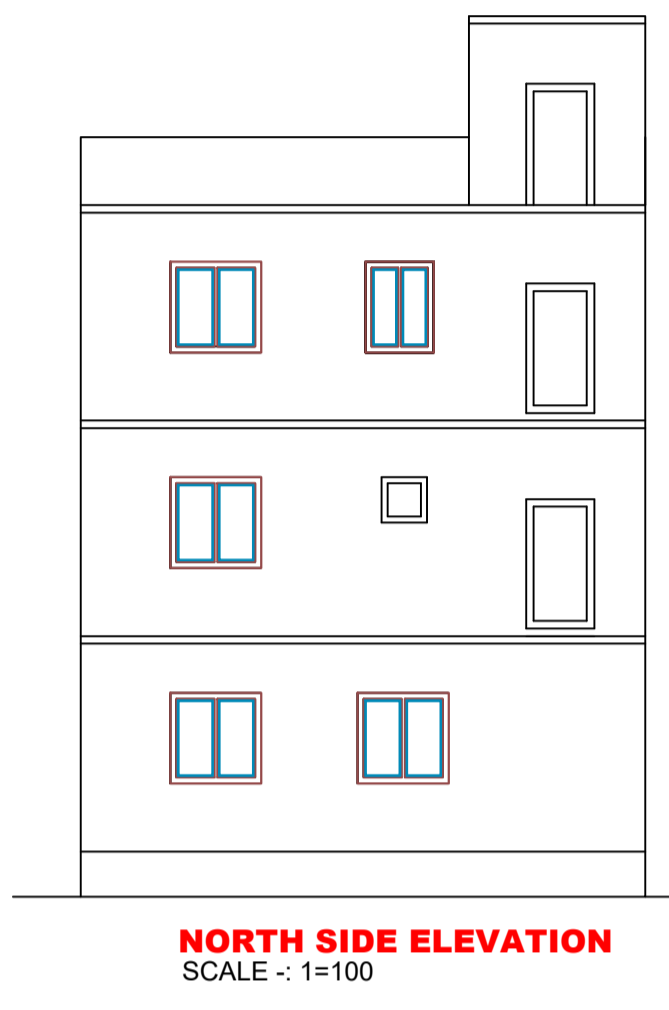
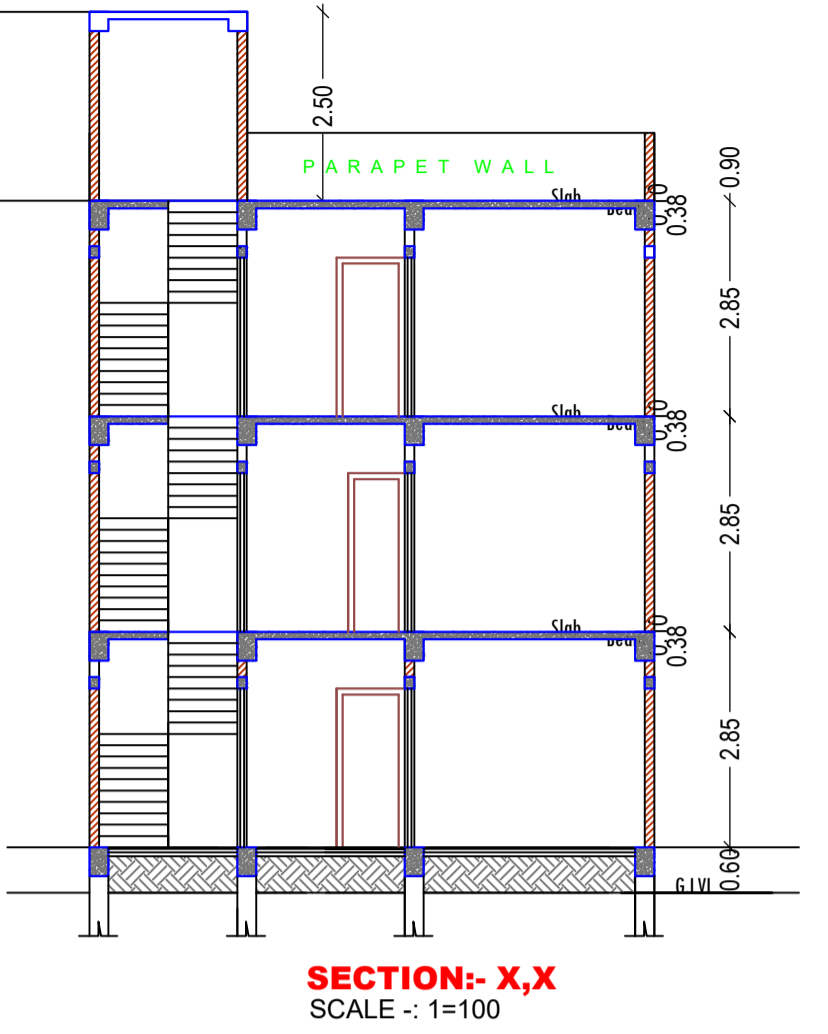
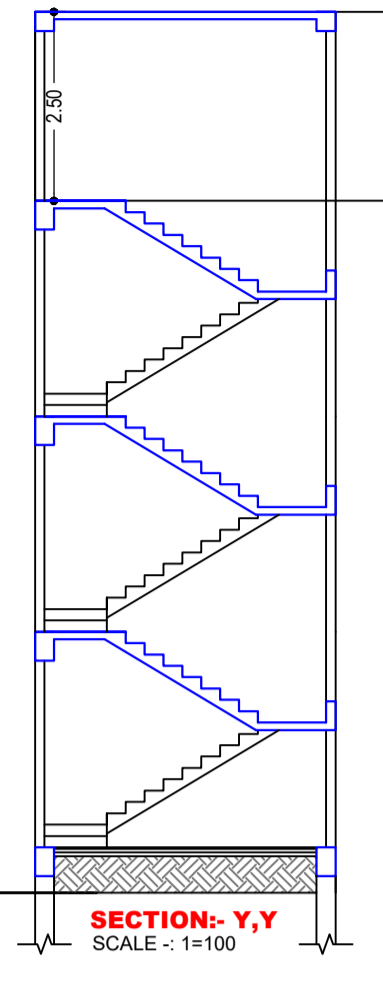
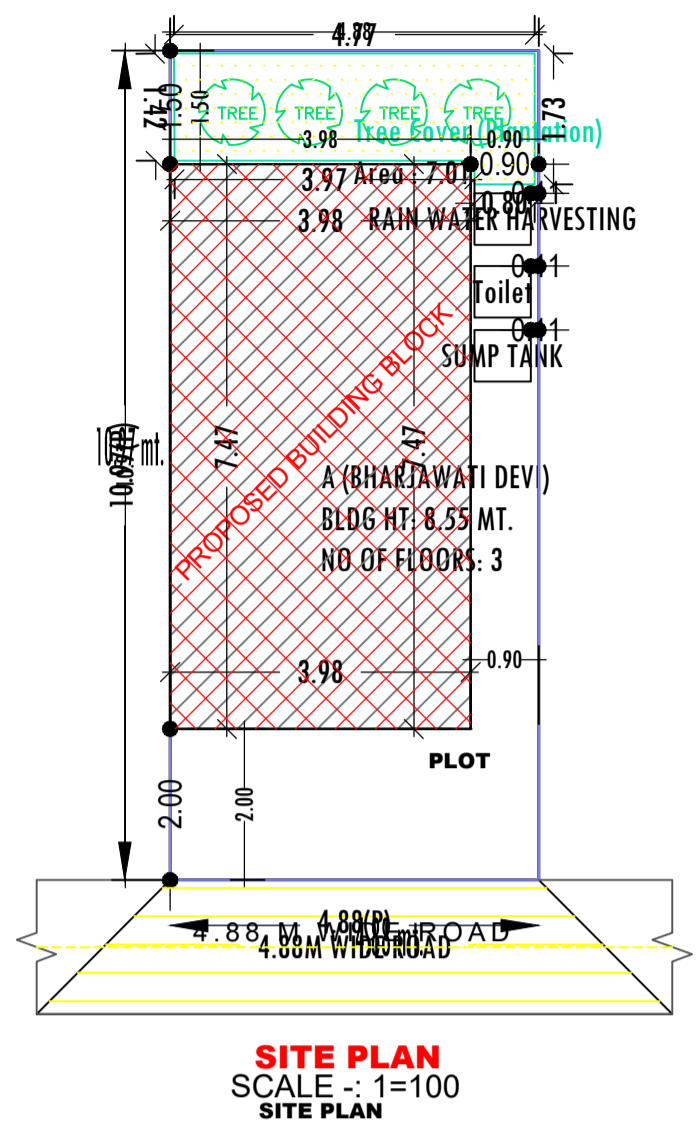

COLOR INDEX

PLOT BOUNDARY	Black
ABUTTING ROAD	Red
PROPOSED CONSTRUCTION	Green
COMMON PLOT	Yellow
ROAD WIDENING AREA	Blue
EXISTING (To be retained)	Light Blue
EXISTING (To be demolished)	White

Buildingwise Floor FAR Details

Floor Name	Building Name A (BHARJAWATI DEVI)		Total	
	Proposed Built Up Area (Sq.mt.)	Proposed FAR Area (Sq.mt.)	Total Proposed Built Up Area (Sq.mt.)	Total FAR Area (Sq.mt.)
Ground Floor	29.69	29.69	29.69	29.69
First Floor	29.69	29.69	29.69	29.69
Second Floor	29.69	29.69	29.69	29.69
Terrace Floor	0.00	0.00	0.00	0.00
Total :	89.07	89.07	89.07	89.07

Building USE/SUBUSE Details

Building Name	Building Use	Building SubUse	Building Structure
A (BHARJAWATI DEVI)	Residential	Bungalow/ Dwelling / Non Apartment	Non-Highrise

SCHEDULE OF DOOR:

BUILDING NAME	NAME	LENGTH	HEIGHT	NOS
A (BHARJAWATI DEVI)	D2	0.75	2.10	01
A (BHARJAWATI DEVI)	D1	0.90	2.10	01
A (BHARJAWATI DEVI)	D	1.00	2.10	01
A (BHARJAWATI DEVI)	D	1.00	2.13	07

SCHEDULE OF WINDOW/VENTILATION:

BUILDING NAME	NAME	LENGTH	HEIGHT	NOS
A (BHARJAWATI DEVI)	V	0.60	0.60	01
A (BHARJAWATI DEVI)	W1	0.90	1.20	01
A (BHARJAWATI DEVI)	W	1.20	1.20	07

UnitBUA Table for Building -A (BHARJAWATI DEVI)

FLOOR	Name	UnitBUA Type	UnitBUA Area	Carpet Area	No. of Rooms	No. of Tenement
GROUND FLOOR PLAN	SPLIT FLAT A	FLAT	60.23	56.41	3	1
FIRST FLOOR PLAN	SPLIT FLAT A	FLAT	0.00	0.00	3	0
SECOND FLOOR PLAN	SPLIT FLAT A	FLAT	0.00	0.00	3	0
Total:	-	-	60.23	56.41	9	1

Building -A (BHARJAWATI DEVI)

Floor Name	Total Built Up Area (Sq.mt.)	Proposed FAR Area (Sq.mt.)	Total FAR Area (Sq.mt.)	Total Consumed Additional FAR Area (Sq.mt.)	Tnmt (No.)
Ground Floor	29.69	29.69	29.69	29.69	01
First Floor	29.69	29.69	29.69	29.69	00
Second Floor	29.69	29.69	29.69	29.69	00
Terrace Floor	0.00	0.00	0.00	0.00	00
Total :	89.07	89.07	89.07	89.07	01
Total Number of Same Buildings	1				
Total :	89.07	89.07	89.07	89.07	01

LTP NAME AND SIGNATURE	STRUCTURAL ENG'S NAME AND SIGNATURE	BUILDER NAME AND SIGNATURE	DIGITAL SIGNATURE
MD SHOAB ALAM JNP/ENG/001/2017			