

SITE PLAN
SCALE: - 1=100

SITE PLAN

FAR & Tenement Details (Table 4c-1)

Building	No. of Same Bldg	Gross Built Up Area (Sq.mt.)	Deductions From Gross BUJ/Area in Sq.mt.) Cutout	Total Built Up Area (Sq.mt.)	Deductions (Area in Sq.mt.) Parking	Proposed FAR Area (Sq.mt.) Resi.	Add Area in FAR (Sq.mt.) Stair	Total FAR Area (Sq.mt.)	Total Consumed Additional FAR Area (Sq.mt.)	Tnmt (No.)
A (SMT URMILA DEVI)	1	312.91	3.68	309.23	98.23	204.92	6.08	211.00	211.00	02
Grand Total :	1	312.91	3.68	309.23	98.23	204.92	6.08	211.00	211.00	02

Proposal Basic Information

Proposal File No.	JNP/BP/0045/W16/2022
Owner Name	SMT URMILA DEVI
Khata No	1314
Plot No	7677
Village Name	Tilaiya
Use	Residential
SubUse	Bungalow/ Dwelling / Non Apartment

Required Parking (Table 7a)

Building Name	Type	SubUse	Area (Sq.mt.)	Units		Car		Visitors Car			
				Reqd.	Prop.	Reqd./Unit	Reqd.	Prop.	Reqd./Unit	Reqd.	Prop.
A (SMT URMILA DEVI)	Residential	Bungalow/ Dwelling / Non Apartment	> 0	1	2.00	1	2	-	-	-	-
			> 0	1	2.00	-	-	1	1	-	-
Total :			-	-	-	-	2	2	-	1	1

Parking Check (Table 7b)

Vehicle Type	Reqd.		Prop.	
	No.	Area	No.	Area
Car	-	-	2	25.00
Total Car	2	25.00	2	25.00
Visitor's Car Parking	-	-	1	12.50
Total Visitor Parking	1	12.50	1	12.50
Other Parking	-	-	-	73.23
Total		37.50		110.73

AREA STATEMENT JHUMRITILAIYA NAGAR PARISHAD	VERSION NO. : 1.0.62 VERSION DATE: 16/10/2020
PROJECT DETAIL:	
Region: JHARKHAND URBAN LOCAL BODIES	Plot Use: Residential
District: KODERMA	Plot SubUse: Bungalow/ Dwelling / Non Apartment
Authority: JHUMRITILAIYA NAGAR PARISHAD	PlotNearby/ReligiousStructure: NA
Inward No: JNP/BP/0045/W16/2022	PlotSubPlot No: 7677
Application Type: General Proposal	North: Plot No. - BHANU PRATAP
Project Type: Building Permission	South: Plot No. - MANISHA SINGH
Nature of Development: New	East: Plot No. - AJAY KUMAR
Location of Development Area: Old Area	West: Road Width - 4.57M WIDE ROAD
AREA DETAILS:	SQ.MT.
AREA OF PLOT (Minimum)	(A) 158.39
NET AREA OF PLOT(Gross Plot Area - Deduction from Gross Plot area)	(A-Deductions) 158.39
Deduction for Balance Plot Area(from Gross Plot Area)	
Common Plot	17.27
BALANCE AREA OF PLOT(Net Plot Area - Recreational/Amenity space)	(A-Deductions) 141.11
PLOT AREA FOR COVERAGE(Net Plot Area)	(A-Deductions) 158.39
Plot Area for FAR (Net Plot Area + Road Widening Area)	(A-Deductions) 158.39
COVERAGE CHECK	
Permissible Coverage area (70.00 %)	110.87
Proposed Coverage Area (65.85 %)	104.30
Total Prop. Coverage Area (65.85 %)	104.30
Balance coverage area (4.15 %)	6.57
FAR CHECK	
Perm. FAR Area (1.50)	237.58
Total Perm. FAR area	237.58
Residential FAR	204.93
Proposed FAR Area	211.00
Total Proposed FAR Area	211.00
Consumed FAR (Factor)	1.33
Balance FAR Area	26.58
BUILT UP AREA CHECK	
Total Proposed BuiltUp Area	309.23
ARCHITECT (Regd)	MD SHOAB ALAM
ENGINEER (Regd)	
SUPERVISOR (Regd)	
OWNER (Regd)	SMT URMILA DEVI
DEVELOPMENT AUTHORITY	LOCAL BODY

COLOR INDEX	
PLOT BOUNDARY	Black
ABUTTING ROAD	Green
PROPOSED CONSTRUCTION	Red
COMMON PLOT	Yellow
ROAD WIDENING AREA	Orange
EXISTING (To be retained)	Blue
EXISTING (To be demolished)	Light Blue

Buildingwise Floor FAR Details

Floor Name	Building Name A (SMT URMILA DEVI)		Total	
	Proposed Built Up Area (Sq.mt.)	Proposed FAR Area (Sq.mt.)	Total Proposed Built Up Area (Sq.mt.)	Total FAR Area (Sq.mt.)
Ground Floor	104.31	6.08	104.31	6.08
First Floor	102.46	102.46	102.46	102.46
Second Floor	102.46	102.46	102.46	102.46
Terrace Floor	0.00	0.00	0.00	0.00
Total :	309.23	211.00	309.23	211.00

Building USE/SUBUSE Details

Building Name	Building Use	Building SubUse	Building Structure
A (SMT URMILA DEVI)	Residential	Bungalow/ Dwelling / Non Apartment	Non-Highrise

LTP NAME AND SIGNATURE	STRUCTURAL ENG'S NAME AND SIGNATURE	BUILDER NAME AND SIGNATURE	DIGITAL SIGNATURE
MD SHOAB ALAM JNP/ENG/001/2017			

DATE	23-06-2022
SHEET NO.	2
Proposal Basic Information	
Proposal File No.	JNP/IBP/0045/W16/2022
Owner Name	SMT URMILA DEVI
Khata No	1314
Plot No	7677
Village Name	Tilaiya
Use	Residential
SubUse	Bungalow/ Dwelling / Non Apartment

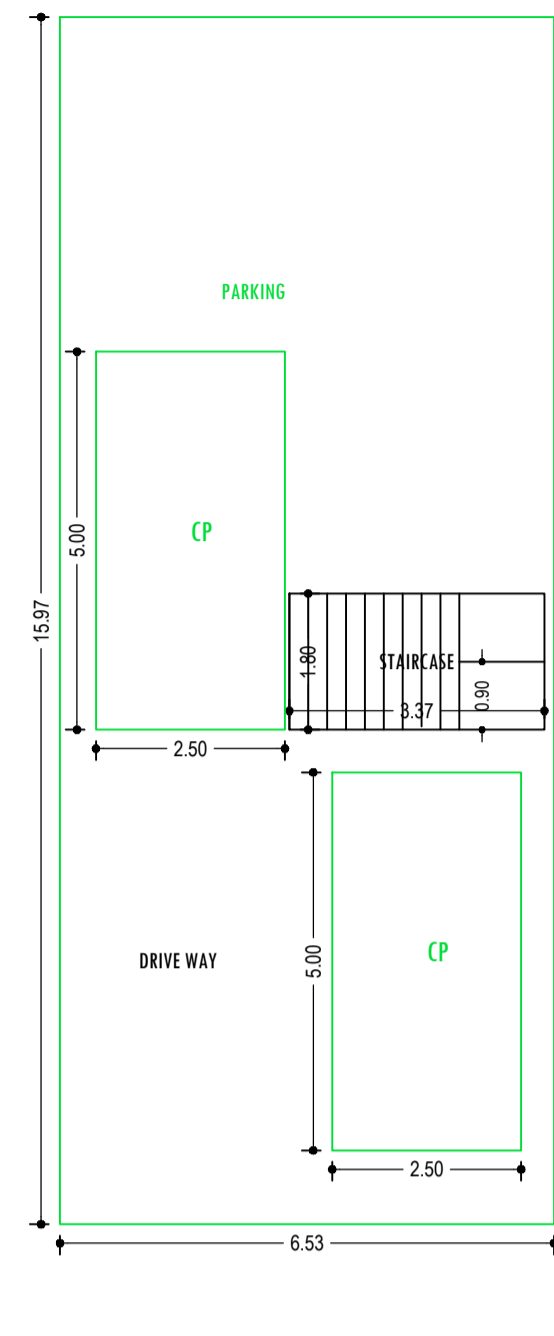

GROUND FLOOR PLAN (SCALE 1:100)

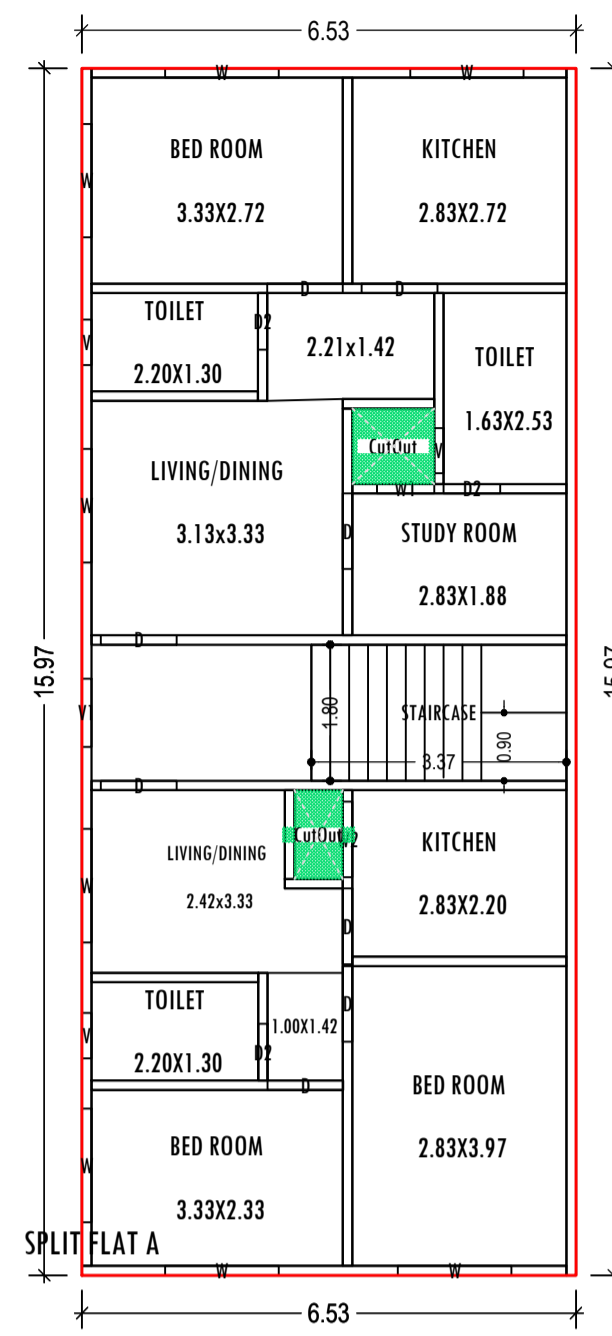

TYPICAL - 1 & 2 FLOOR PLAN (Proposed) (SCALE 1:100)

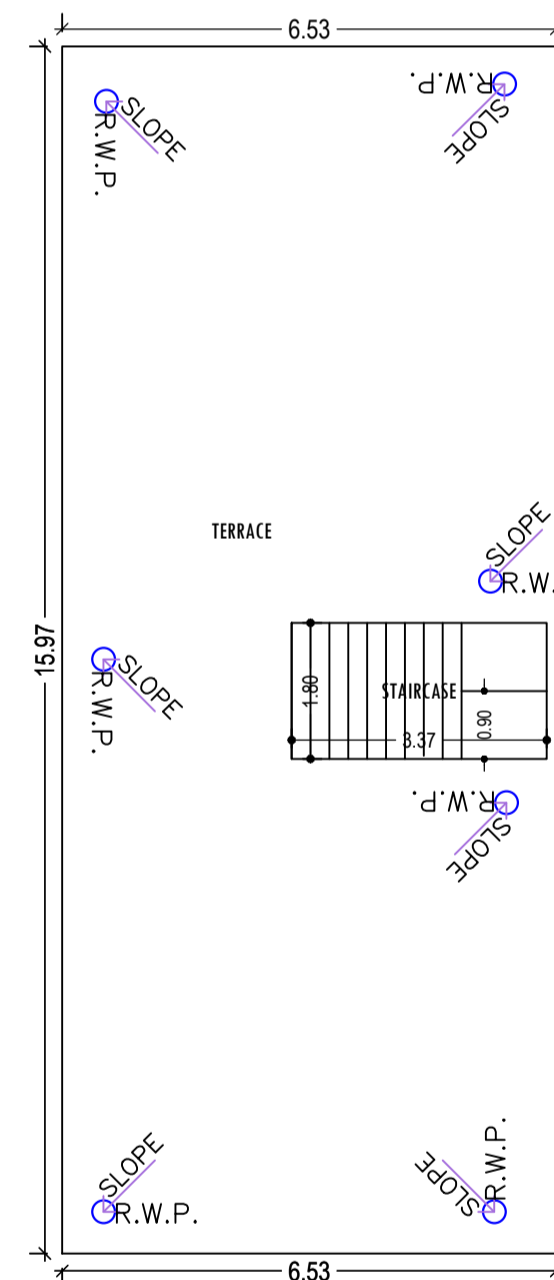

TERRACE FLOOR PLAN (SCALE 1:100)

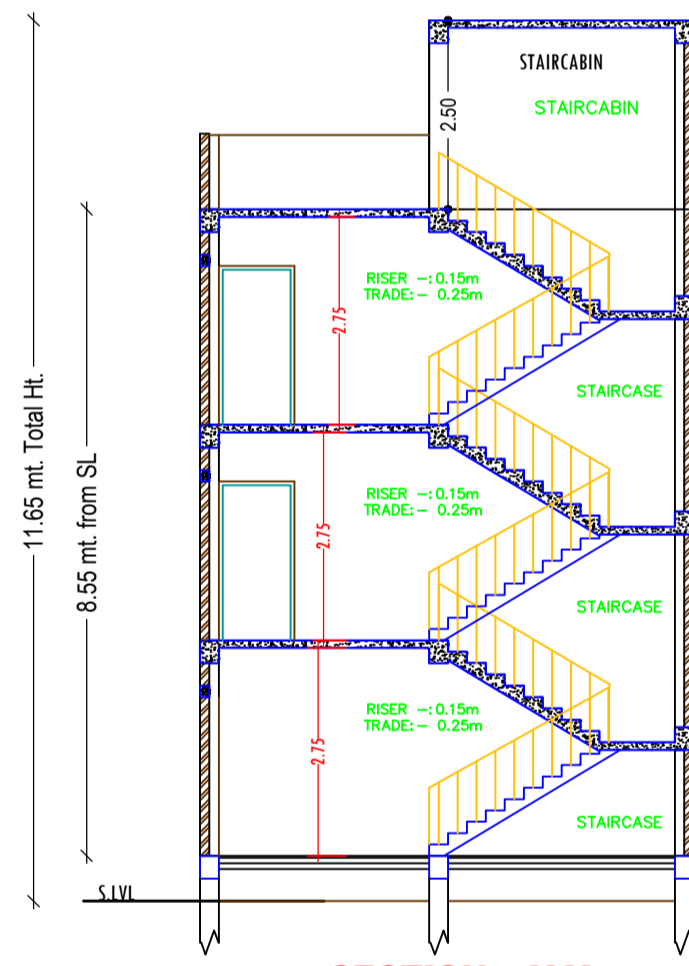

SECTION - Y,Y (SCALE 1:100)

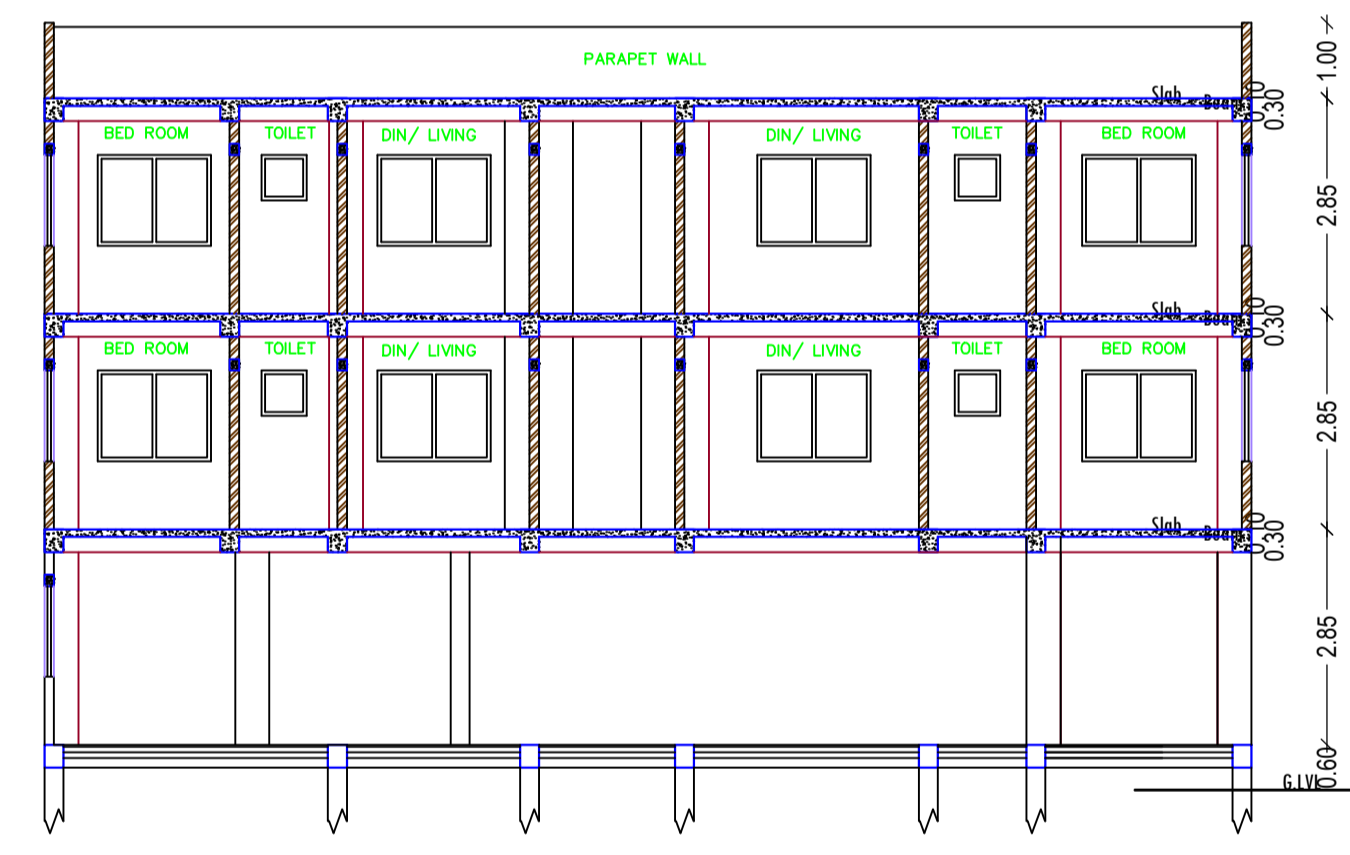

SECTION - X,X (SCALE 1:100)

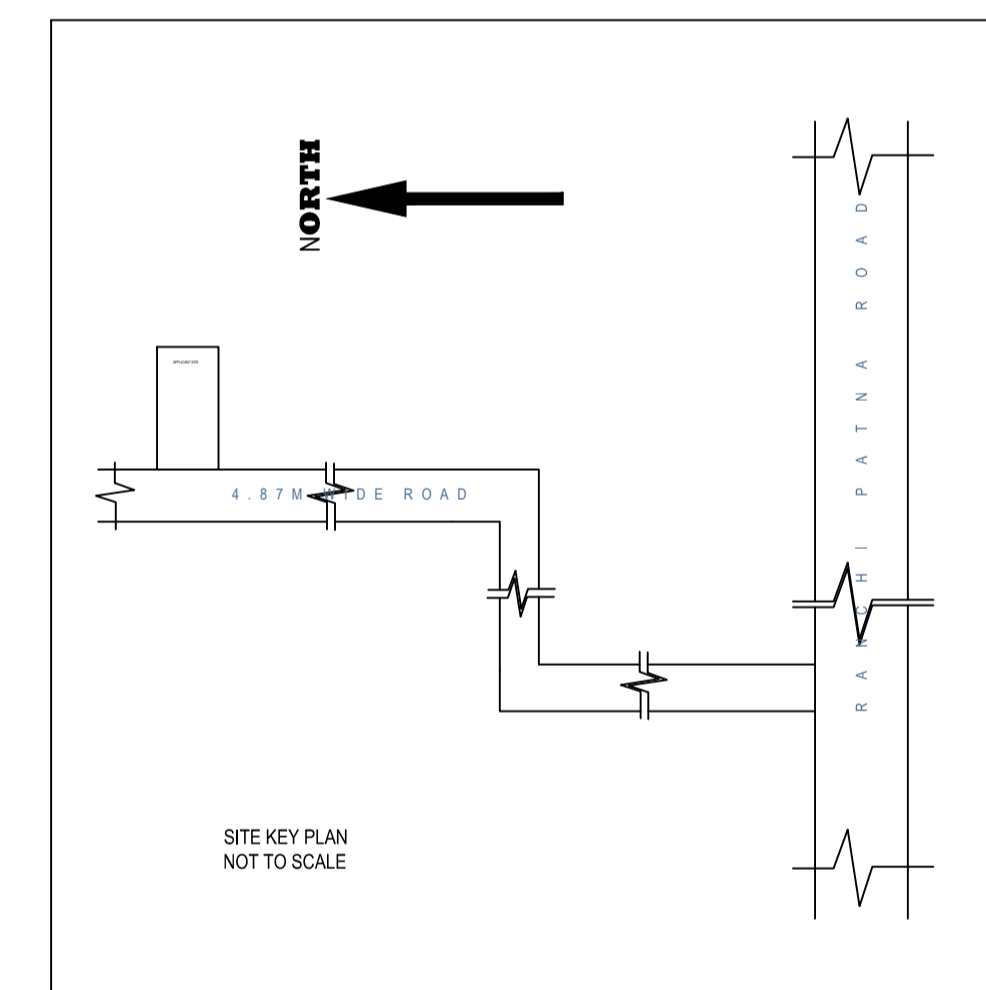

SITE KEY PLAN (NOT TO SCALE)

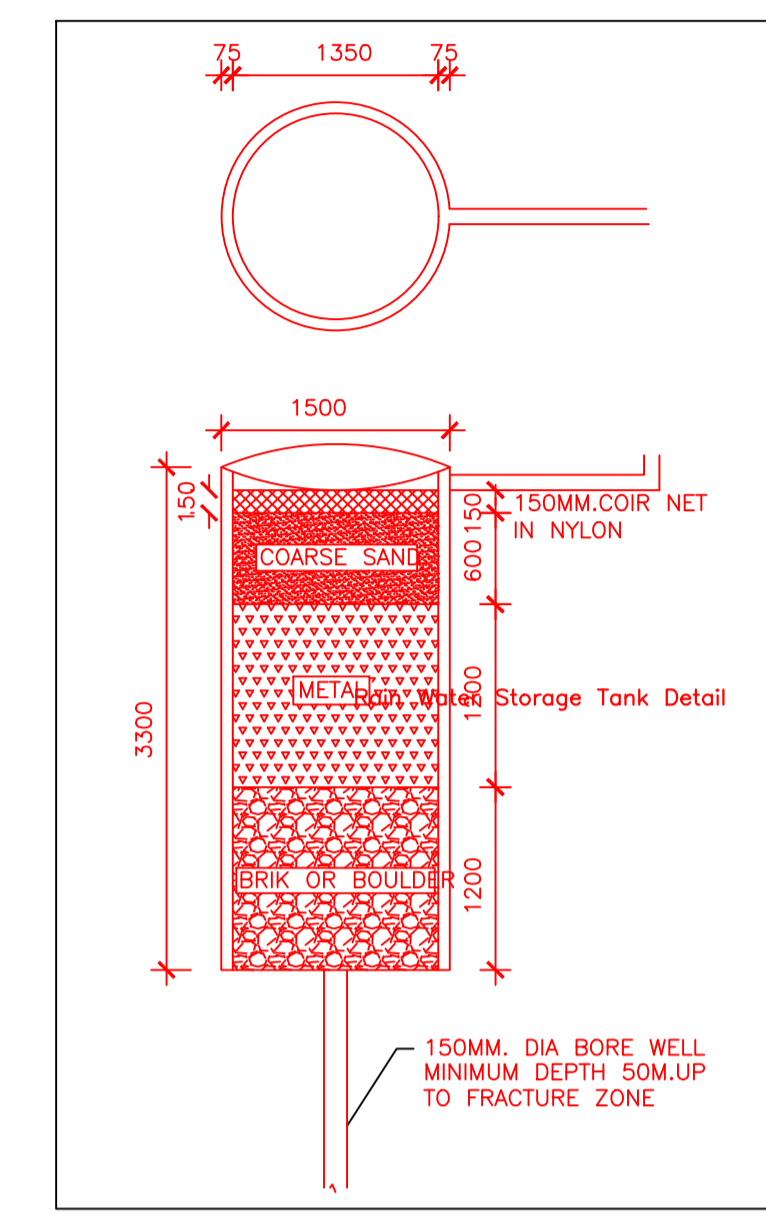

Storage Tank Detail

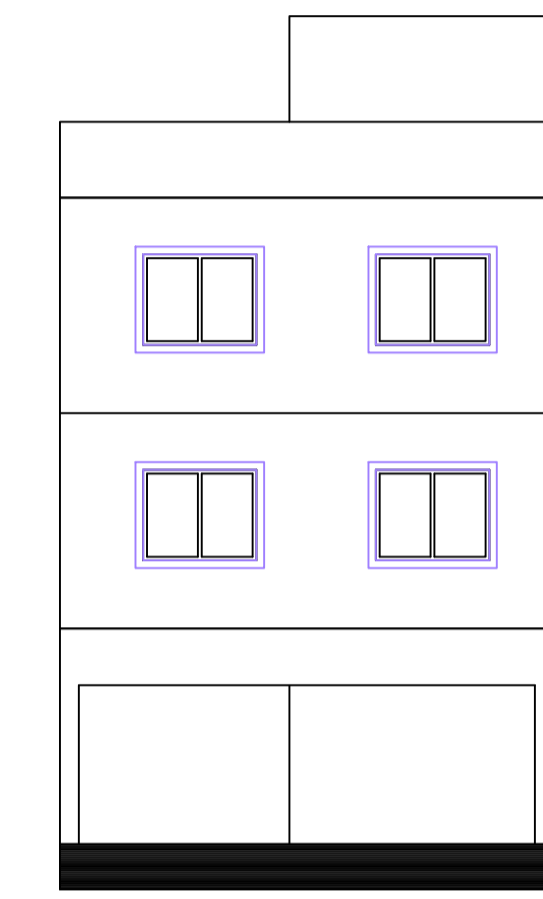

FRONT ELEVATION (SCALE 1:100)

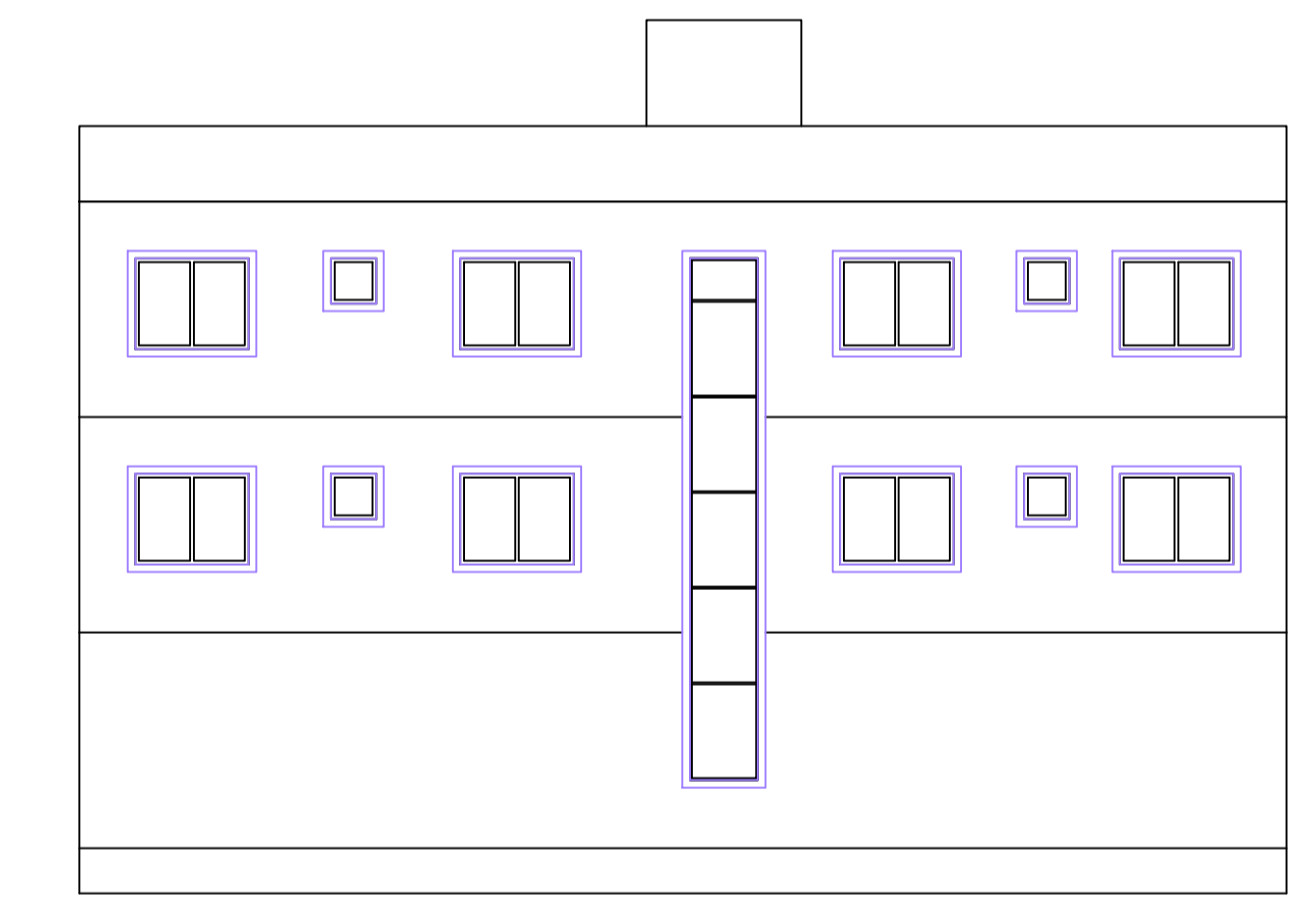

SIDE ELEVATION (SCALE 1:100)

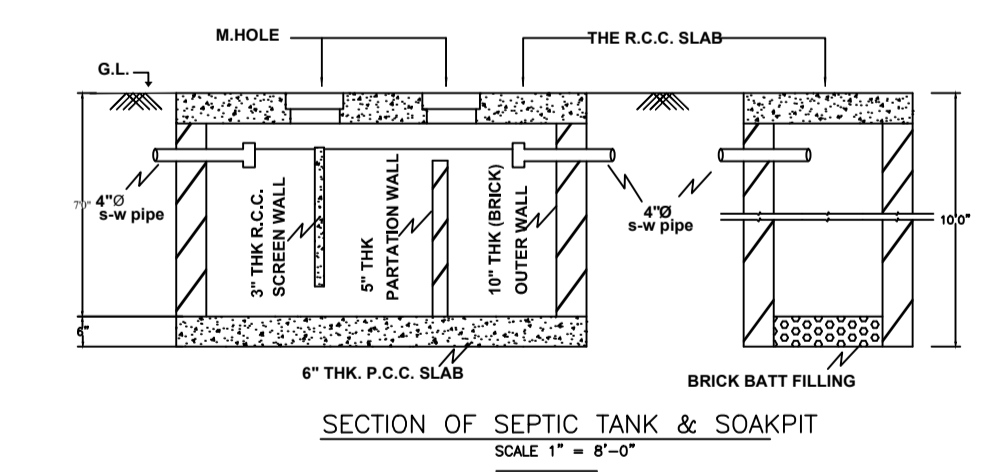

SECTION OF SEPTIC TANK & SOAKPIT (SCALE 1" = 8'-0")

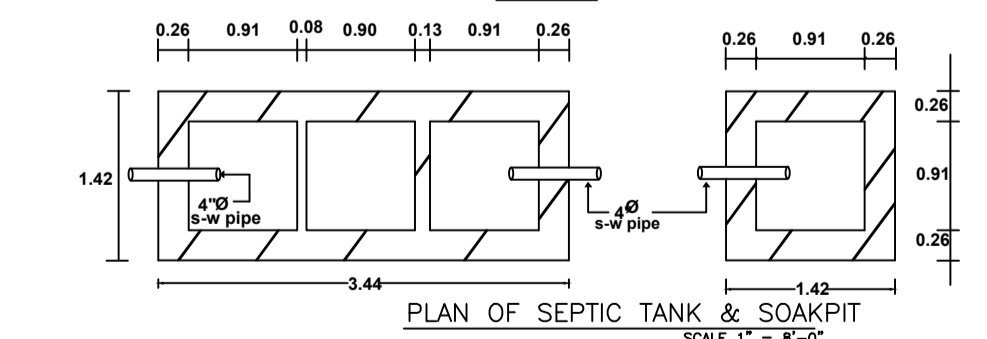

PLAN OF SEPTIC TANK & SOAKPIT (SCALE 1" = 8'-0")

Building -A (SMT URMILA DEVI)

Floor Name	Gross Builtup Area	Deductions From Gross BUA/Area in Sq.mt.		Total Built Up Area (Sq.mt.)	Deductions (Area in Sq.mt.)		Proposed FAR Area (Sq.mt.)	Add Area In FAR (Sq.mt.)	Total FAR Area (Sq.mt.)	Total Consumed Additional FAR Area (Sq.mt.)	Trmt (No.)
		Cutout	Parking		Resi.	Stair					
Ground Floor	104.31	0.00	104.31	98.23	0.00	6.08	6.08	6.08	00		
First Floor	104.30	1.84	102.46	0.00	102.46	0.00	102.46	102.46	01		
Second Floor	104.30	1.84	102.46	0.00	102.46	0.00	102.46	102.46	01		
Terrace Floor	0.00	0.00	0.00	0.00	0.00	0.00	0.00	0.00	00		
Total :	312.91	3.68	309.23	98.23	204.92	6.08	211.00	211.00	02		
Total Number of Same Buildings	1										
Total :	312.91	3.68	309.23	98.23	204.92	6.08	211.00	211.00	02		

SCHEDULE OF DOOR:

BUILDING NAME	NAME	LENGTH	HEIGHT	NOS
A (SMT URMILA DEVI)	D2	0.75	2.13	06
A (SMT URMILA DEVI)	D	1.00	2.13	16

SCHEDULE OF WINDOW/VENTILATION:

BUILDING NAME	NAME	LENGTH	HEIGHT	NOS
A (SMT URMILA DEVI)	V	0.60	0.60	06
A (SMT URMILA DEVI)	W1	0.76	1.20	02
A (SMT URMILA DEVI)	W2	1.00	1.20	02
A (SMT URMILA DEVI)	W	1.50	1.20	16

UnitBUA Table for Building -A (SMT URMILA DEVI)

FLOOR	Name	UnitBUA Type	UnitBUA Area	Carpet Area	No. of Rooms	No. of Tenement
TYPICAL - 1 & 2 FLOOR PLAN	SPLIT FLAT A	FLAT	90.83	84.23	11	2
Total:	-	-	181.65	168.46	22	2

LTP NAME AND SIGNATURE	STRUCTURAL ENG'S NAME AND SIGNATURE	BUILDER NAME AND SIGNATURE	DIGITAL SIGNATURE
MD SHOAIB ALAM JNP/ENG/001/2017			

Proposal Basic Information	
Proposal File No.	JNP/EP/0045/W16/2022
Owner Name	SMT URMILA DEVI
Khata No	1314
Plot No	7677
Village Name	Tilaiya
Use	Residential
SubUse	Bungalow/ Dwelling / Non Apartment

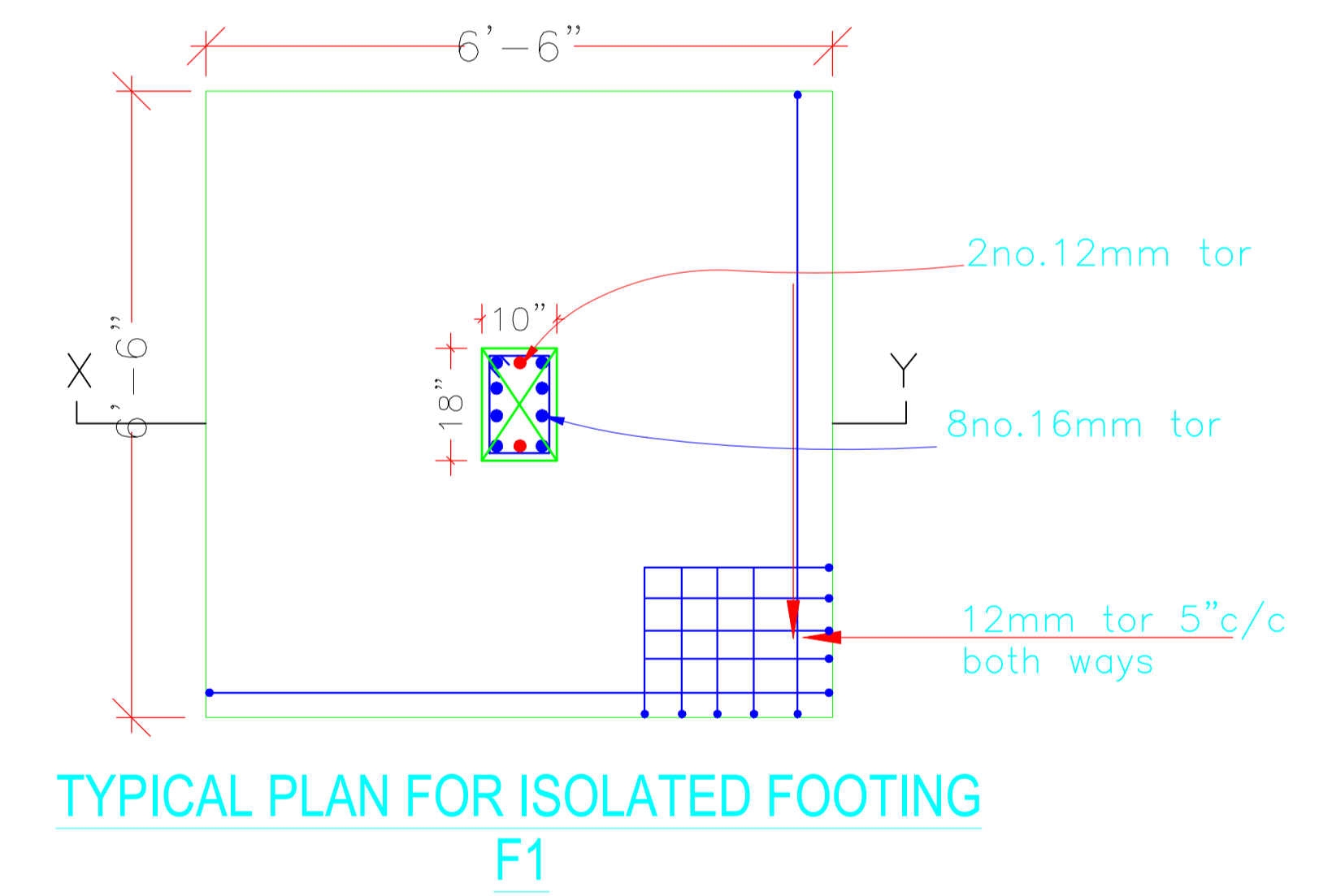
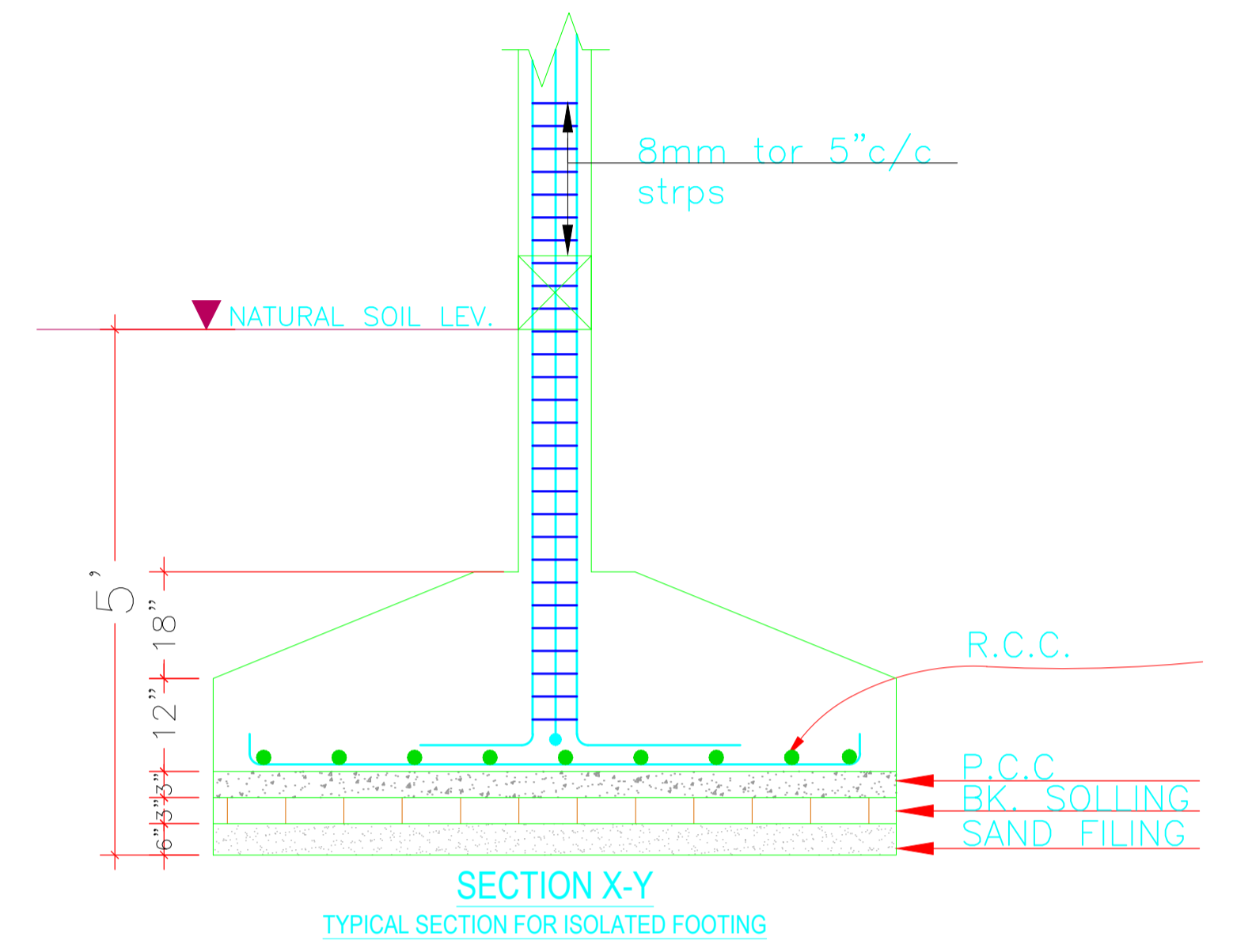

LTP NAME AND SIGNATURE	STRUCTURAL ENG'S NAME AND SIGNATURE	BUILDER NAME AND SIGNATURE	DIGITAL SIGNATURE
MD. SHOAIB ALAM JNP/ENG/0001/2017			