

Project Title - PLOT NO.1052 OWNER MR. SURESH KUMAR

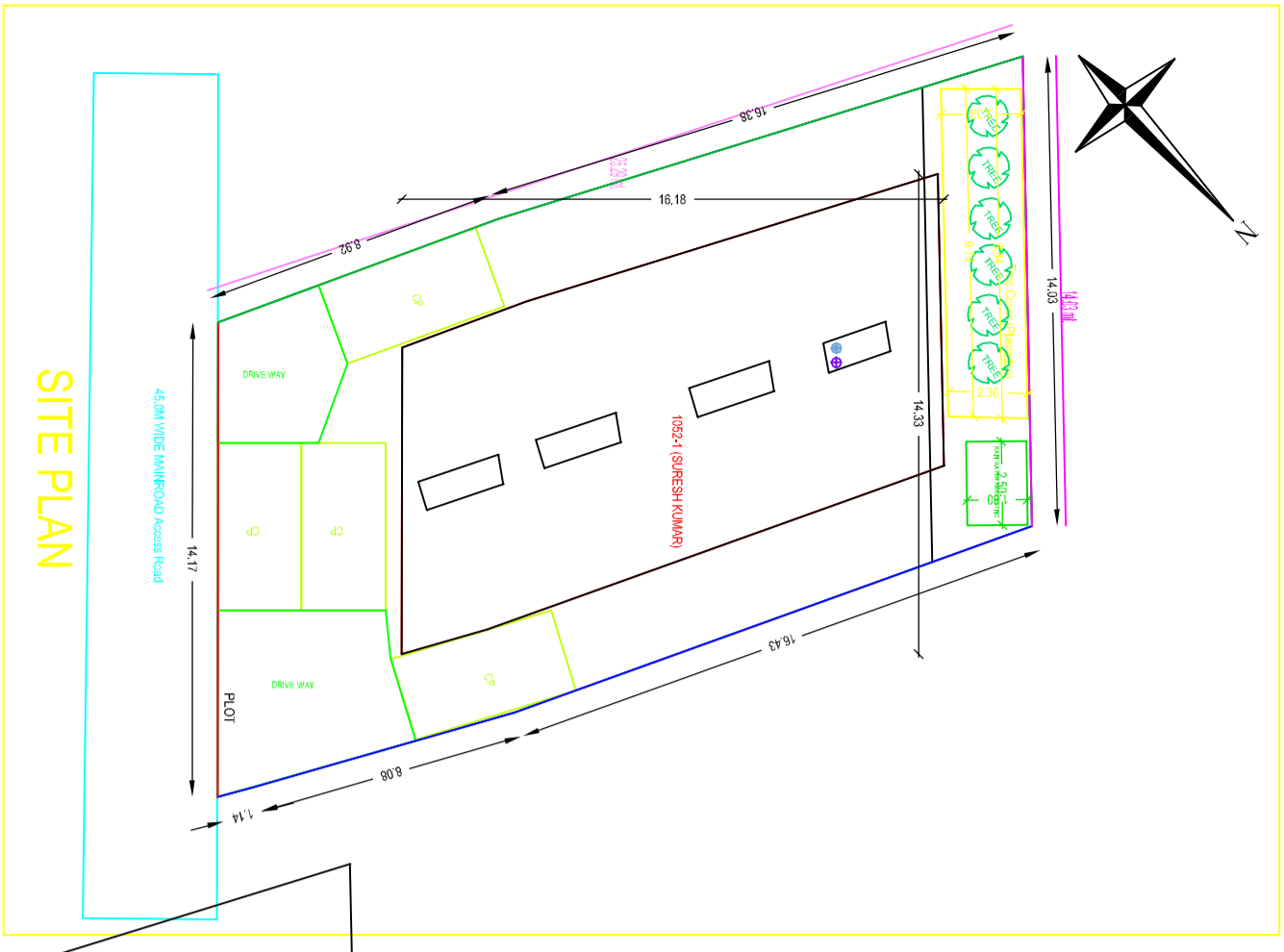

SITE PLAN

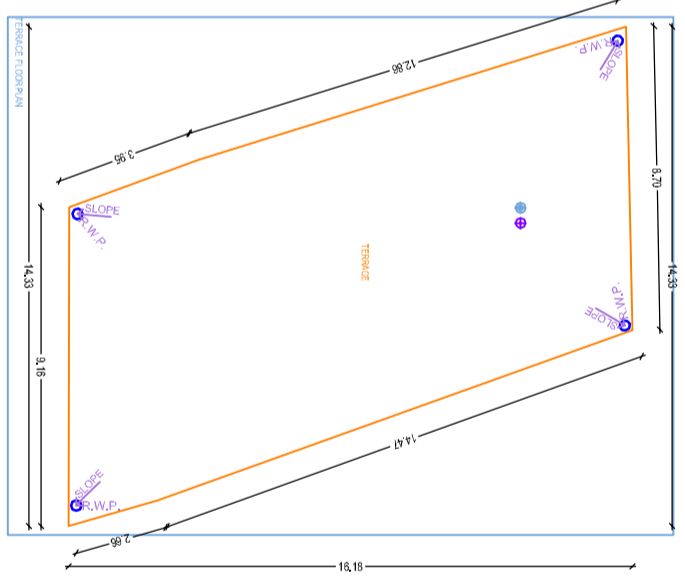
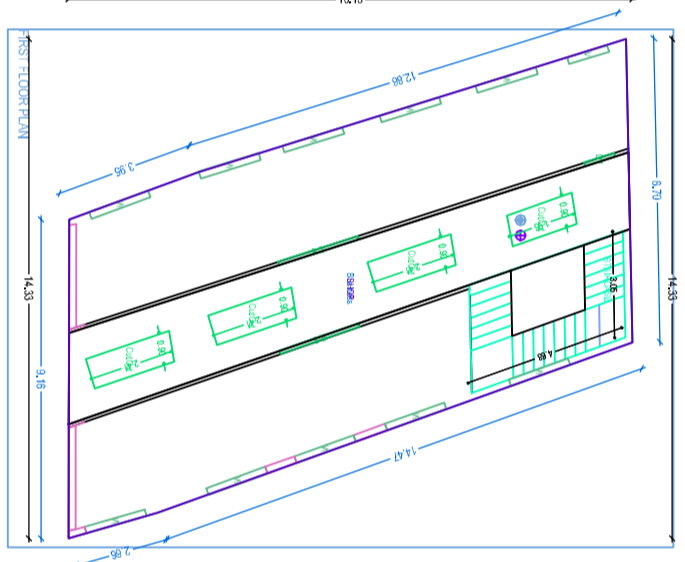
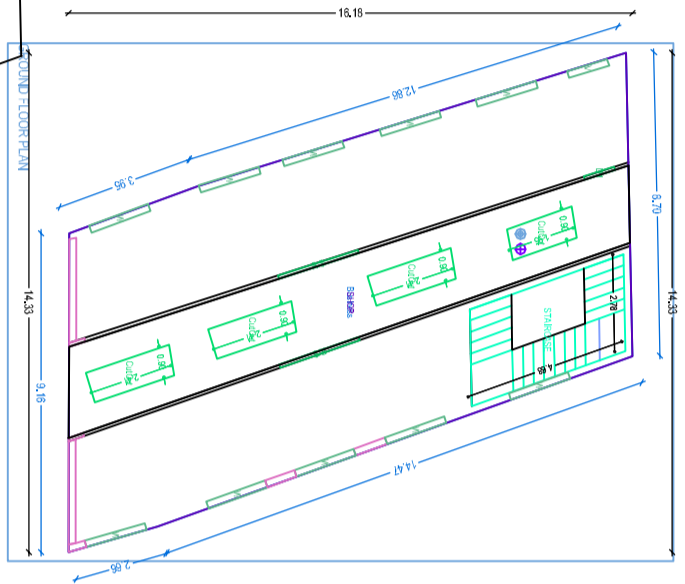
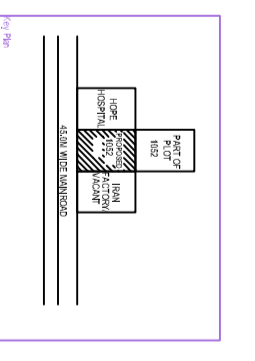
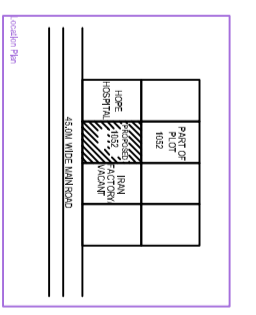
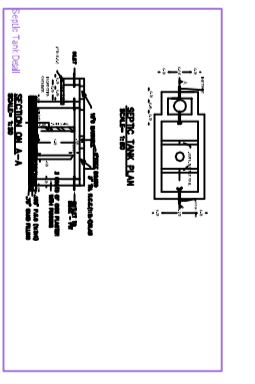
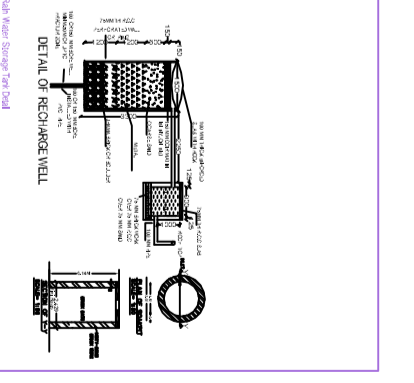
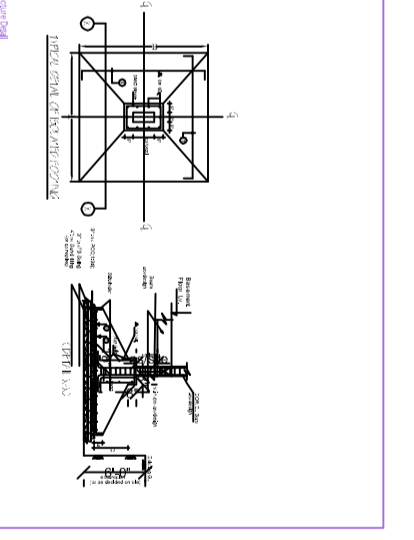
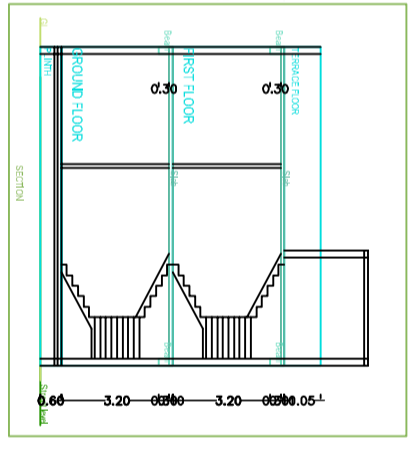
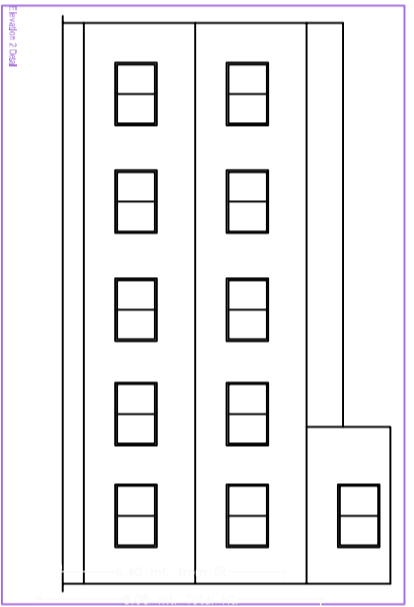
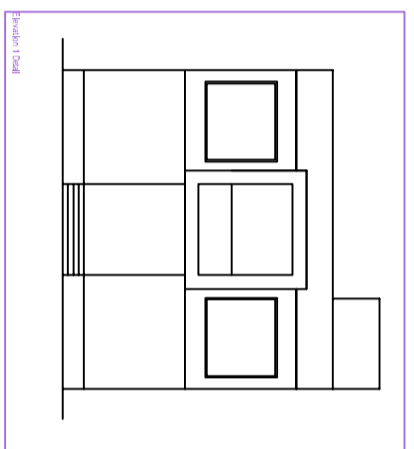
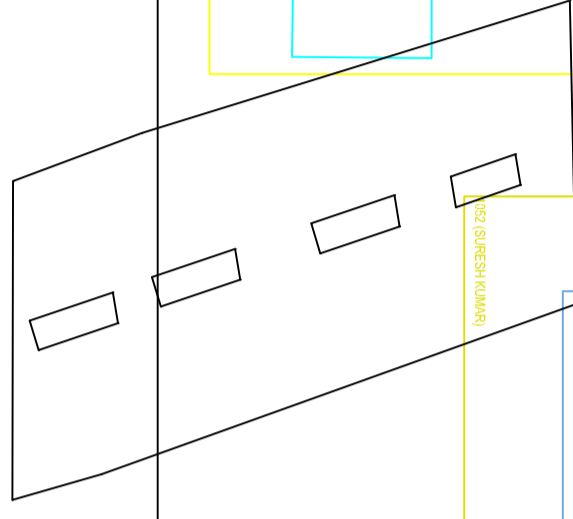

**PROPERTY INFO (SURESH KUMAR)**

PROPERTY INFO	DESCRIPTION	UNIT	MEASUREMENT	REMARKS
Plot Area	14.30	Sq. M	14.30	
Building Area	14.30	Sq. M	14.30	
Plot Ratio	1.00	-	-	
Plot Orientation	North	-	-	

**SCHEDULE OF WORKS**

ITEM NO.	DESCRIPTION	UNIT	QUANTITY	ESTIMATED COST
1	Excavation	Sq. M	14.30	14300
2	Foundation	Sq. M	14.30	14300
3	Structure	Sq. M	14.30	14300
4	Roofing	Sq. M	14.30	14300
5	Interior	Sq. M	14.30	14300
6	Exterior	Sq. M	14.30	14300

**SCHEDULE OF WORKS**

ITEM NO.	DESCRIPTION	UNIT	QUANTITY	ESTIMATED COST
7	Water Supply	Sq. M	14.30	14300
8	Sanitation	Sq. M	14.30	14300
9	Electrical	Sq. M	14.30	14300
10	Painting	Sq. M	14.30	14300
11	Landscaping	Sq. M	14.30	14300
12	Final Handover	Sq. M	14.30	14300

**PROPERTY INFO (SURESH KUMAR)**

PROPERTY INFO	DESCRIPTION	UNIT	MEASUREMENT	REMARKS
Plot Area	14.30	Sq. M	14.30	
Building Area	14.30	Sq. M	14.30	
Plot Ratio	1.00	-	-	
Plot Orientation	North	-	-	

DATE: 10/10/2023

SCALE: 1:100

PROJECT NO: 1052

OWNER: MR. SURESH KUMAR

DESIGNER: ARCHITECT

CONTRACT NO: 1052

DATE OF ISSUE: 10/10/2023

PROJECT LOCATION: 1052

CLIENT: MR. SURESH KUMAR

DESIGNER: ARCHITECT

CONTRACT NO: 1052

DATE OF ISSUE: 10/10/2023

PROJECT LOCATION: 1052

CLIENT: MR. SURESH KUMAR

DESIGNER: ARCHITECT

CONTRACT NO: 1052

DATE OF ISSUE: 10/10/2023

PROJECT LOCATION: 1052

CLIENT: MR. SURESH KUMAR

DESIGNER: ARCHITECT

CONTRACT NO: 1052

DATE OF ISSUE: 10/10/2023

PROJECT LOCATION: 1052

CLIENT: MR. SURESH KUMAR

DESIGNER: ARCHITECT

CONTRACT NO: 1052

DATE OF ISSUE: 10/10/2023

PROJECT LOCATION: 1052

CLIENT: MR. SURESH KUMAR

DESIGNER: ARCHITECT

CONTRACT NO: 1052

DATE OF ISSUE: 10/10/2023

PROJECT LOCATION: 1052

CLIENT: MR. SURESH KUMAR

DESIGNER: ARCHITECT

CONTRACT NO: 1052

DATE OF ISSUE: 10/10/2023

PROJECT LOCATION: 1052

CLIENT: MR. SURESH KUMAR

DESIGNER: ARCHITECT

CONTRACT NO: 1052

DATE OF ISSUE: 10/10/2023

PROJECT LOCATION: 1052

CLIENT: MR. SURESH KUMAR

DESIGNER: ARCHITECT

CONTRACT NO: 1052

DATE OF ISSUE: 10/10/2023

PROJECT LOCATION: 1052

CLIENT: MR. SURESH KUMAR

DESIGNER: ARCHITECT

CONTRACT NO: 1052

DATE OF ISSUE: 10/10/2023

PROJECT LOCATION: 1052

CLIENT: MR. SURESH KUMAR

DESIGNER: ARCHITECT