

SITE PLAN

FAR & Tenement Details (Table 4c-1)

Building	No. of Same Bldg	Gross Built Up Area (Sq.mt.)	Deductions From Gross BUA/Area in Sq.mt. Cutout	Total Built Up Area (Sq.mt.)	Proposed FAR Area (Sq.mt.)	Total FAR Area (Sq.mt.)	Total Consumed Additional FAR Area (Sq.mt.)	Tnmt (No.)
1052 (SURESH KUMAR)	1	256.34	12.28	244.06	244.06	244.06	244.06	02
Grand Total :	1	256.34	12.28	244.06	244.06	244.06	244.06	02

Proposal Basic Information

Proposal File No.	JNP/BP/0093/W19/2022
Owner Name	suresh kumar
Khata No	33
Plot No	1052
Village Name	Gomo
Use	Commercial
SubUse	Shop

Required Parking (Table 7a)

Building Name	Type	SubUse	Area (Sq.mt.)	Units		Car		TwoWheeler			
				Reqd.	Prop.	Reqd./Unit	Reqd.	Prop.	Reqd./Unit	Reqd.	Prop.
1052 (SURESH KUMAR)	Commercial	Shop	> 0	50	219.30	1	3	-	-	-	-
Total :	-	-	-	50	219.30	-	-	-	1	10	-

Parking Check (Table 7b)

Vehicle Type	Reqd.		Prop.	
	No.	Area	No.	Area
Car	-	-	4	50.00
Total Car	3	37.50	4	50.00
TwoWheeler	-	-	13	26.00
Total TwoWheeler	10	20.00	13	26.00
Total		57.50		102.00

AREA STATEMENT	VERSION NO. : 1.0.64
JHUMRITILAIYA NAGAR PARISHAD	VERSION DATE: 16/10/2020
PROJECT DETAIL:	
Region: JHARKHAND URBAN LOCAL BODIES	Plot Use: Commercial
District: KODERMA	Plot SubUse: Shop
Authority: JHUMRITILAIYA NAGAR PARISHAD	PlotNearby/ReligiousStructure: NA
Inward No: JNP/BP/0093/W19/2022	PlotSubPlot No: 1052
Application Type: General Proposal	North: Plot No. - 1052
Project Type: Building Permission	South: Plot No. - 1052
Nature of Development: New	East: Road Width - 45
Location of Development Area: Old Area	West: Plot No. - 1052
AREA DETAILS:	SQ.MT.
AREA OF PLOT (Minimum)	(A) 350.76
NET AREA OF PLOT(Gross Plot Area - Deduction from Gross Plot area)	(A-Deductions) 350.76
Deduction for Balance Plot Area(from Gross Plot Area)	
Common Plot	23.29
Total	23.29
BALANCE AREA OF PLOT(Net Plot Area - Recreational/Amenity space)	(A-Deductions) 327.47
PLOT AREA FOR COVERAGE(Net Plot Area)	(A-Deductions) 350.76
Plot Area for FAR (Net Plot Area + RoadWidening Area)	(A-Deductions) 350.76
COVERAGE CHECK	
Permissible Coverage area (50.00 %)	175.38
Proposed Coverage Area (34.79 %)	122.03
Total Prop. Coverage Area (34.79 %)	122.03
Balance coverage area (15.21 %)	53.35
FAR CHECK	
Perm. FAR Area (2.00)	701.52
Incentive FAR Area (2.000)	701.52
Perm. FAR Area (4.000)	1403.04
Total Perm. FAR area	1403.04
Commercial FAR	244.06
Proposed FAR Area	244.06
Total Proposed FAR Area	244.06
Consumed FAR (Factor)	0.70
Balance FAR Area	1158.98
BUILT UP AREA CHECK	
Total Proposed BuiltUp Area	244.06
ARCHITECT (Regd)	BIJOY KUMAR SINGH
ENGINEER (Regd)	
SUPERVISOR (Regd)	
OWNER (Regd)	suresh kumar
DEVELOPMENT AUTHORITY	LOCAL BODY

COLOR INDEX	
PLOT BOUNDARY	Black
ABUTTING ROAD	Green
PROPOSED CONSTRUCTION	Red
COMMON PLOT	Yellow
ROAD WIDENING AREA	Blue
EXISTING (To be retained)	Blue
EXISTING (To be demolished)	Yellow

Buildingwise Floor FAR Details

Floor Name	Building Name		Total	
	1052 (SURESH KUMAR)		Total Proposed Built Up Area (Sq.mt.)	Total FAR Area (Sq.mt.)
Ground Floor	122.03	122.03	122.03	122.03
First Floor	122.03	122.03	122.03	122.03
Terrace Floor	0.00	0.00	0.00	0.00
Total :	244.06	244.06	244.06	244.06

Building USE/SUBUSE Details

Building Name	Building Use	Building SubUse	Building Structure
1052 (SURESH KUMAR)	Commercial	Shop	Non-Highrise

LTP NAME AND SIGNATURE	STRUCTURAL ENG'S NAME AND SIGNATURE	BUILDER NAME AND SIGNATURE	DIGITAL SIGNATURE
BIJOY KUMAR SINGH JNP/SUP/0005/2017			

Proposal Basic Information

Proposal File No.	JNP/BP/0093/W19/2022
Owner Name	suresh kumar
Khata No	33
Plot No	1052
Village Name	Gomo
Use	Commercial
SubUse	Shop

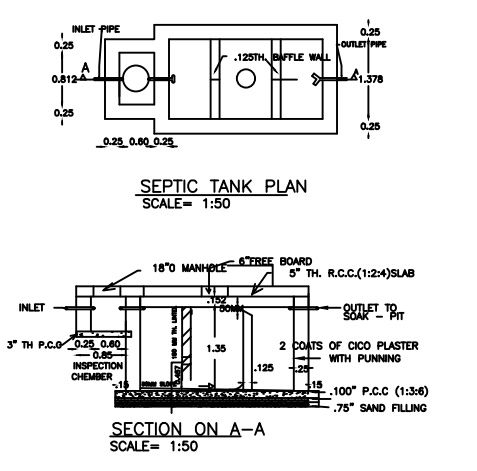
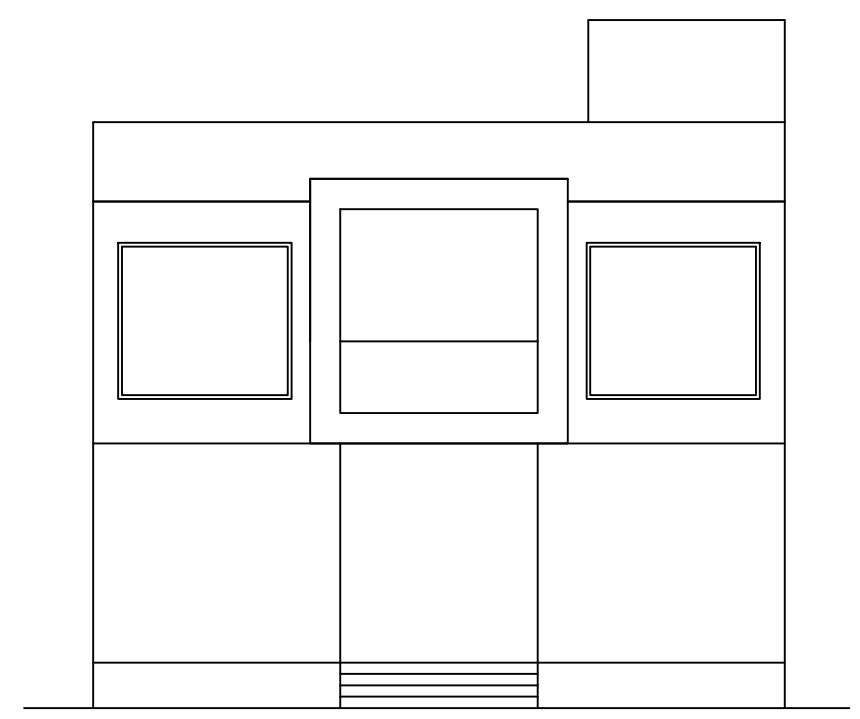
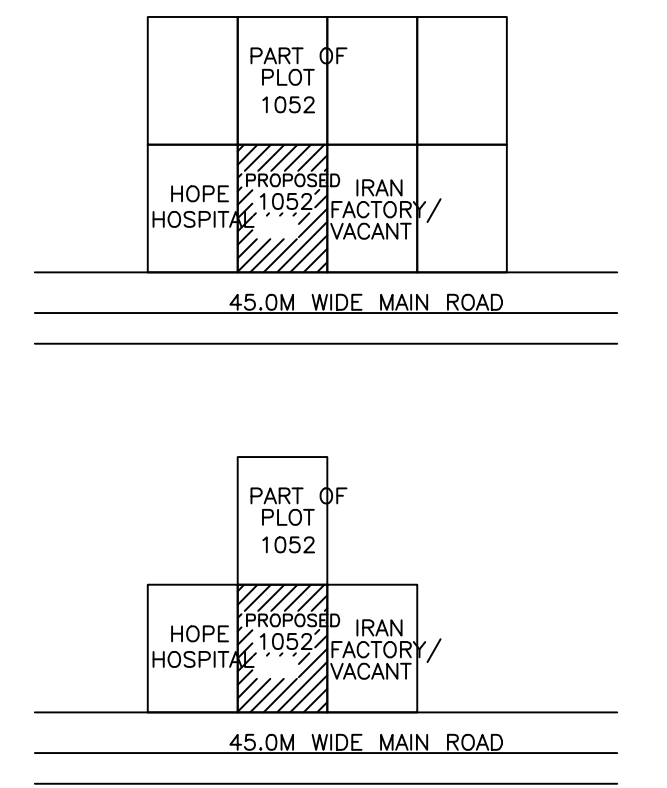
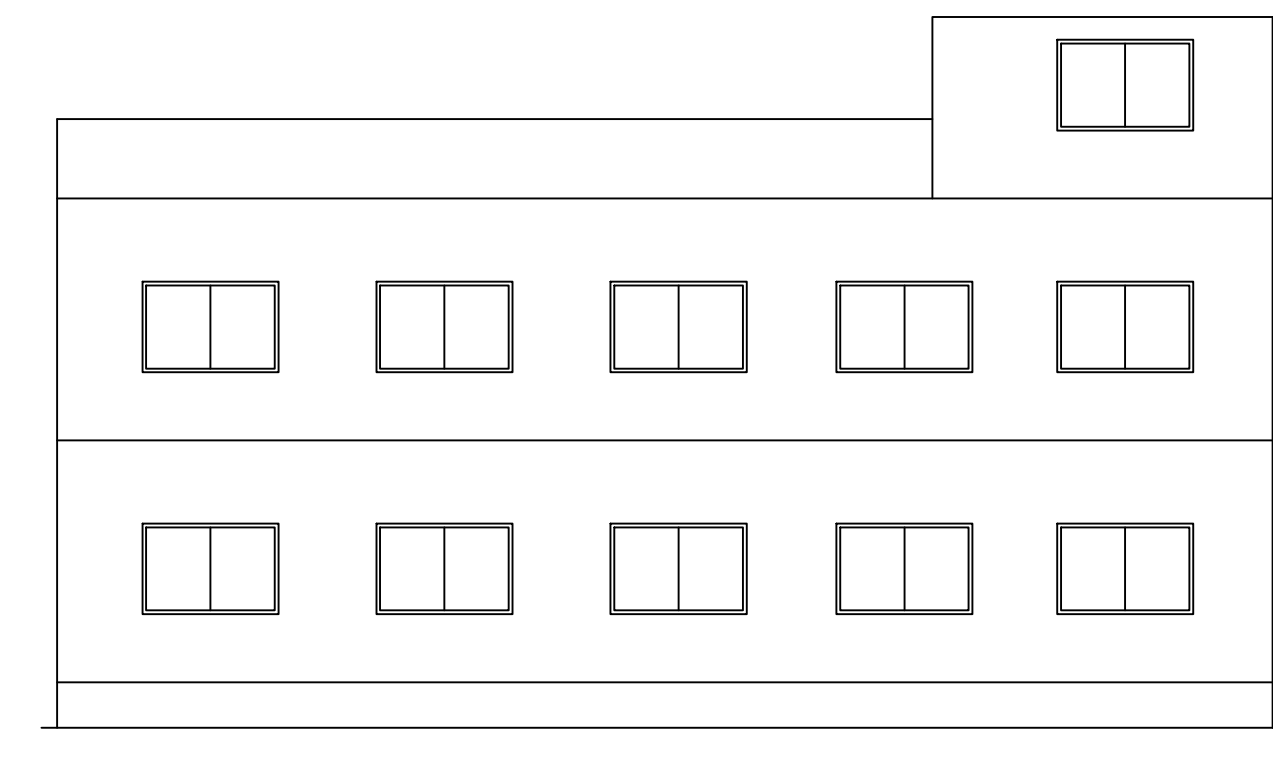
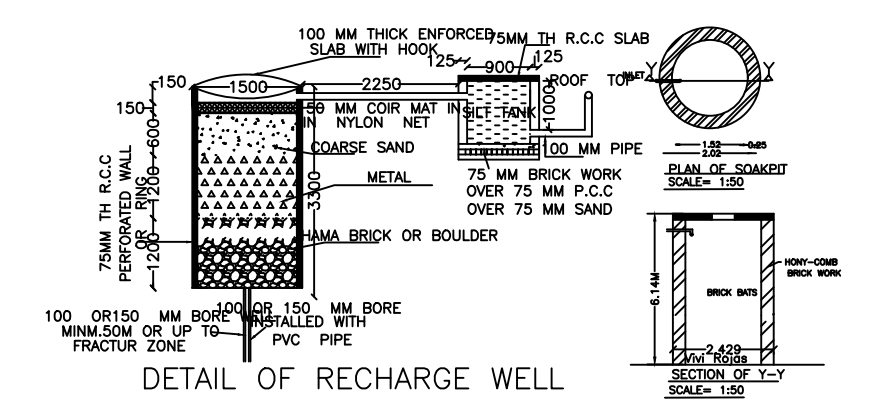
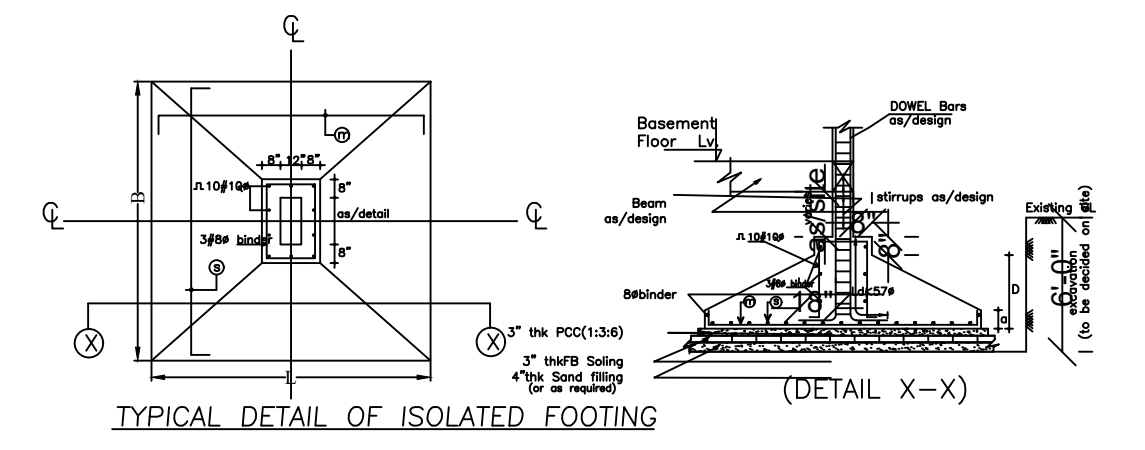
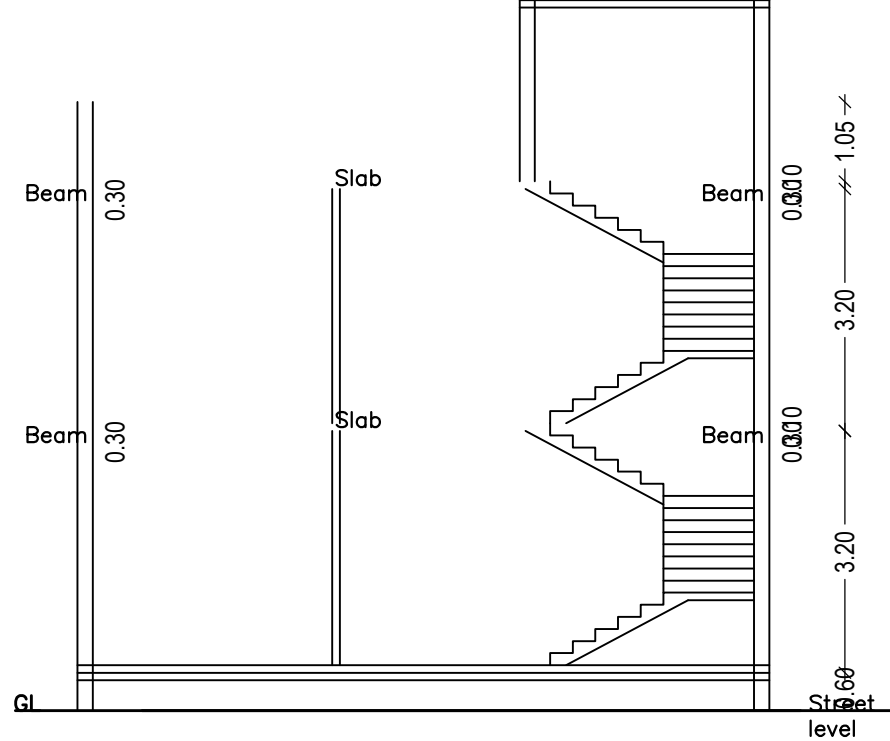
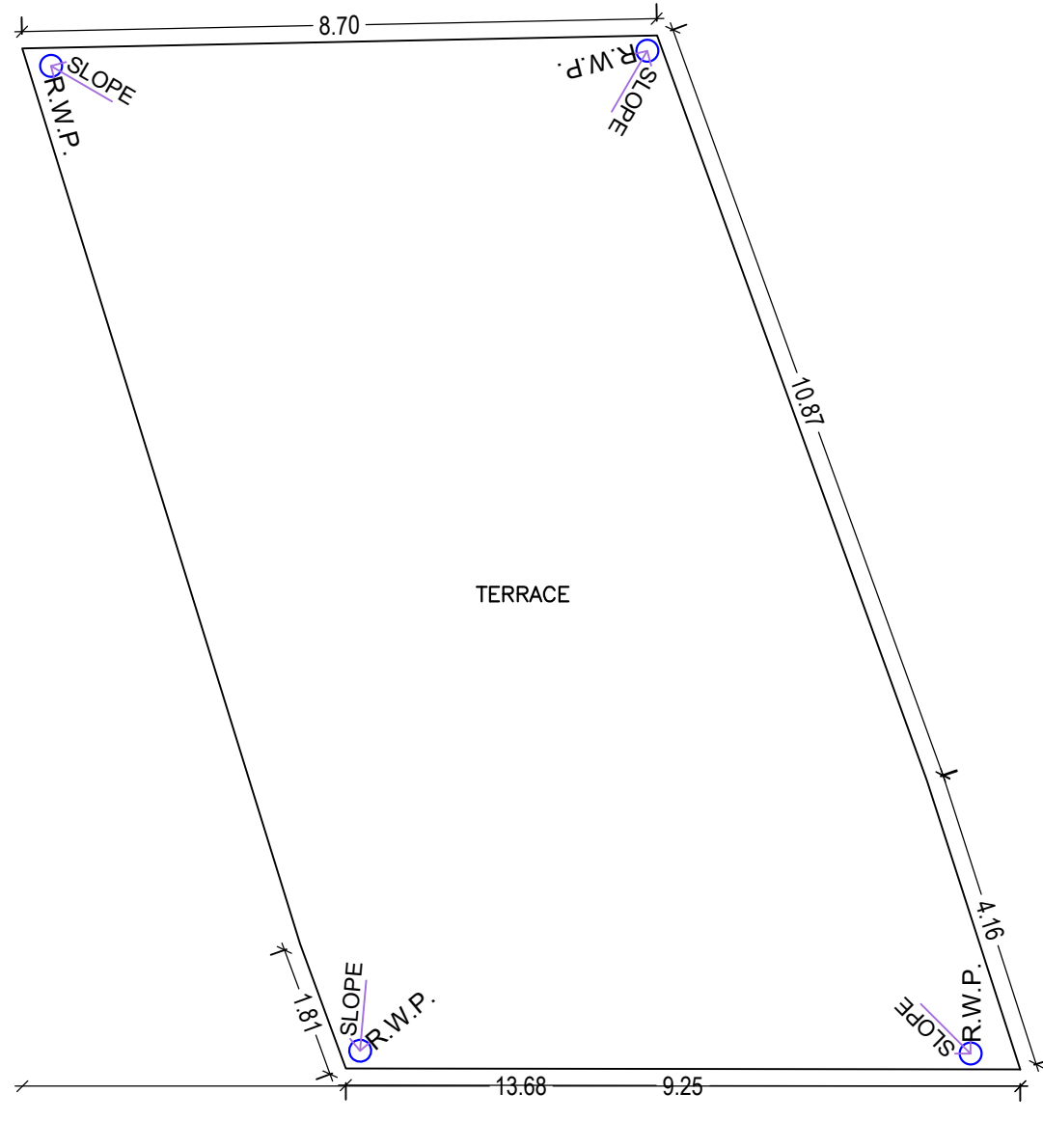

Building :1052 (SURESH KUMAR)

Floor Name	Gross Builtup Area	Deductions From Gross BUA/Area in Sq.mt.)	Total Built Up Area (Sq.mt.)	Proposed FAR Area (Sq.mt.)	Total FAR Area (Sq.mt.)	Total Consumed Additional FAR Area (Sq.mt.)	Tnmt (No.)
Ground Floor	128.17	6.14	122.03	122.03	122.03	122.03	01
First Floor	128.17	6.14	122.03	122.03	122.03	122.03	01
Terrace Floor	0.00	0.00	0.00	0.00	0.00	0.00	00
Total :	256.34	12.28	244.06	244.06	244.06	244.06	02
Total Number of Same Buildings	1						
Total :	256.34	12.28	244.06	244.06	244.06	244.06	02

SCHEDULE OF DOOR:

BUILDING NAME	NAME	LENGTH	HEIGHT	NOS
1052 (SURESH KUMAR)	D1	0.90	2.10	02
1052 (SURESH KUMAR)	R/S	2.40	2.10	12

SCHEDULE OF WINDOW/VENTILATION:

BUILDING NAME	NAME	LENGTH	HEIGHT	NOS
1052 (SURESH KUMAR)	V	1.20	0.60	02
1052 (SURESH KUMAR)	W1	1.20	1.50	04
1052 (SURESH KUMAR)	W	1.80	1.20	14

UnitBUA Table for Building :1052 (SURESH KUMAR)

FLOOR	Name	UnitBUA Type	UnitBUA Area	Carpet Area	No. of Rooms	No. of Tenement
GROUND FLOOR PLAN	SHOP	OTHER	122.03	120.45	6	1
FIRST FLOOR PLAN	SHOP	OTHER	122.03	120.45	6	1
Total:	-	-	244.06	240.90	12	2

LTP NAME AND SIGNATURE	STRUCTURAL ENG'S NAME AND SIGNATURE	BUILDER NAME AND SIGNATURE	DIGITAL SIGNATURE
BIJOY KUMAR SINGH JNP/SUP/0005/2017			