

SITE PLAN

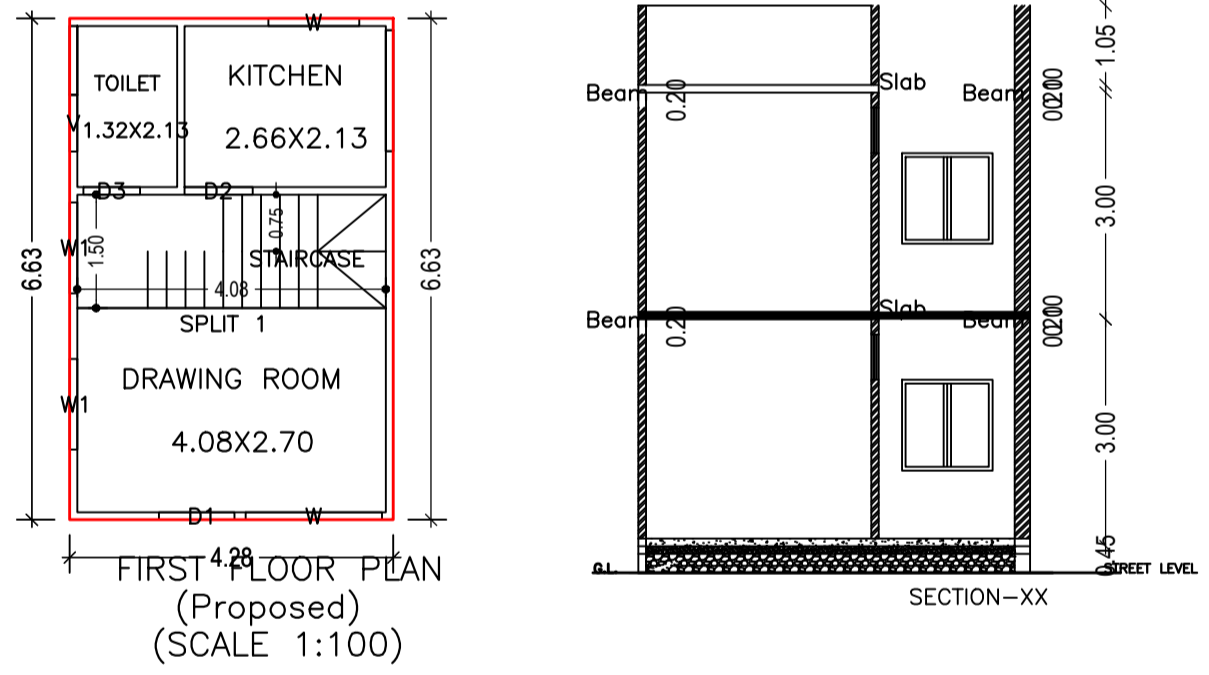
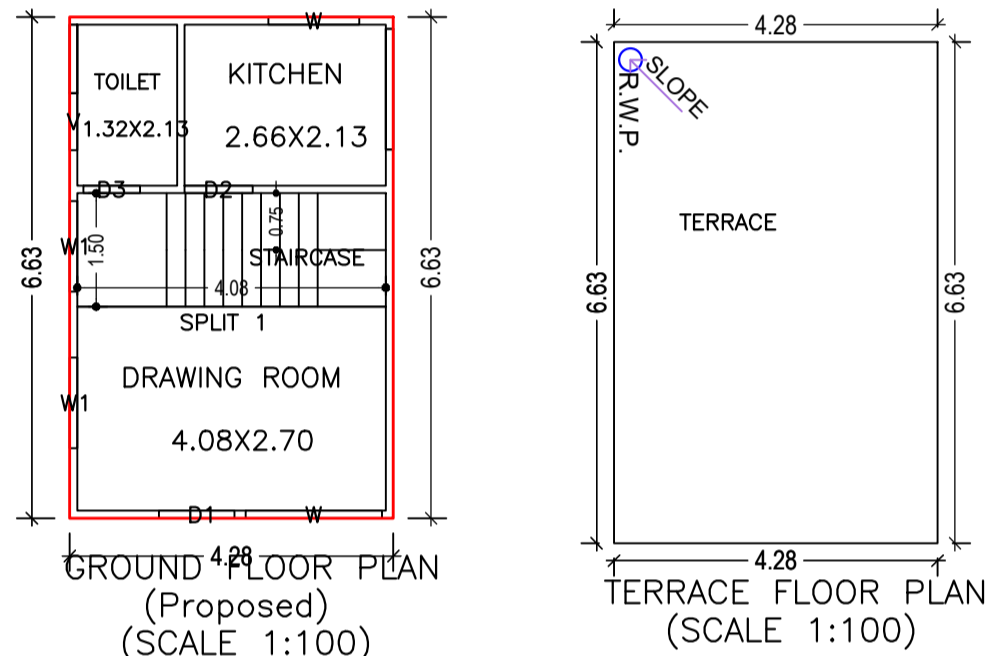

SCHEDULE OF DOOR:

BUILDING NAME	NAME	LENGTH	HEIGHT	NOS
7160 (RANI RAJGARHIA)	D3	0.75	2.10	02
7160 (RANI RAJGARHIA)	D2	0.90	2.10	02
7160 (RANI RAJGARHIA)	D1	1.00	2.10	02

SCHEDULE OF WINDOW/VENTILATION:

BUILDING NAME	NAME	LENGTH	HEIGHT	NOS
7160 (RANI RAJGARHIA)	V	0.75	0.75	02
7160 (RANI RAJGARHIA)	W	1.20	1.20	02
7160 (RANI RAJGARHIA)	W1	1.20	1.20	04
7160 (RANI RAJGARHIA)	W	1.80	1.20	02

UnitBUA Table for Building :7160 (RANI RAJGARHIA)

FLOOR	Name	UnitBUA Type	UnitBUA Area	Carpet Area	No. of Rooms	No. of Tenement
GROUND FLOOR PLAN	SPLIT 1	FLAT	56.75	56.25	3	1
FIRST FLOOR PLAN	SPLIT 1	FLAT	0.00	0.00	3	0
Total:	-	-	56.75	56.25	6	1

Building :7160 (RANI RAJGARHIA)

Floor Name	Total Built Up Area (Sq.mt.)	Proposed FAR Area (Sq.mt.) Resi.	Total FAR Area (Sq.mt.)	Total Consumed Additional FAR Area (Sq.mt.)	Tnmt (No.)
Ground Floor	28.38	28.38	28.38	28.38	01
First Floor	28.38	28.38	28.38	28.38	00
Terrace Floor	0.00	0.00	0.00	0.00	00
Total:	56.76	56.76	56.76	56.76	01
Total Number of Same Buildings	1				
Total:	56.76	56.76	56.76	56.76	01

FAR & Tenement Details (Table 4c-1)

Building	No. of Same Bldg	Total Built Up Area (Sq.mt.)	Proposed FAR Area (Sq.mt.) Resi.	Total FAR Area (Sq.mt.)	Total Consumed Additional FAR Area (Sq.mt.)	Tnmt (No.)
7160 (RANI RAJGARHIA)	1	56.76	56.76	56.76	56.76	01
Grand Total :	1	56.76	56.76	56.76	56.76	01

Proposal Basic Information

Proposal File No.	JNP/IBP/0052/W14/2022
Owner Name	Rani Rajgarhia
Khata No	381
Plot No	7160
Village Name	Tilaiya
Use	Residential
SubUse	Bungalow/ Dwelling / Non Apartment

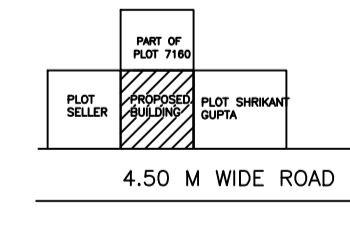
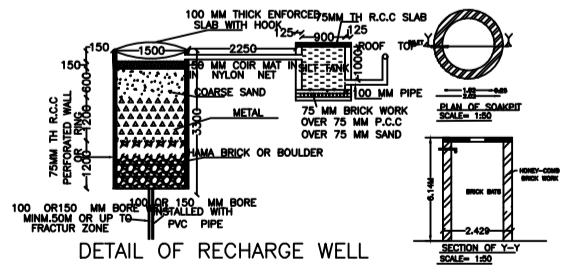
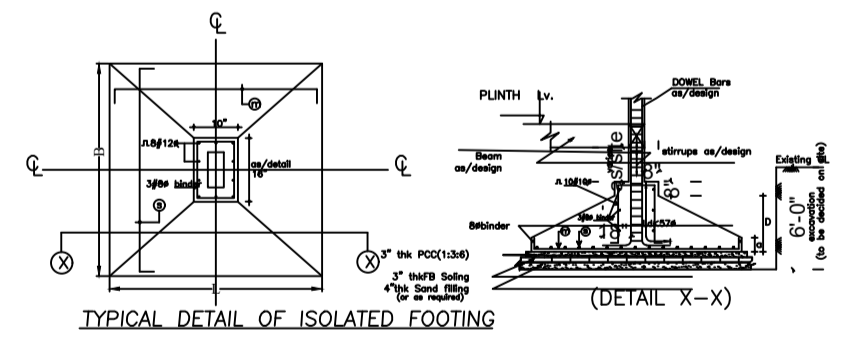
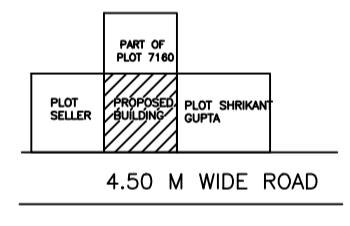
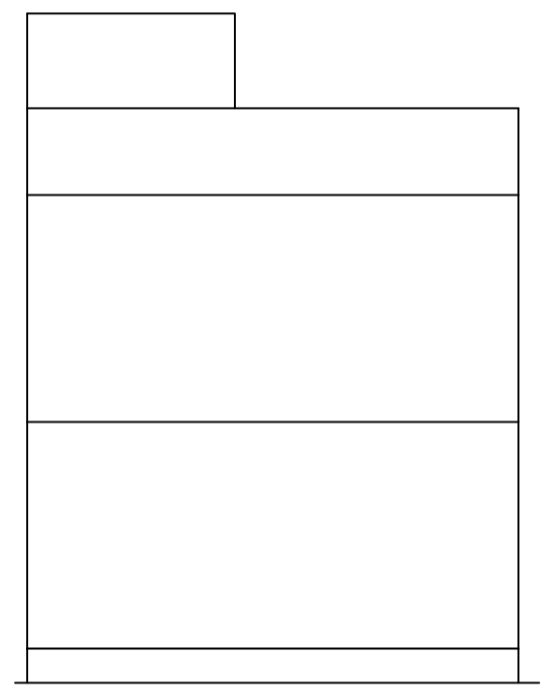
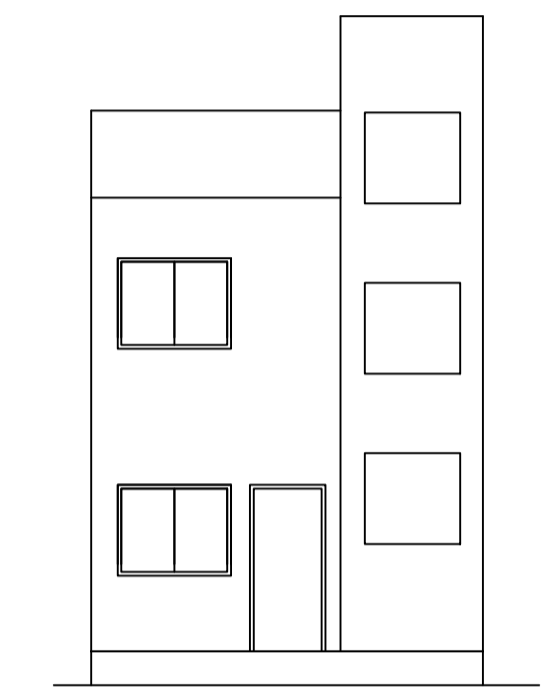
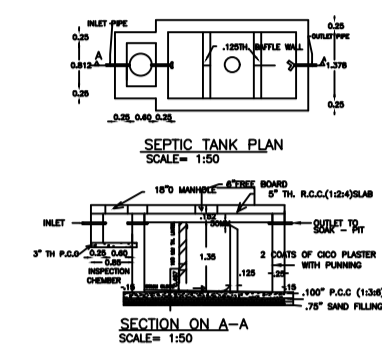

AREA STATEMENT		VERSION NO. : 1.0.65
JHUMRITILAIYA NAGAR PARISHAD		VERSION DATE: 16/10/2020
PROJECT DETAIL:		
Region: JHARKHAND URBAN LOCAL BODIES	Plot Use: Residential	
District: KODERMA	Plot SubUse: Bungalow/ Dwelling / Non Apartment	
Authority: JHUMRITILAIYA NAGAR PARISHAD	PlotNearbyReligiousStructure: NA	
Inward No: JNP/IBP/0052/W14/2022	PlotSubPlot No: 7160	
Application Type: General Proposal	North: Plot No. - 7160	
Project Type: Building Permission	South: Plot No. - 7160	
Nature of Development: New	East: Road Width - 4.57	
Location of Development Area: Old Area	West: Plot No. - 7160	
AREA DETAILS:		
AREA OF PLOT (Minimum)	(A)	SQ.MT. 47.29
NET AREA OF PLOT(Gross Plot Area - Deduction from Gross Plot area)	(A-Deductions)	47.29
Deduction for Balance Plot Area(from Gross Plot Area)		
Common Plot		5.83
BALANCE AREA OF PLOT(Net Plot Area - Recreational/Amenity space)	(A-Deductions)	41.46
PLOT AREA FOR COVERAGE(Net Plot Area)	(A-Deductions)	47.29
Plot Area for FAR (Net Plot Area + RoadWidening Area)	(A-Deductions)	47.29
COVERAGE CHECK		
Permissible Coverage area (70.00 %)		33.10
Proposed Coverage Area (60.01 %)		28.38
Total Prop. Coverage Area (60.01 %)		28.38
Balance coverage area (9.98 %)		4.72
FAR CHECK		
Perm. FAR Area (1.500)		70.93
Total Perm. FAR area		70.93
Residential FAR		56.75
Proposed FAR Area		56.75
Total Proposed FAR Area		56.75
Consumed FAR (Factor)		1.20
Balance FAR Area		14.18
BUILT UP AREA CHECK		
Total Proposed BuiltUp Area		56.76
ARCHITECT (Regd)	BIJOY KUMAR SINGH	
ENGINEER (Regd)		
SUPERVISOR (Regd)		
OWNER (Regd)	Rani Rajgarhia	
DEVELOPMENT AUTHORITY		LOCAL BODY

COLOR INDEX	
PLOT BOUNDARY	Black
ABUTTING ROAD	Green
PROPOSED CONSTRUCTION	Red
COMMON PLOT	Yellow
ROAD WIDENING AREA	Blue
EXISTING (To be retained)	Blue
EXISTING (To be demolished)	Yellow

Buildingwise Floor FAR Details

Floor Name	Building Name 7160 (RANI RAJGARHIA)		Total	
	Proposed Built Up Area (Sq.mt.)	Proposed FAR Area (Sq.mt.)	Total Proposed Built Up Area (Sq.mt.)	Total FAR Area (Sq.mt.)
Ground Floor	28.38	28.38	28.38	28.38
First Floor	28.38	28.38	28.38	28.38
Terrace Floor	0.00	0.00	0.00	0.00
Total :	56.76	56.76	56.76	56.76

Building USE/SUBUSE Details

Building Name	Building Use	Building SubUse	Building Structure
7160 (RANI RAJGARHIA)	Residential	Bungalow/ Dwelling / Non Apartment	Non-Highrise

LTP NAME AND SIGNATURE	STRUCTURAL ENG'S NAME AND SIGNATURE	BUILDER NAME AND SIGNATURE	DIGITAL SIGNATURE
BIJOY KUMAR SINGH JNP/SUP/0005/2017			