

SITE PLAN

FAR & Tenement Details (Table 4c-1)

Building	No. of Same Bldg	Total Built Up Area (Sq.mt)	Deductions (Area in Sq.mt.)	Proposed FAR Area (Sq.mt.)	Add Area in FAR (Sq.mt.)	Total FAR Area (Sq.mt.)	Total Consumed Additional FAR Area (Sq.mt.)	Tnmt (No.)
A (SMTKUMARI MANISHA)	1	370.00	83.98	277.50	8.52	286.02	286.02	03
Grand Total :	1	370.00	83.98	277.50	8.52	286.02	286.02	03

Proposal Basic Information

Proposal File No.	JNP/BI/0060/W07/2022
Owner Name	SMT KUMARI MANISHA
Khata No	01
Plot No	147
Village Name	Jhalpo
Use	Residential
SubUse	Bungalow/ Dwelling / Non Apartment

Required Parking (Table 7a)

Building Name	Type	SubUse	Area (Sq.mt.)	Units		Car		Visitors Car			
				Reqd.	Prop.	Reqd./Unit	Reqd.	Prop.	Reqd./Unit	Reqd.	Prop.
A (SMTKUMARI MANISHA)	Residential	Bungalow/ Dwelling / Non Apartment	> 0	1	3.00	1	3	-	-	-	-
			> 0	1	3.00	-	-	-	1	1	-
Total :			-	-	-	-	3	3	-	1	1

Parking Check (Table 7b)

Vehicle Type	Reqd.		Prop.	
	No.	Area	No.	Area
Car	-	-	3	37.50
Total Car	3	37.50	3	37.50
Visitor's Car Parking	-	-	1	12.50
Total Visitor Parking	1	12.50	1	12.50
Other Parking	-	-	-	58.98
Total		50.00		108.98

AREA STATEMENT	VERSION NO. : 1.0.64		
JHUMRITILAIYA NAGAR PARISHAD	VERSION DATE: 16/10/2020		
PROJECT DETAIL:			
Region: JHARKHAND URBAN LOCAL BODIES	Plot Use: Residential		
District: KODERMA	Plot SubUse: Bungalow/ Dwelling / Non Apartment		
Authority: JHUMRITILAIYA NAGAR PARISHAD	Plot/Nearby/Religious/Structure: NA		
Inward No: JNP/BI/0060/W07/2022	Plot/SubPlot No: 147		
Application Type: General Proposal	North: Plot No. - NIZ VENDOR		
Project Type: Building Permission	South: Plot No. - NIZ VENDOR		
Nature of Development: New	East: Road Width - 6.10M WIDE KATCHA ROAD		
Location of Development Area: Old Area	West: Plot No. - NIZ VENDOR		
AREA DETAILS:			
AREA OF PLOT (Minimum)	(A)	SQ.MT.	162.47
NET AREA OF PLOT (Gross Plot Area - Deduction from Gross Plot area)	(A-Deductions)		162.47
Deduction for Balance Plot Area (from Gross Plot Area)			
Common Plot			17.37
BALANCE AREA OF PLOT (Net Plot Area - Recreational/Amenity space)	(A-Deductions)		145.10
PLOT AREA FOR COVERAGE (Net Plot Area)	(A-Deductions)		162.47
Plot Area for FAR (Net Plot Area + Road Widening Area)	(A-Deductions)		162.47
COVERAGE CHECK			
Permissible Coverage area (60.00 %)			97.48
Proposed Coverage Area (56.93 %)			92.50
Total Prop. Coverage Area (56.93 %)			92.50
Balance coverage area (3.07 %)			4.98
FAR CHECK			
Perm. FAR Area (2.00)			324.94
Incentive FAR Area (2.000)			649.88
Total Perm. FAR area			277.51
Residential FAR			286.03
Proposed FAR Area			286.03
Total Proposed FAR Area			1.76
Consumed FAR (Factor)			363.85
Balance FAR Area			370.00
BUILT UP AREA CHECK			
Total Proposed BuiltUp Area			MD SHOAB ALAM
ARCHITECT (Regd)			ENGINEER (Regd)
SUPERVISOR (Regd)			SMT KUMARI MANISHA
OWNER (Regd)			DEVELOPMENT AUTHORITY
			LOCAL BODY

COLOR INDEX	
PLOT BOUNDARY	Black
ABUTTING ROAD	Green
PROPOSED CONSTRUCTION	Red
COMMON PLOT	Yellow
ROAD WIDENING AREA	Blue
EXISTING (To be retained)	Blue
EXISTING (To be demolished)	Yellow

Buildingwise Floor FAR Details

Floor Name	Building Name		Total	
	Proposed Built Up Area (Sq.mt.)	Proposed FAR Area (Sq.mt.)	Total Proposed Built Up Area (Sq.mt.)	Total FAR Area (Sq.mt.)
Ground Floor	92.50	8.52	92.50	8.52
First Floor	92.50	92.50	92.50	92.50
Second Floor	92.50	92.50	92.50	92.50
Third Floor	92.50	92.50	92.50	92.50
Terrace Floor	0.00	0.00	0.00	0.00
Total :	370.00	286.02	370.00	286.02

Building USE/SUBUSE Details

Building Name	Building Use	Building SubUse	Building Structure
A (SMTKUMARI MANISHA)	Residential	Bungalow/ Dwelling / Non Apartment	Non-Highrise

LTP NAME AND SIGNATURE	STRUCTURAL ENG'S NAME AND SIGNATURE	BUILDER NAME AND SIGNATURE	DIGITAL SIGNATURE
MD SHOAB ALAM JNP/ENG/001/2017			

Proposal Basic Information	
Proposal File No.	JNP/BP/0060/W07/2022
Owner Name	SMT KUMARI MANISHA
Khata No	01
Plot No	147
Village Name	Jhalpo
Use	Residential
SubUse	Bungalow/ Dwelling / Non Apartment

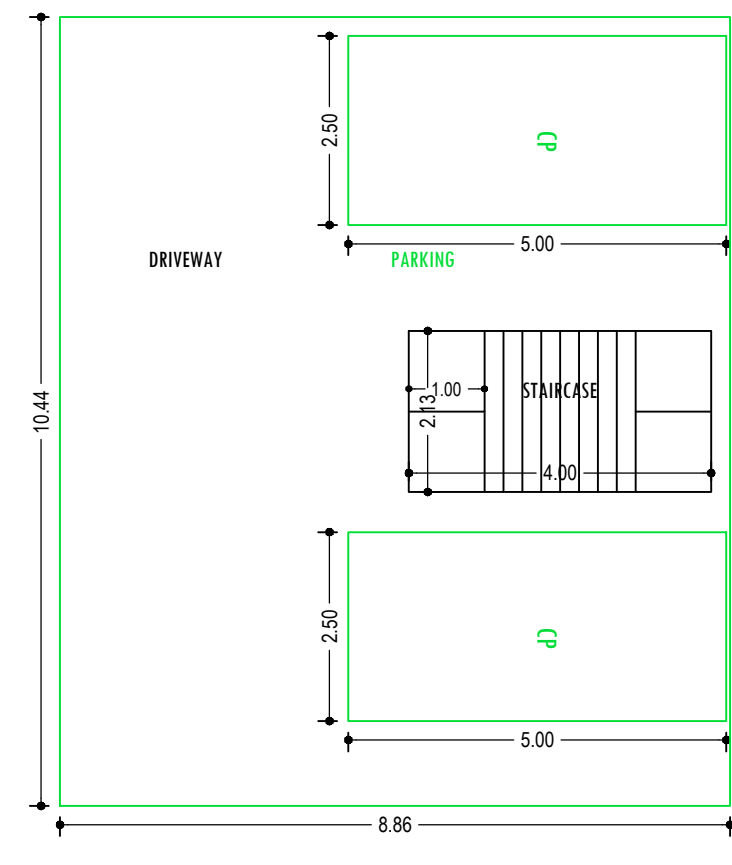

GROUND FLOOR PLAN (SCALE 1:100)

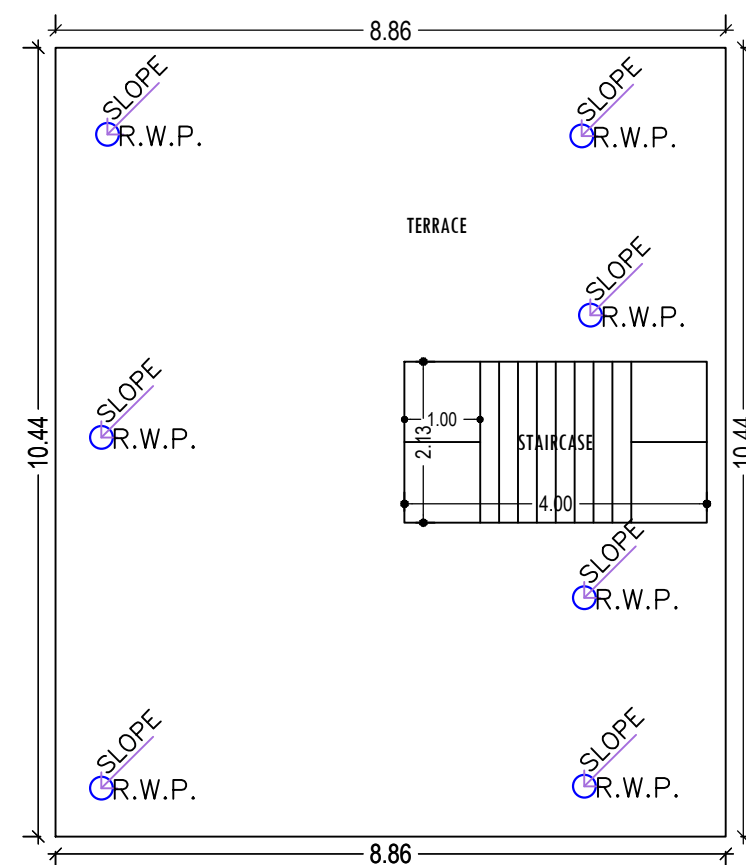

TERRACE FLOOR PLAN (SCALE 1:100)

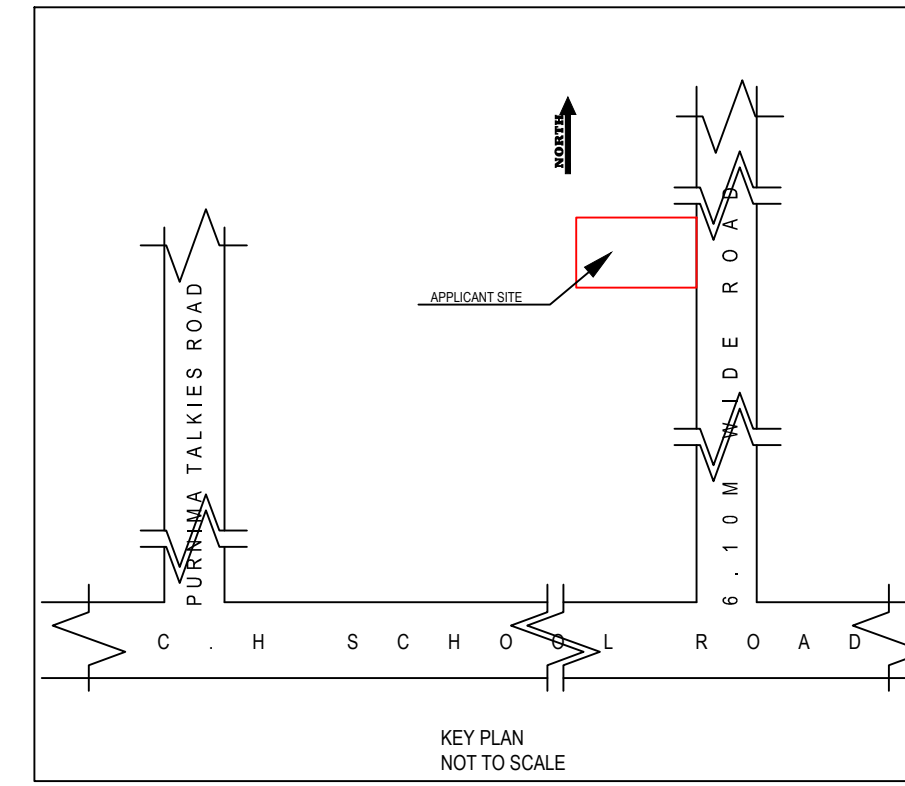

KEY PLAN NOT TO SCALE

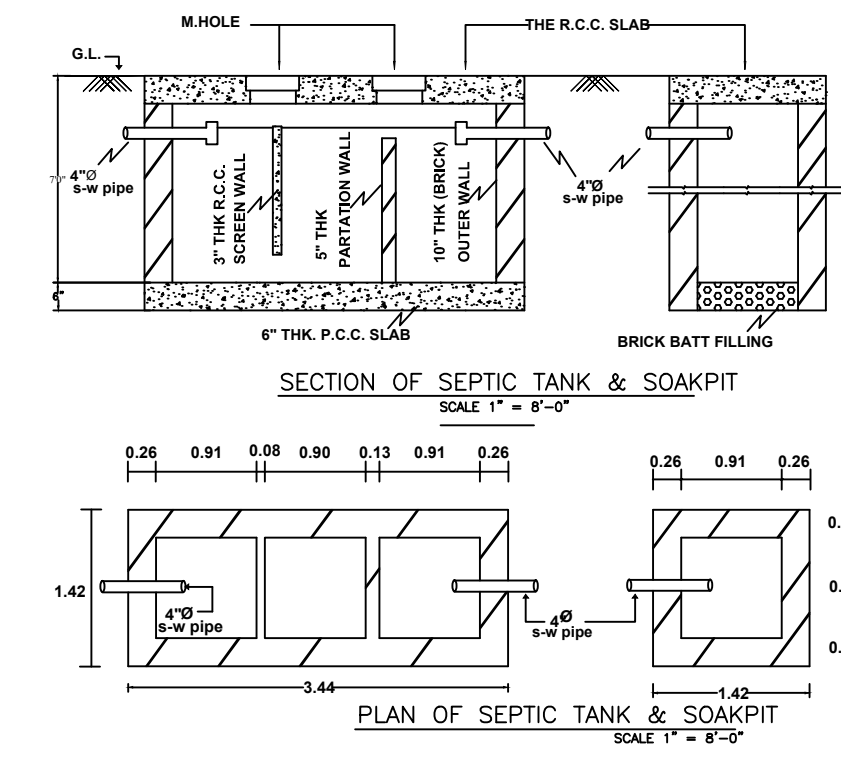

SECTION OF SEPTIC TANK & SOAKPIT SCALE 1" = 8'-0"

PLAN OF SEPTIC TANK & SOAKPIT SCALE 1" = 8'-0"



FRONT ELEVATION SCALE :- 1=100

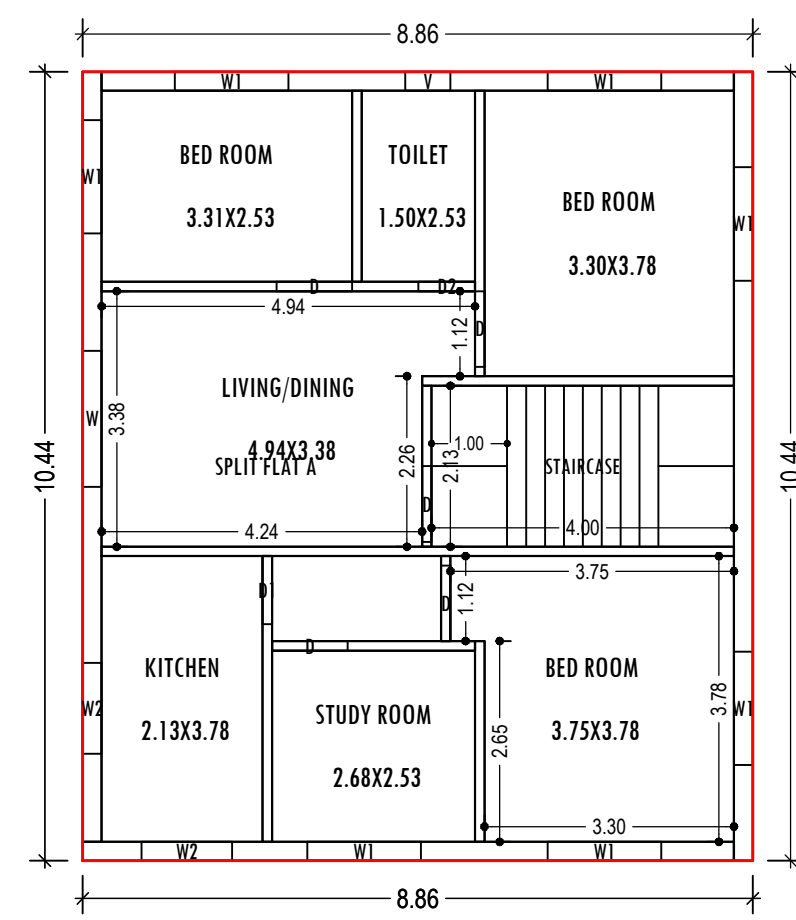

TYPICAL - 1, 2& 3 FLOOR PLAN (Proposed) (SCALE 1:100)

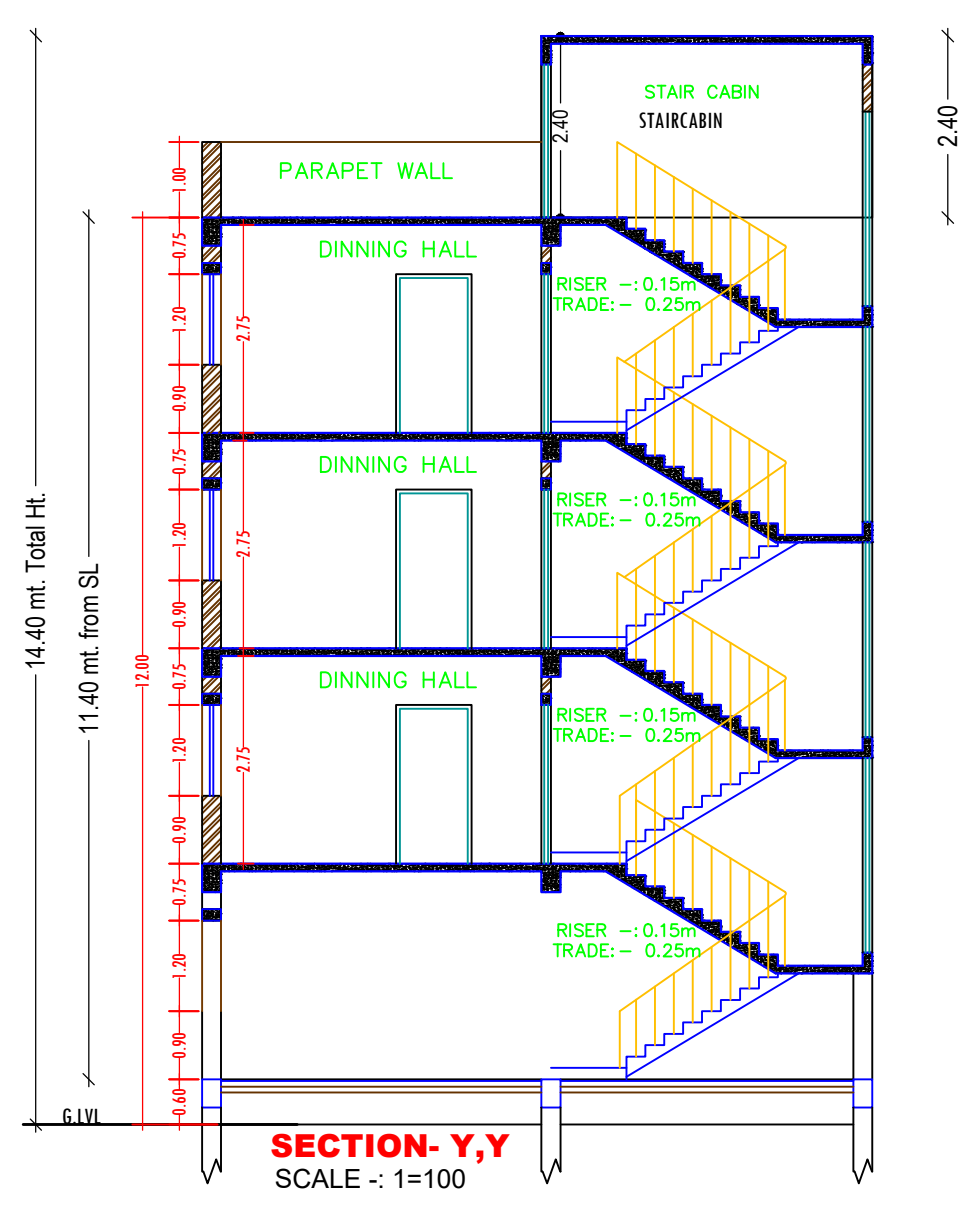

SECTION-Y,Y SCALE :- 1=100

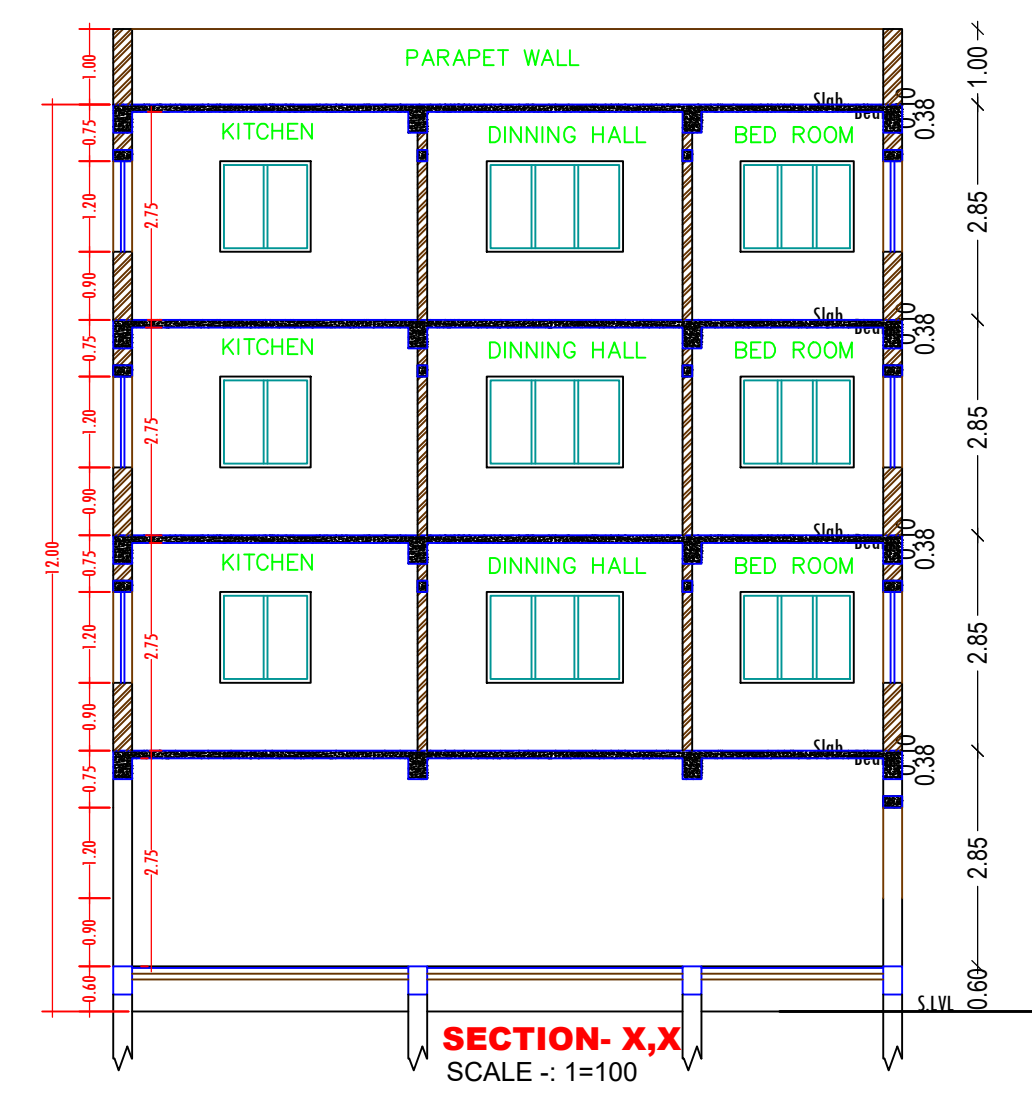

SECTION-X,X SCALE :- 1=100

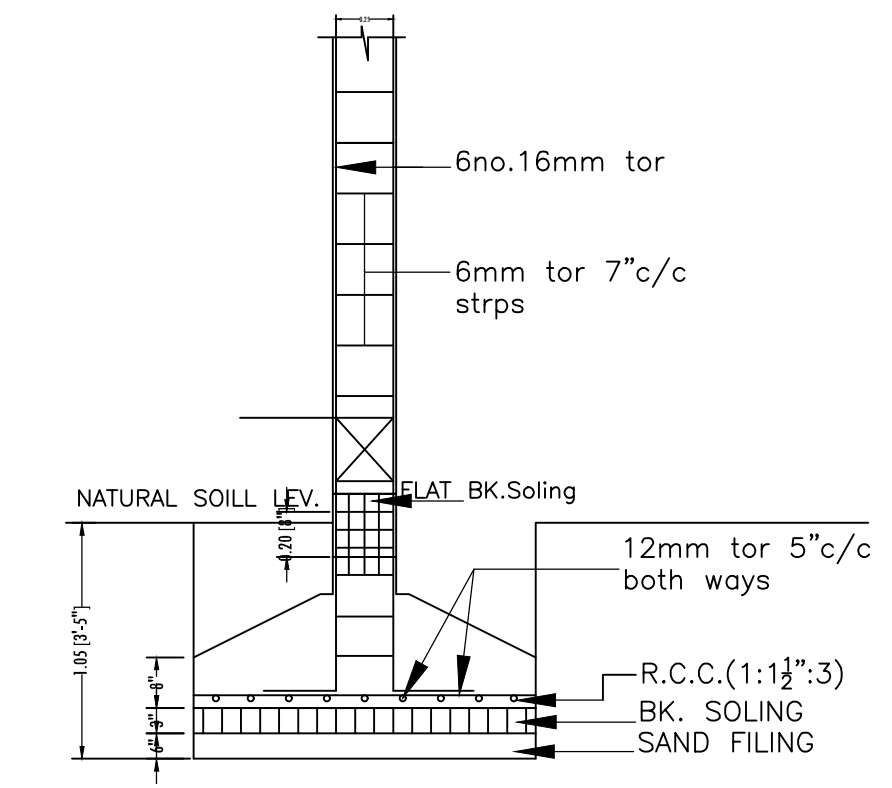

SEC. X-Y R.C.C. COLUMN FDN.DETAIL SCALE 1" = 2'-0"

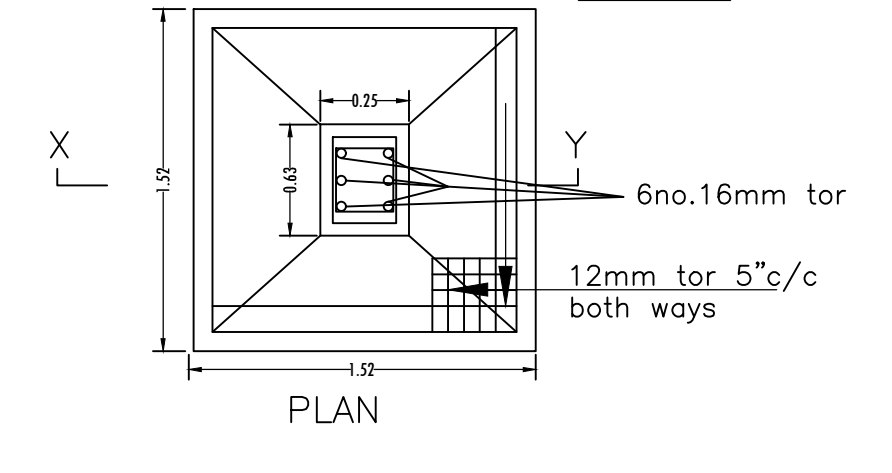

SCALE-1":2'-0"



SIDE ELEVATION SCALE :- 1=100

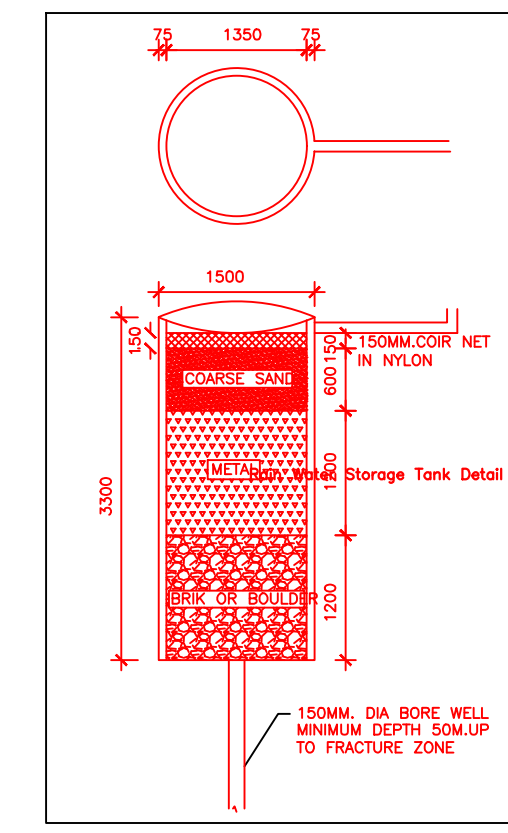

Storage Tank Detail

SCHEDULE OF DOOR:

BUILDING NAME	NAME	LENGTH	HEIGHT	NOS
A (SMTKUMARI MANISHA)	D2	0.75	2.13	03
A (SMTKUMARI MANISHA)	D1	0.90	2.13	03
A (SMTKUMARI MANISHA)	D	1.00	2.13	15

SCHEDULE OF WINDOW/VENTILATION:

BUILDING NAME	NAME	LENGTH	HEIGHT	NOS
A (SMTKUMARI MANISHA)	V	0.60	0.60	03
A (SMTKUMARI MANISHA)	W2	1.20	1.20	06
A (SMTKUMARI MANISHA)	W1	1.50	1.20	21
A (SMTKUMARI MANISHA)	W	1.80	1.20	03

UnitBUA Table for Building .A (SMTKUMARI MANISHA)

FLOOR	Name	UnitBUA Type	UnitBUA Area	Carpet Area	No. of Rooms	No. of Tenement
TYPICAL - 1, 2& 3 FLOOR PLAN	SPLIT FLAT A	FLAT	74.58	70.07	7	3
Total:	-	-	223.75	210.21	21	3

Floor Name	Total Built Up Area (Sq.mt.)	Deductions (Area in Sq.mt.)			Proposed FAR Area (Sq.mt.)	Add Area In FAR (Sq.mt.)	Total FAR Area (Sq.mt.)	Total Consumed Additional FAR Area (Sq.mt.)	Trmt (No.)
		Parking	Resi.	Stair					
Ground Floor	92.50	83.98	0.00	8.52	8.52	8.52	00		
First Floor	92.50	0.00	92.50	0.00	92.50	92.50	01		
Second Floor	92.50	0.00	92.50	0.00	92.50	92.50	01		
Third Floor	92.50	0.00	92.50	0.00	92.50	92.50	01		
Terrace Floor	0.00	0.00	0.00	0.00	0.00	0.00	00		
Total :	370.00	83.98	277.50	8.52	286.02	286.02	03		
Total Number of Same Buildings	1								
Total :	370.00	83.98	277.50	8.52	286.02	286.02	03		

LTP NAME AND SIGNATURE	STRUCTURAL ENG'S NAME AND SIGNATURE	BUILDER NAME AND SIGNATURE	DIGITAL SIGNATURE
MD SHOAIB ALAM JNP/ENG/0001/2017			