

SITE PLAN
SCALE :- 1=100

SITE PLAN

FAR & Tenement Details (Table 4c-1)

Building	No. of Same Bldg	Gross Built Up Area (Sq.mt.)	Deductions From Gross BUA/Area in Sq.mt. Cutout	Total Built Up Area (Sq.mt.)	Proposed FAR Area (Sq.mt.) Resi.	Total FAR Area (Sq.mt.)	Total Consumed Additional FAR Area (Sq.mt.)	Tnmt (No.)
AA (NARENDRA SINGH)	1	352.47	12.21	340.26	340.26	340.26	340.26	01
Grand Total :	1	352.47	12.21	340.26	340.26	340.26	340.26	01

Proposal Basic Information

Proposal File No.	JNP/IBP/0041/W12/2022
Owner Name	SRI NARENDRA SINGH
Khata No	(OLD) 292, 290 (NEW) 589
Plot No	(OLD) 3241 (NEW) 7317
Village Name	Tilaiya
Use	Residential
SubUse	Bungalow/ Dwelling / Non Apartment

AREA STATEMENT	VERSION NO. : 1.0.62
JHUMRITILAIYA NAGAR PARISHAD	VERSION DATE: 16/10/2020
PROJECT DETAIL:	
Region: JHARKHAND URBAN LOCAL BODIES	Plot Use: Residential
District: KODERMA	Plot SubUse: Bungalow/ Dwelling / Non Apartment
Authority: JHUMRITILAIYA NAGAR PARISHAD	PlotNearbyReligiousStructure: NA
Inward No: JNP/IBP/0041/W12/2022	PlotSubPlot No: (OLD) 3241 (NEW) 7317
Application Type: General Proposal	North: Plot No. - RAMLAL MUTNEJA
Project Type: Building Permission	South: Plot No. - SARDAR SOHAN SINGH
Nature of Development: New	East: Plot No. - GURJIT SINGH
Location of Development Area: Old Area	West: Road Width - 6.10M WIDE ROAD
AREA DETAILS:	
AREA OF PLOT (Minimum)	(A) 171.05
NET AREA OF PLOT(Gross Plot Area - Deduction from Gross Plot area)	(A-Deductions) 171.05
Deduction for Balance Plot Area(from Gross Plot Area)	
Common Plot	18.17
Total	18.17
BALANCE AREA OF PLOT(Net Plot Area - Recreational/Amenity space)	(A-Deductions) 152.88
PLOT AREA FOR COVERAGE(Net Plot Area)	(A-Deductions) 171.05
Plot Area for FAR (Net Plot Area + RoadWidening Area)	(A-Deductions) 171.05
COVERAGE CHECK	
Permissible Coverage area (70.00 %)	119.74
Proposed Coverage Area (66.31 %)	113.42
Total Prop. Coverage Area (66.31 %)	113.42
Balance coverage area (3.69 %)	6.32
FAR CHECK	
Perm. FAR Area (2.00)	342.10
Total Perm. FAR area	342.10
Residential FAR	340.26
Proposed FAR Area	340.26
Total Proposed FAR Area	340.26
Consumed FAR (Factor)	1.99
Balance FAR Area	1.84
BUILT UP AREA CHECK	
Total Proposed BuiltUp Area	340.26
ARCHITECT (Regd)	MD SHOAB ALAM
ENGINEER (Regd)	
SUPERVISOR (Regd)	
OWNER (Regd)	SRI NARENDRA SINGH
DEVELOPMENT AUTHORITY LOCAL BODY	

COLOR INDEX	
PLOT BOUNDARY	Black
ABUTTING ROAD	Green
PROPOSED CONSTRUCTION	Red
COMMON PLOT	Yellow
ROAD WIDENING AREA	Orange
EXISTING (To be retained)	Blue
EXISTING (To be demolished)	Light Yellow

Buildingwise Floor FAR Details

Floor Name	Building Name AA (NARENDRA SINGH)		Total	
	Proposed Built Up Area (Sq.mt.)	Proposed FAR Area (Sq.mt.)	Total Proposed Built Up Area (Sq.mt.)	Total FAR Area (Sq.mt.)
Ground Floor	113.42	113.42	113.42	113.42
First Floor	113.42	113.42	113.42	113.42
Second Floor	113.42	113.42	113.42	113.42
Terrace Floor	0.00	0.00	0.00	0.00
Total :	340.26	340.26	340.26	340.26

Building USE/SUBUSE Details

Building Name	Building Use	Building SubUse	Building Structure
AA (NARENDRA SINGH)	Residential	Bungalow/ Dwelling / Non Apartment	Non-Highrise

LTP NAME AND SIGNATURE	STRUCTURAL ENG'S NAME AND SIGNATURE	BUILDER NAME AND SIGNATURE	DIGITAL SIGNATURE
MD SHOAB ALAM JNP/ENG/001/2017			

Proposal Basic Information	
Proposal File No.	JNP/IBP/0041/W12/2022
Owner Name	SRI NARENDRA SINGH
Khata No	(OLD) 292, 290 (NEW) 589
Plot No	(OLD) 3241 (NEW) 7317
Village Name	Tilaiya
Use	Residential
SubUse	Bungalow/ Dwelling / Non Apartment

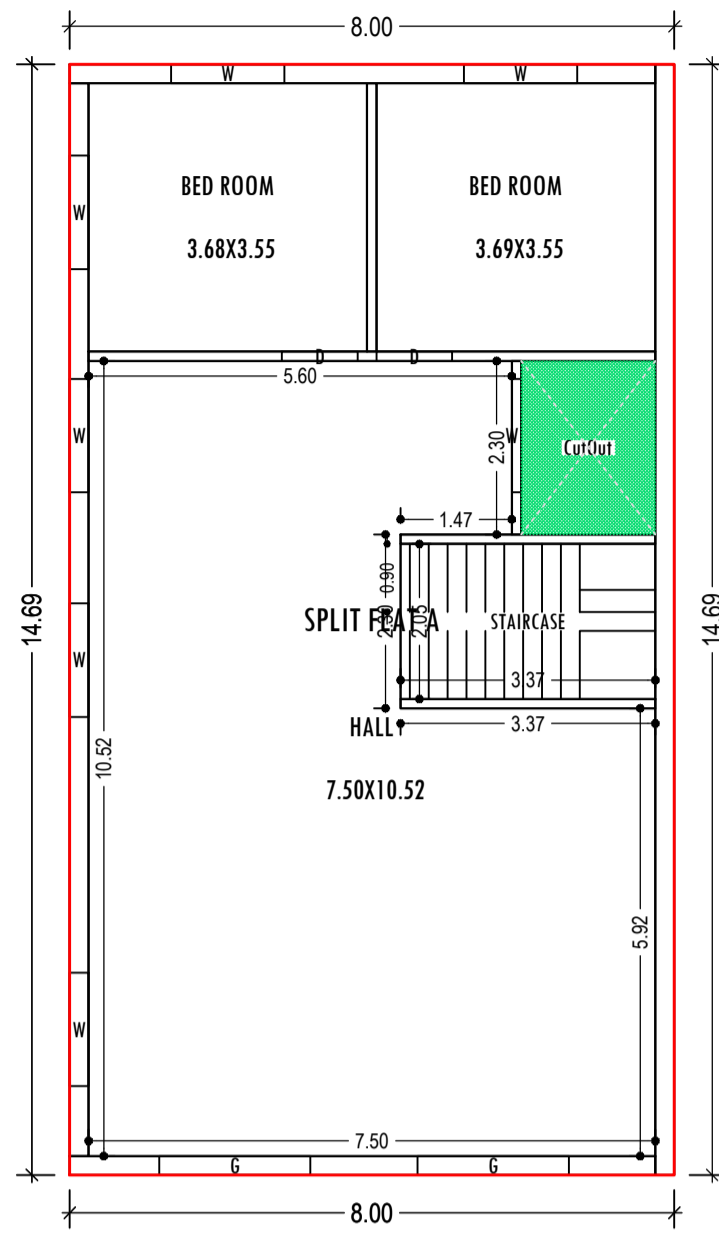

GROUND FLOOR PLAN (Proposed) (SCALE 1:100)

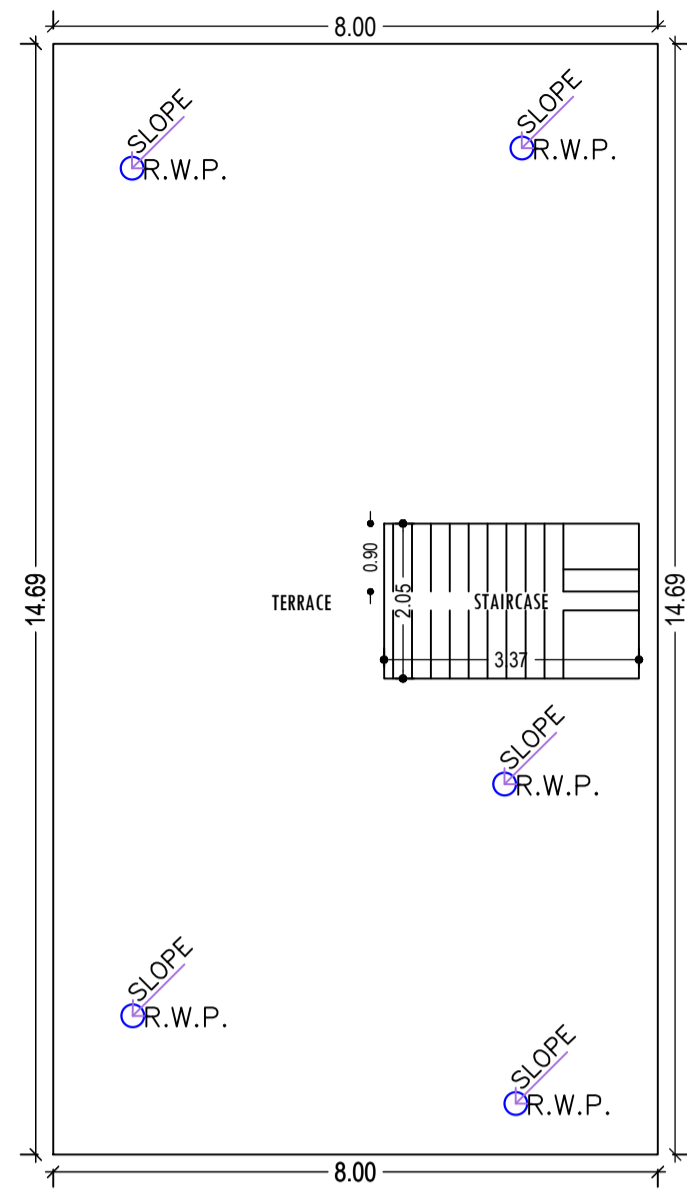

TERRACE FLOOR PLAN (SCALE 1:100)

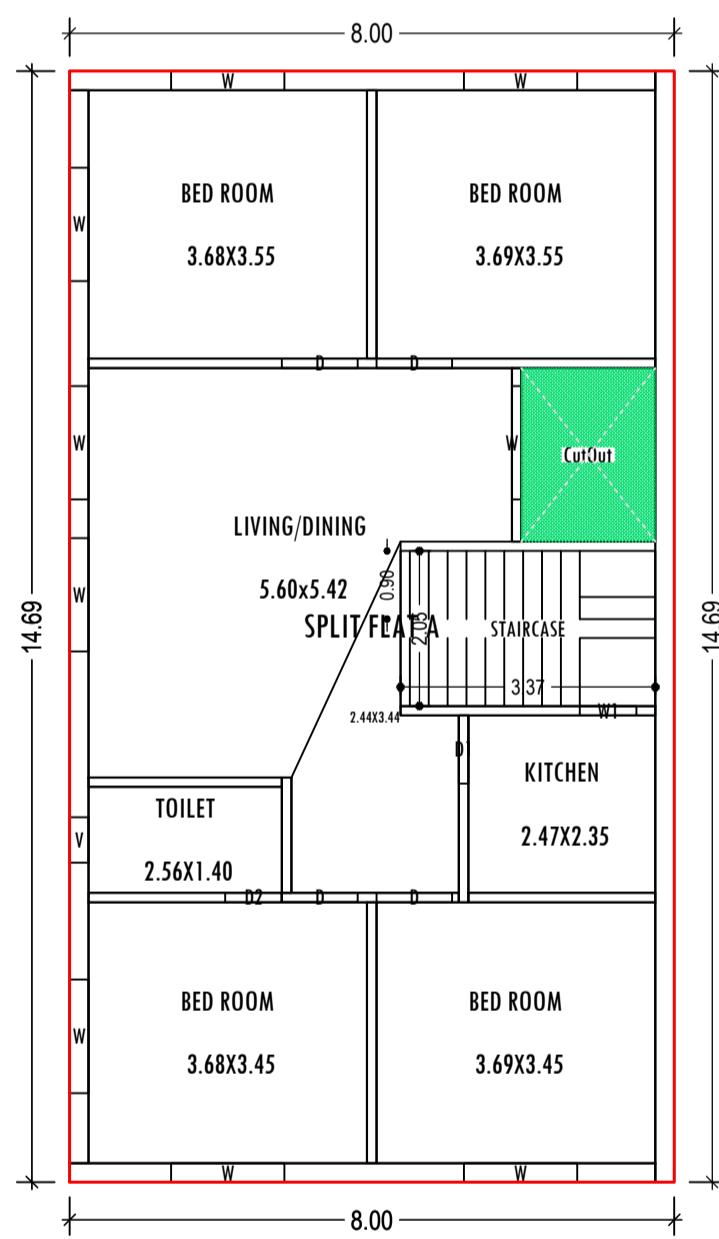

TYPICAL - 1 & 2 FLOOR PLAN (Proposed) (SCALE 1:100)

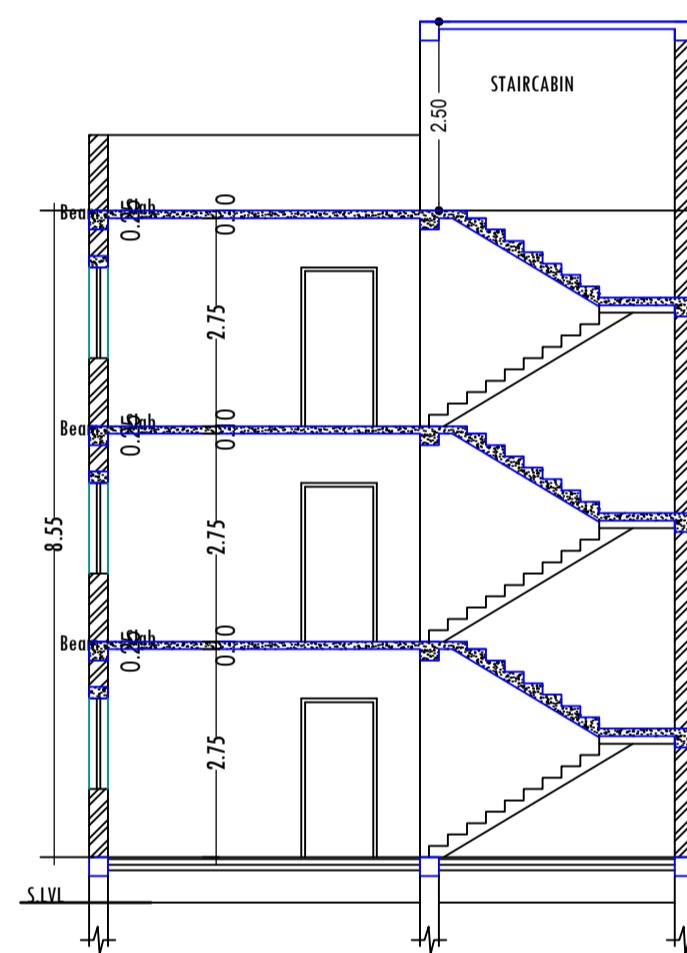

SECTION - Y-Y (SCALE 1:100)

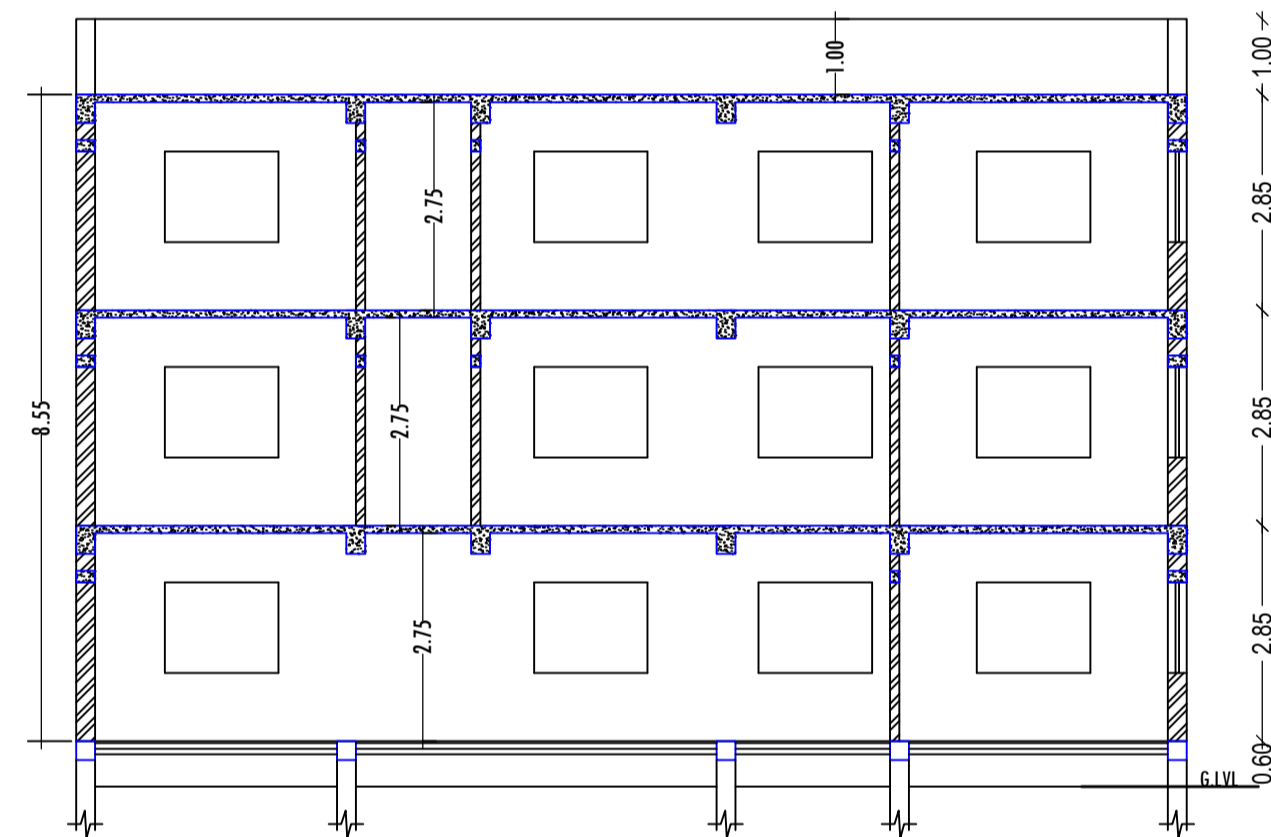

SECTION - X-X (SCALE 1:100)

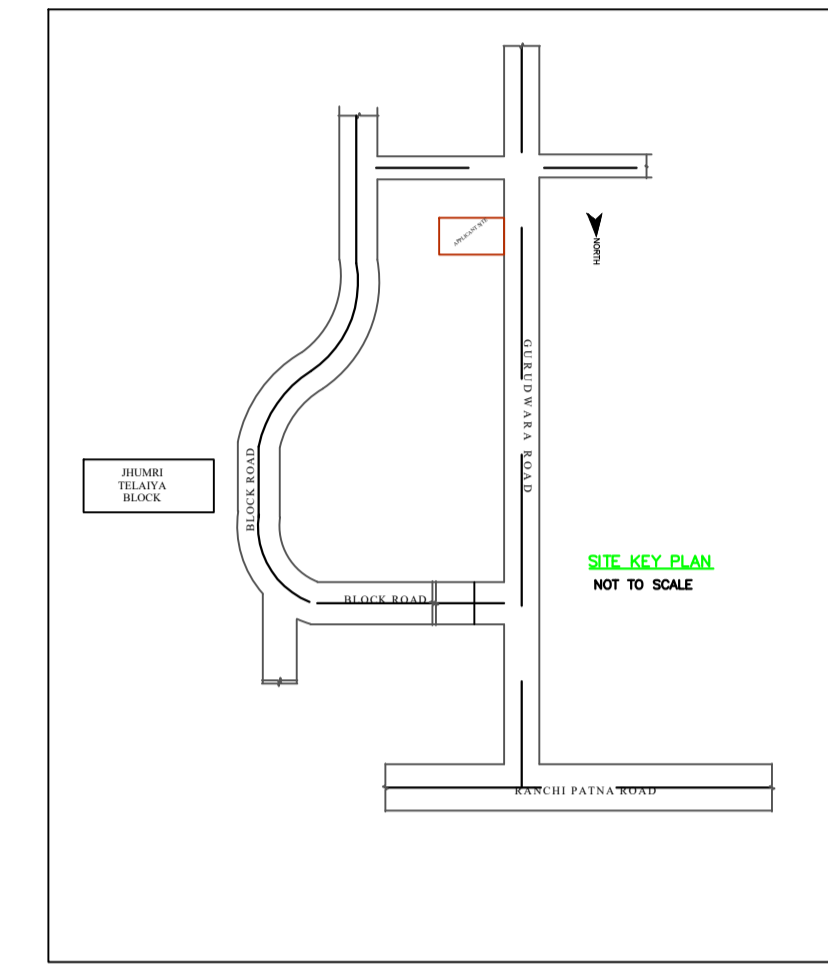

SITE KEY PLAN (NOT TO SCALE)



FRONT ELEVATION (SCALE 1:100)

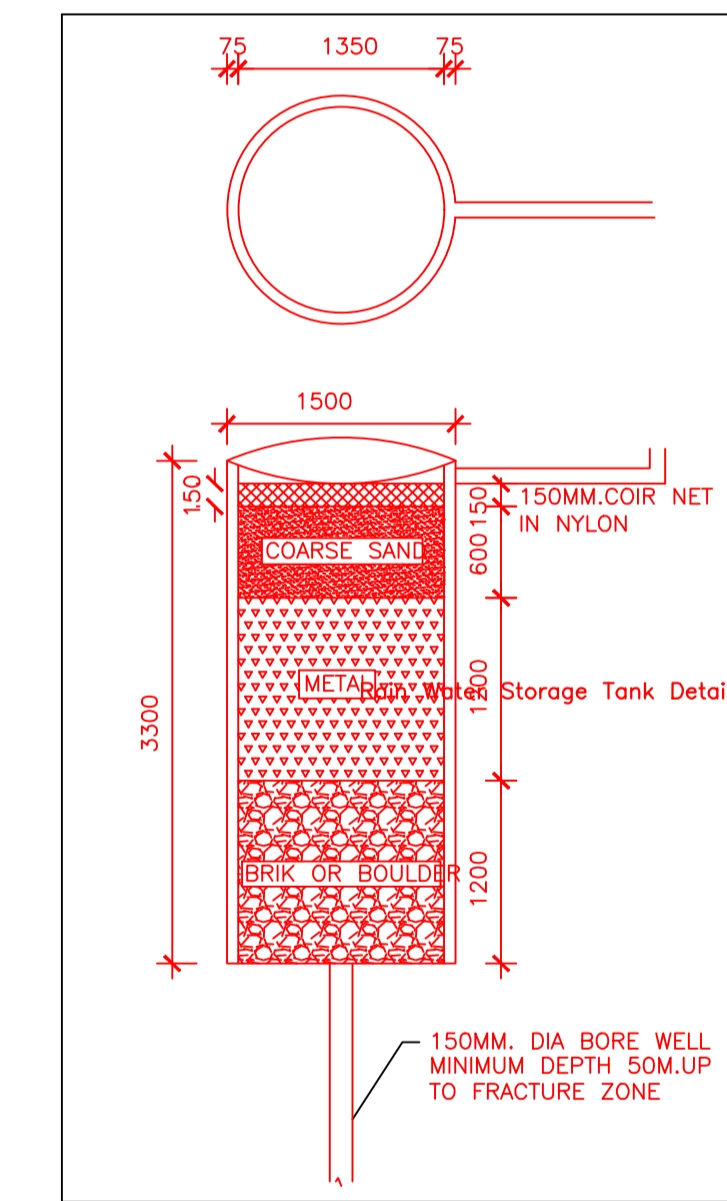

Storage Tank Detail



SIDE ELEVATION (SCALE 1:100)

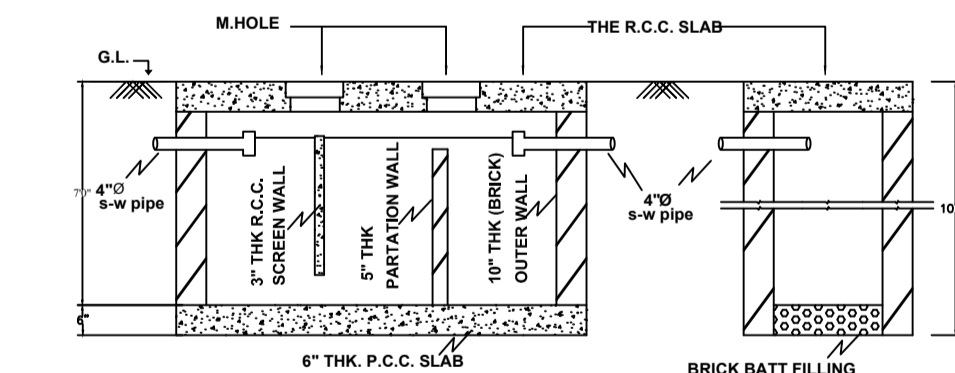

SECTION OF SEPTIC TANK & SOAKPIT (SCALE 1\"/>

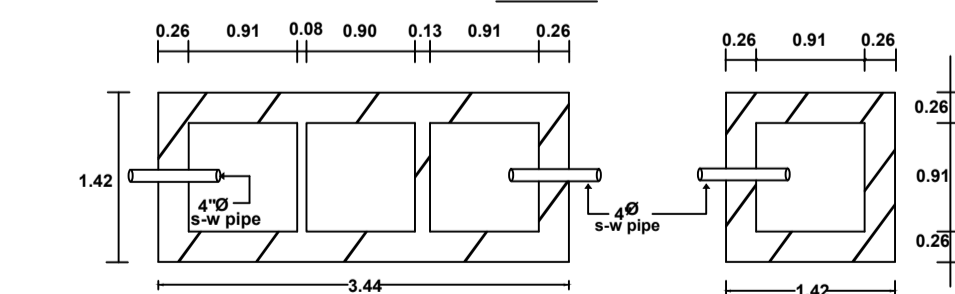

PLAN OF SEPTIC TANK & SOAKPIT (SCALE 1\"/>

SCHEDULE OF DOOR:

BUILDING NAME	NAME	LENGTH	HEIGHT	NOS
AA (NARENDRA SINGH)	D2	0.75	2.13	02
AA (NARENDRA SINGH)	D1	0.90	2.13	02
AA (NARENDRA SINGH)	D	1.00	2.13	10
AA (NARENDRA SINGH)	G	2.00	2.13	02

SCHEDULE OF WINDOW/VENTILATION:

BUILDING NAME	NAME	LENGTH	HEIGHT	NOS
AA (NARENDRA SINGH)	V	0.60	0.60	02
AA (NARENDRA SINGH)	W1	0.75	1.20	02
AA (NARENDRA SINGH)	W	1.50	1.20	25

UnitBUA Table for Building :AA (NARENDRA SINGH)

FLOOR	Name	UnitBUA Type	UnitBUA Area	Carpet Area	No. of Rooms	No. of Tenement
GROUND FLOOR PLAN	SPLIT FLAT A	FLAT	285.58	274.97	3	1
TYPICAL - 1 & 2 FLOOR PLAN	SPLIT FLAT A	FLAT	0.00	0.00	7	0
Total:	-	-	285.58	274.97	17	1

Building :AA (NARENDRA SINGH)

Floor Name	Gross Builtup Area (Sq.mt.)	Deductions From Gross BUA (Area in Sq.mt.)	Total Built Up Area (Sq.mt.)	Proposed FAR Area (Sq.mt.)	Total FAR Area (Sq.mt.)	Total Consumed Additional FAR Area (Sq.mt.)	Tnmt (No.)
Ground Floor	117.49	4.07	113.42	113.42	113.42	113.42	01
First Floor	117.49	4.07	113.42	113.42	113.42	113.42	00
Second Floor	117.49	4.07	113.42	113.42	113.42	113.42	00
Terrace Floor	0.00	0.00	0.00	0.00	0.00	0.00	00
Total :	352.47	12.21	340.26	340.26	340.26	340.26	01
Total Number of Same Buildings	1						
Total :	352.47	12.21	340.26	340.26	340.26	340.26	01

LTP NAME AND SIGNATURE	STRUCTURAL ENG'S NAME AND SIGNATURE	BUILDER NAME AND SIGNATURE	DIGITAL SIGNATURE
MD SHOAB ALAM JNP/ENG/001/2017			

Proposal Basic Information

Proposal File No.	JNP/EP/0041/W12/2022
Owner Name	SRI NARENDRA SINGH
Khata No	(OLD) 292, 290 (NEW) 589
Plot No	(OLD) 3241 (NEW) 7317
Village Name	Tilaiya
Use	Residential
SubUse	Bungalow/ Dwelling / Non Apartment

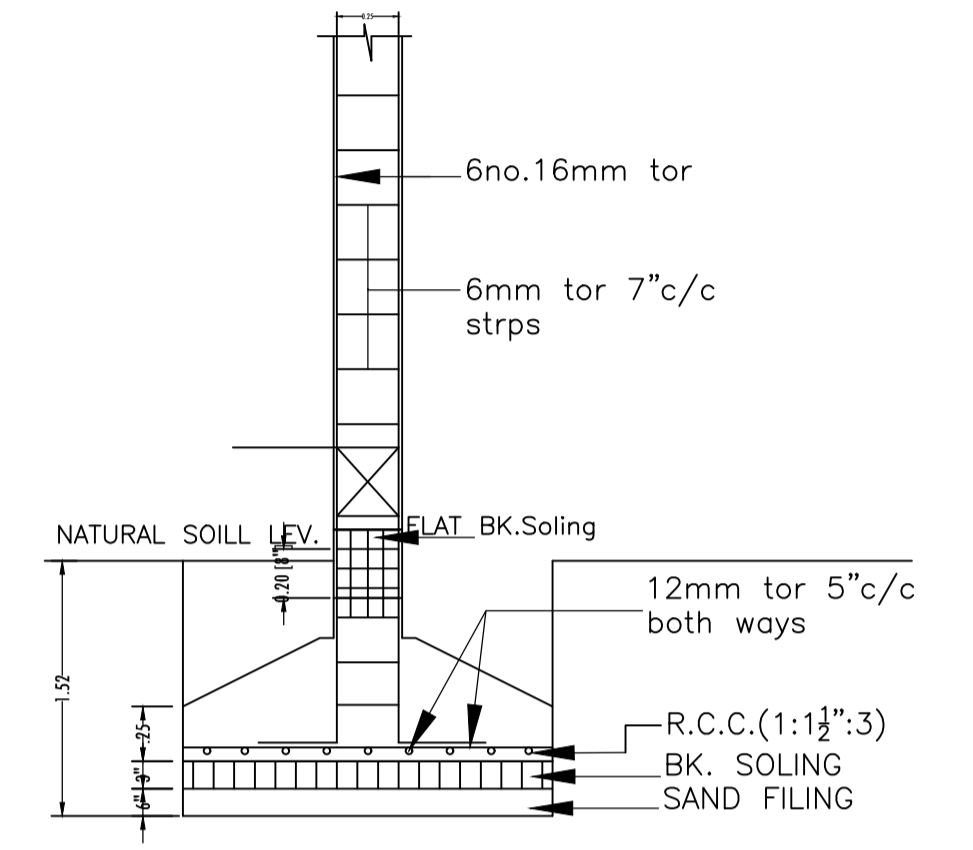

SEC. X-Y
R.C.C. COLUMN FDN.DETAIL
SCALE 1" = 2'-0"

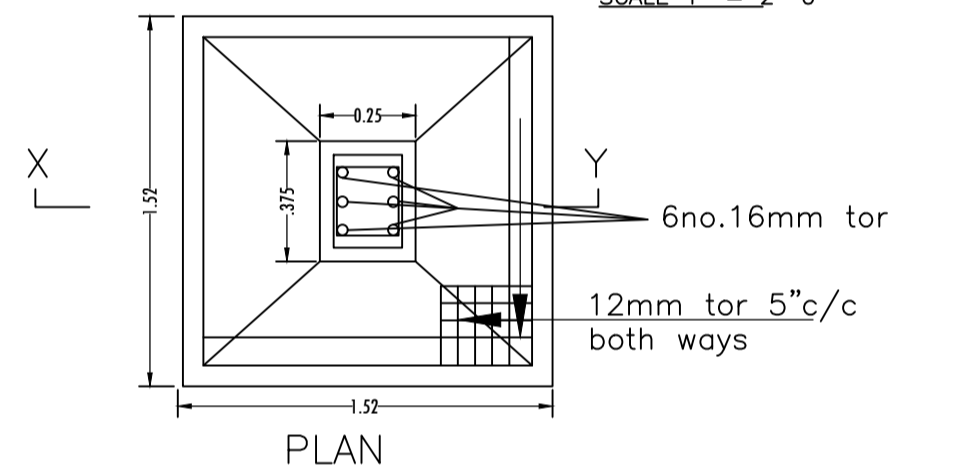

PLAN
SCALE - 1":2'-0"

LTP NAME AND SIGNATURE	STRUCTURAL ENG'S NAME AND SIGNATURE	BUILDER NAME AND SIGNATURE	DIGITAL SIGNATURE
MD.SHOAIB ALAM JNP/ENG/0001/2017			