

SITE PLAN

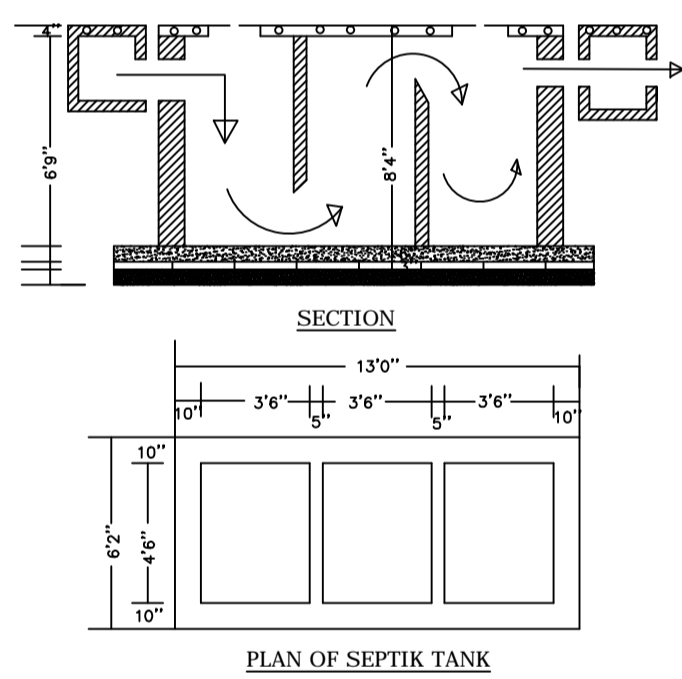

PLAN OF SEPTIC TANK

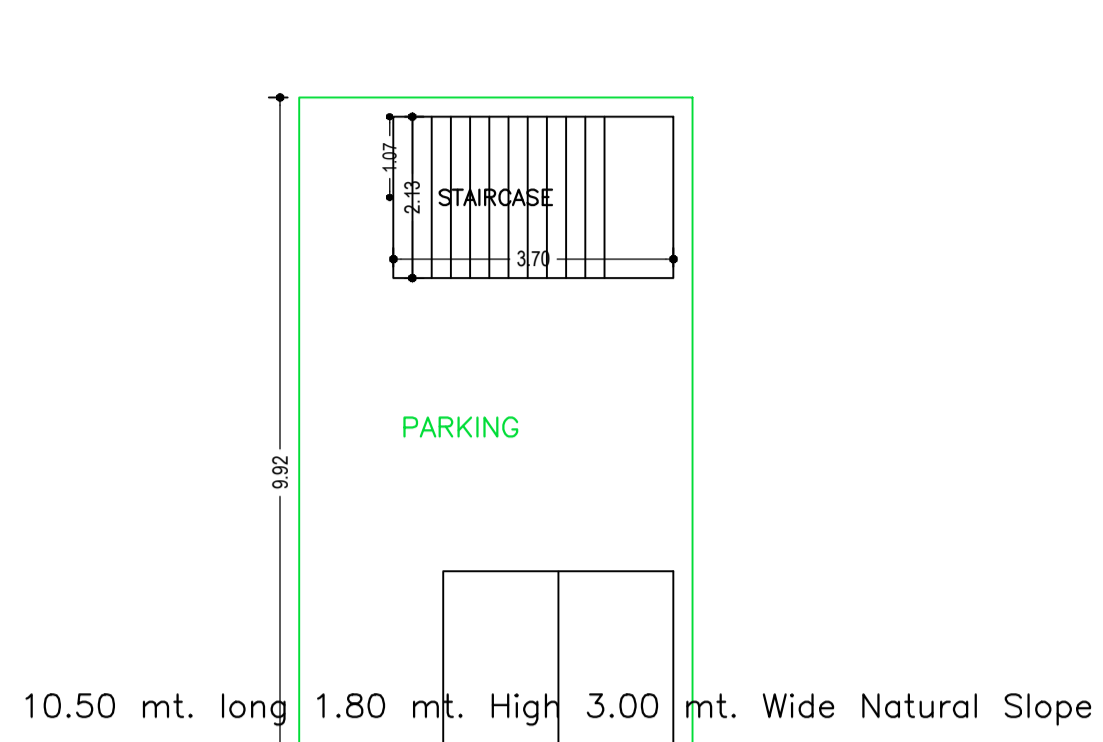

BASEMENT FLOOR PLAN (SCALE 1:100)

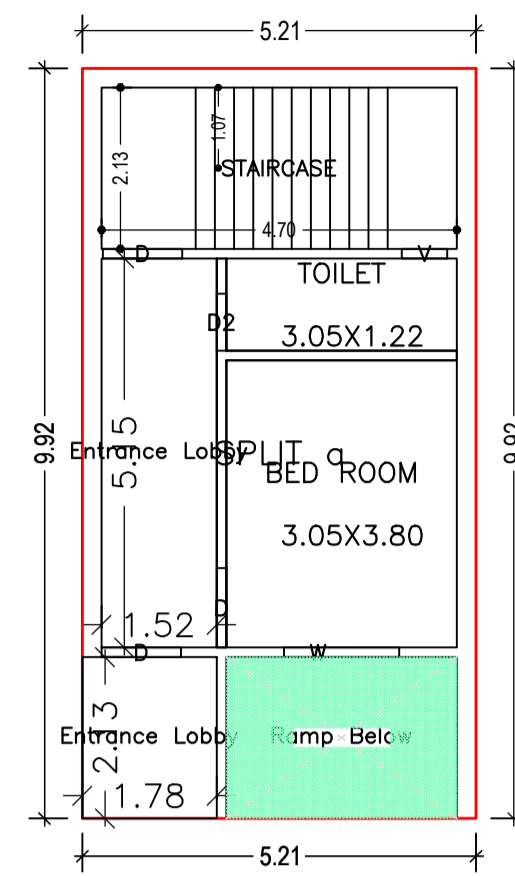

GROUND FLOOR PLAN (Proposed) (SCALE 1:100)

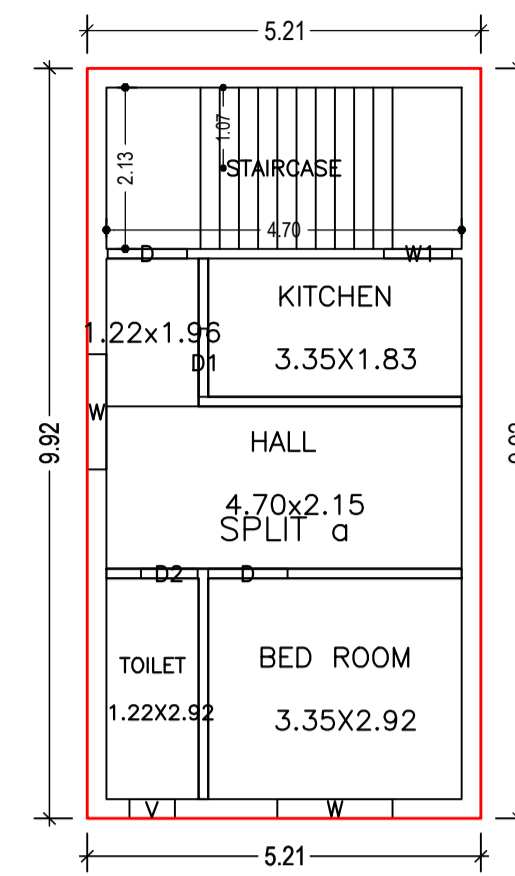

TYPICAL - 1 & 2 FLOOR PLAN (Proposed) (SCALE 1:100)

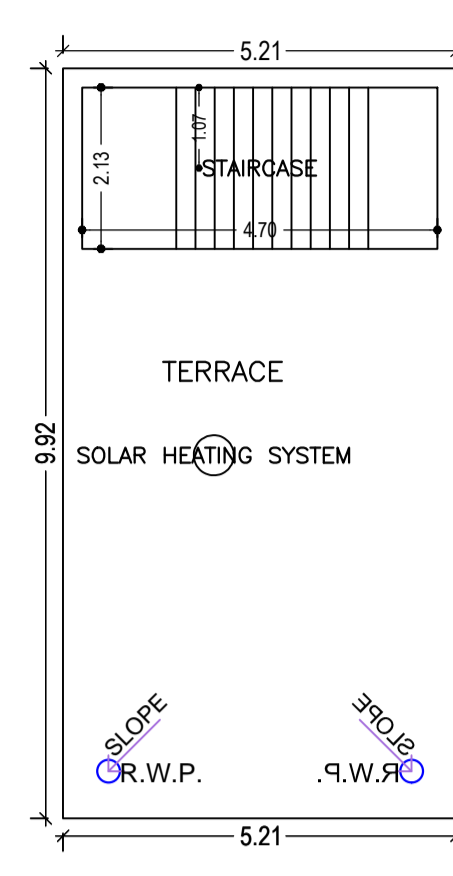

TERRACE FLOOR PLAN (SCALE 1:100)

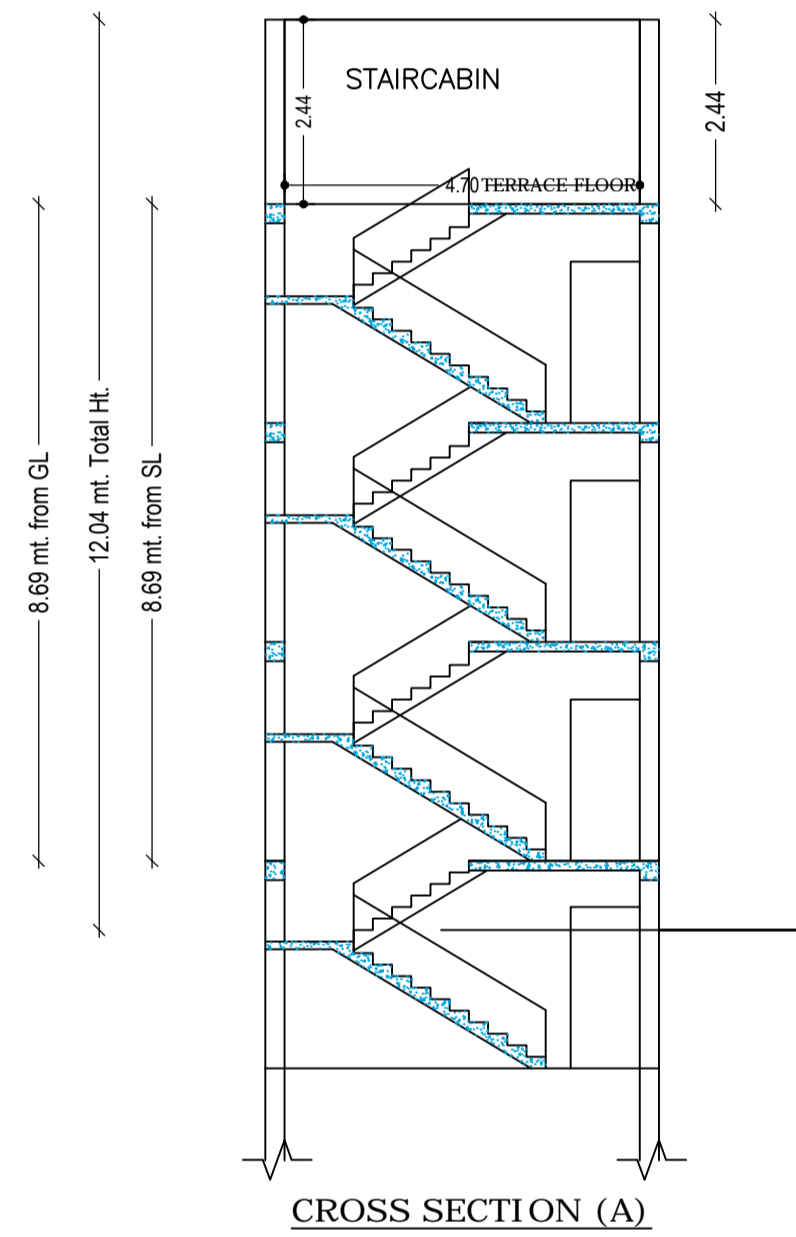

CROSS SECTION (A)

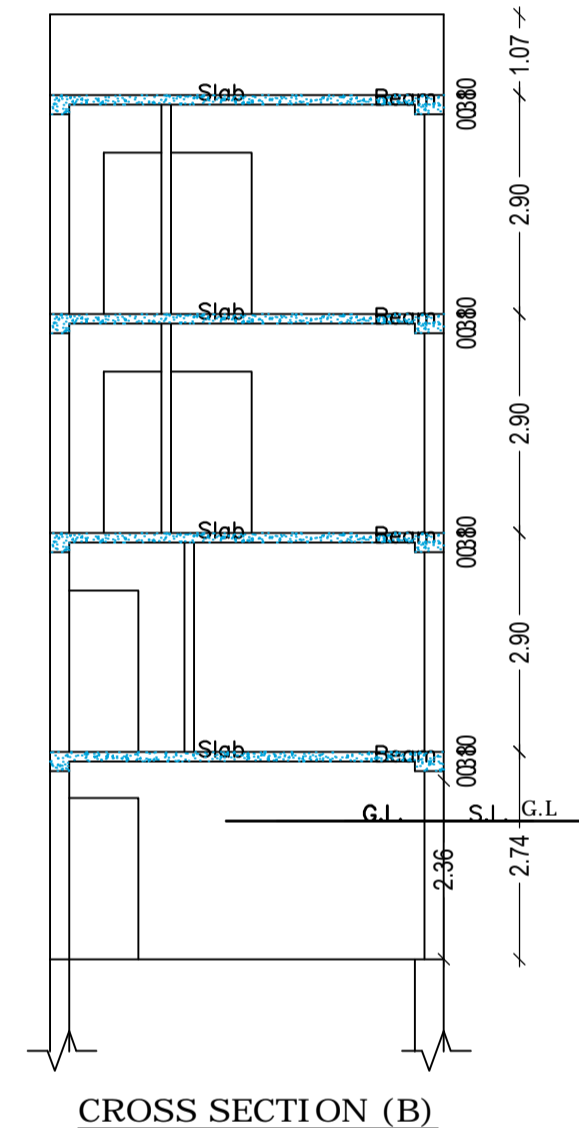

CROSS SECTION (B)

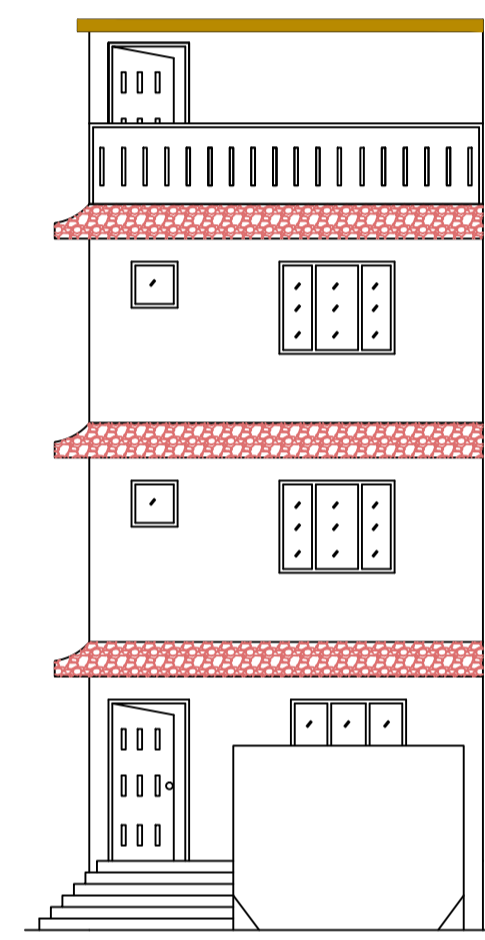

FRONT ELEVATION

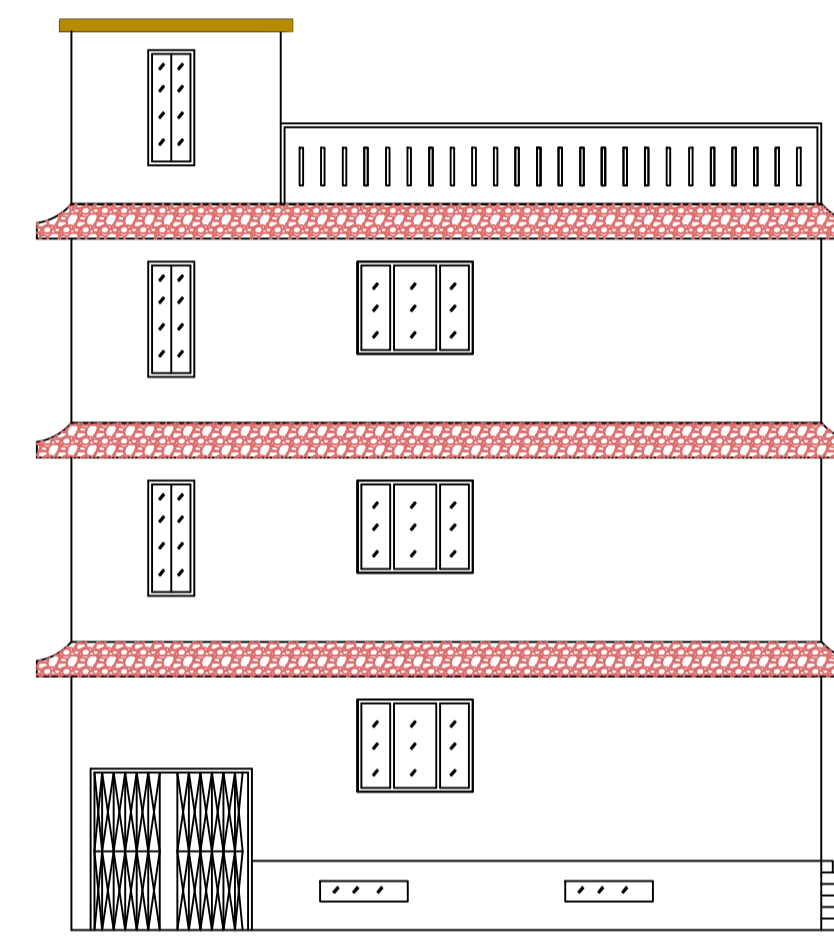

CROSS ELEVATION

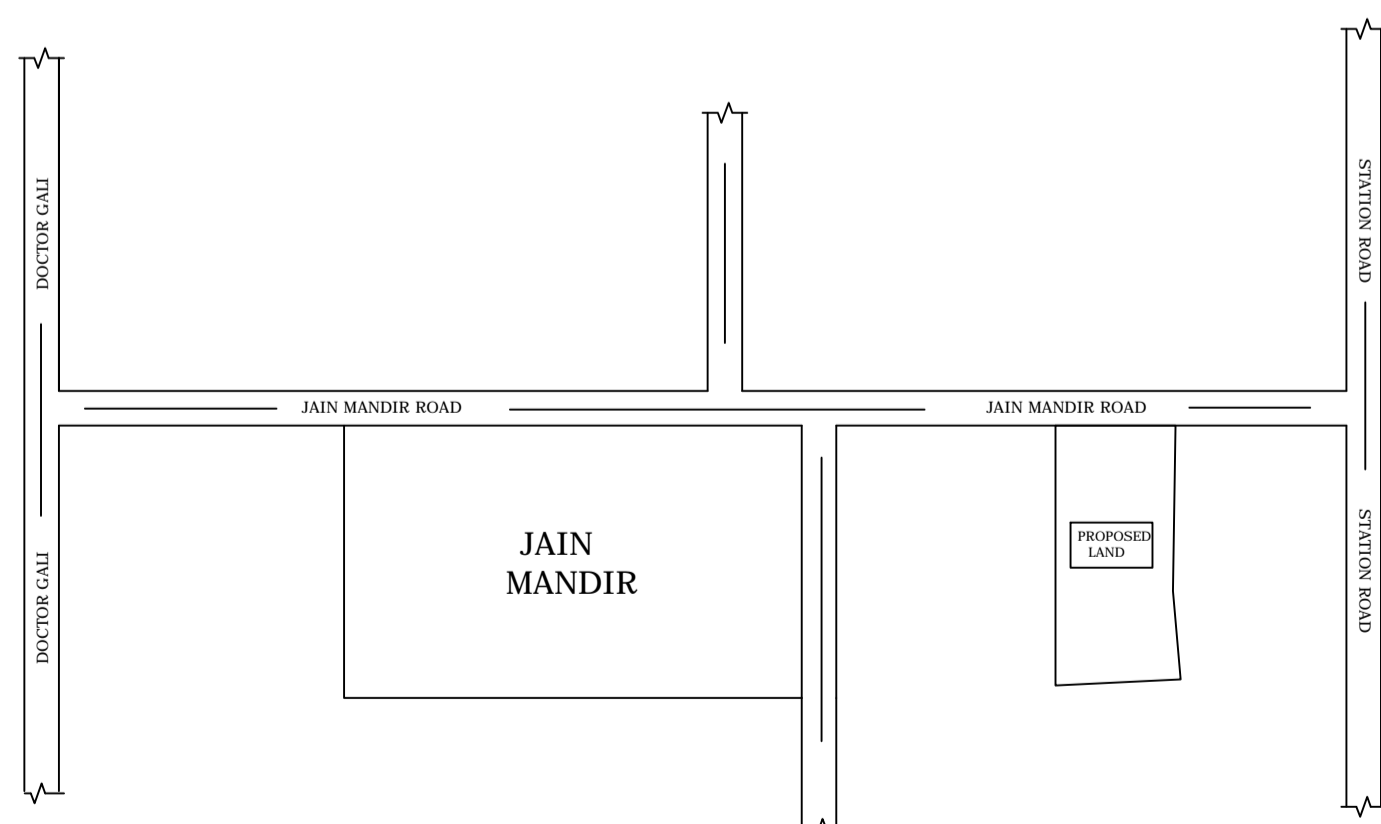

LOCATION PLAN (SCALE -1''=16')

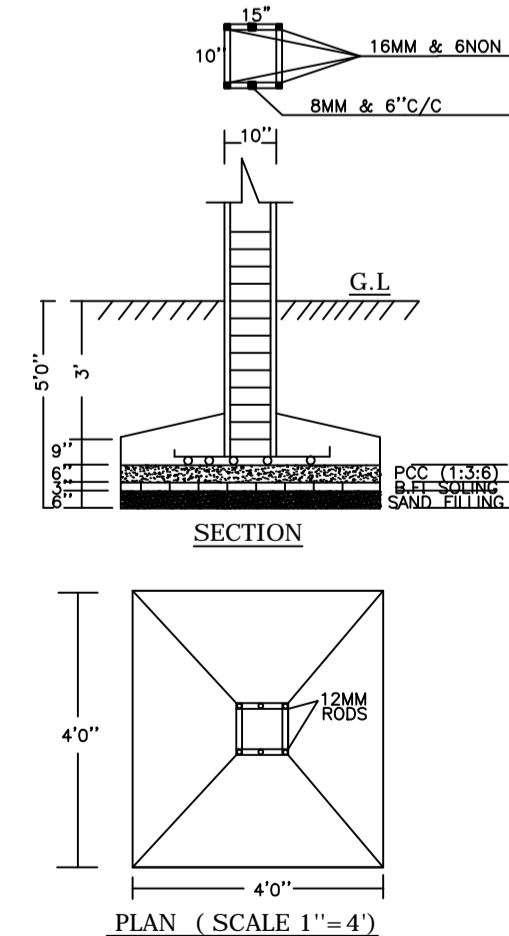

PLAN (SCALE 1''=4')

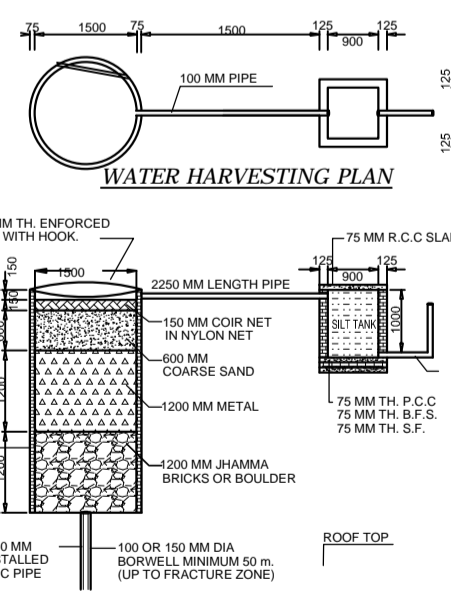

WATER HARVESTING PLAN

UnitBUA Table for Building :A (RESIDENTIAL)

FLOOR	Name	UnitBUA Type	UnitBUA Area	Carpert Area	No. of Rooms	No. of Tenement
TYPICAL - 1 & 2 FLOOR PLAN	SPLIT a	FLAT	0.00	0.00	4	0
GROUND FLOOR PLAN	SPLIT a	FLAT	91.41	87.09	2	1
Total:	-	-	91.41	87.09	10	1

SCHEDULE OF DOOR:

BUILDING NAME	NAME	LENGTH	HEIGHT	NOS
A (RESIDENTIAL)	D2	0.75	2.10	03
A (RESIDENTIAL)	D1	0.90	2.10	02
A (RESIDENTIAL)	D	1.05	2.10	05

SCHEDULE OF WINDOW/VENTILATION:

BUILDING NAME	NAME	LENGTH	HEIGHT	NOS
A (RESIDENTIAL)	V	0.60	1.20	03
A (RESIDENTIAL)	W1	0.90	1.20	02
A (RESIDENTIAL)	W	1.52	1.20	05

FAR & Tenement Details (Table 4c-1)

Building	No. of Same Bldg	Total Built Up Area (Sq.mt.)	Deductions (Area in Sq.mt.)			Proposed FAR Area (Sq.mt.)	Add Area In FAR (Sq.mt.)	Total FAR Area (Sq.mt.)	Total Consumed Additional FAR Area (Sq.mt.)	Tnmt (No.)
			Void	Accessory Use	Parking					
A (RESIDENTIAL)	1	206.64	6.50	11.64	32.61	136.84	7.90	144.74	144.74	01
Grand Total	1	206.64	6.50	11.64	32.61	136.84	7.90	144.74	144.74	01

COLOR INDEX

PLOT BOUNDARY	Black
ABUTTING ROAD	Red
PROPOSED CONSTRUCTION	Green
COMMON PLOT	Blue
ROAD WIDENING AREA	Yellow
EXISTING (To be retained)	Orange
EXISTING (To be demolished)	White

LTP NAME AND SIGNATURE

KIRAN KUMARI  
JNP/ENG/001/2019

Building :A (RESIDENTIAL)

Floor Name	Total Built Up Area (Sq.mt.)	Deductions (Area in Sq.mt.)			Proposed FAR Area (Sq.mt.)	Add Area In FAR (Sq.mt.)	Total FAR Area (Sq.mt.)	Total Consumed Additional FAR Area (Sq.mt.)	Tnmt (No.)
		Void	Accessory Use	Parking					
Basement Floor	51.66	0.00	0.00	32.61	0.00	7.90	7.90	7.90	00
Ground Floor	51.66	6.50	11.64	0.00	33.52	0.00	33.52	33.52	01
First Floor	51.66	0.00	0.00	0.00	51.66	0.00	51.66	51.66	00
Second Floor	51.66	0.00	0.00	0.00	51.66	0.00	51.66	51.66	00
Terrace Floor	0.00	0.00	0.00	0.00	0.00	0.00	0.00	0.00	00
Total:	206.64	6.50	11.64	32.61	136.84	7.90	144.74	144.74	01

Building USE/SUBUSE Details

Building Name	Building Use	Building SubUse	Building Structure
A (RESIDENTIAL)	Residential	Bungalow/ Dwelling / Non Apartment	Non-Highrise

STRUCTURAL ENG'S NAME AND SIGNATURE

BUILDER NAME AND SIGNATURE

DIGITAL SIGNATURE

AREA STATEMENT		VERSION NO. : 1.0.62	SQ.MT.
JHUMRITILAIYA NAGAR PARISHAD		VERSION DATE: 16/10/2020	
PROJECT DETAIL:			
Region: JHARKHAND URBAN LOCAL BODIES		Plot Use: Residential	
District: KODERMA		Plot SubUse: Bungalow/ Dwelling / Non Apartment	
Authority: JHUMRITILAIYA NAGAR PARISHAD		PlotNearbyReligiousStructure: NA	
Inward No: JNP/BP/0048/W15/2022		PlotSubPlotNo: 7532	
Application Type: General Proposal		North: Plot No. - SRI PRADEEP KHATUWALA	
Project Type: Building Permission		South: Plot No. - HOUSE OF NU VENDOR AND SMT PRAMITA KHATUWALA	
Nature of Development: New		East: Plot No. - HOUSE OF SRI LAKHPATIYA	
Location of Development Area: Old Area		West: Road Width - 4.87	
AREA DETAILS:			
AREA OF PLOT (Minimum)	(A)		85.96
NET AREA OF PLOT(Gross Plot Area - Deduction from Gross Plot area)	(A-Deductions)		85.96
Deduction for Balance Plot Area(from Gross Plot Area)			
Common Plot			13.49
Total			13.49
BALANCE AREA OF PLOT(Net Plot Area - Recreational/Amenity space)	(A-Deductions)		72.46
PLOT AREA FOR COVERAGE(Net Plot Area)	(A-Deductions)		85.96
Plot Area for FAR (Net Plot Area + Road/Widening Area)	(A-Deductions)		85.96
COVERAGE CHECK			
Permissible Coverage area ( 70.00 % )			60.17
Proposed Coverage Area ( 60.10 % )			51.66
Total Prop. Coverage Area ( 60.1 % )			51.66
Balance coverage area ( 9.90 % )			8.51
FAR CHECK			
Perm. FAR Area ( 1.80 )			154.73
Total Perm. FAR area			154.73
Residential FAR			136.85
Proposed FAR Area			144.75
Total Proposed FAR Area			144.75
Consumed FAR (Factor)			1.68
Balance FAR Area			9.98
BUILT UP AREA CHECK			
Total Proposed BuiltUp Area			206.64
ARCHITECT (Regd)		KIRAN KUMARI	
ENGINEER (Regd)			
SUPERVISOR (Regd)			
OWNER (Regd)		SMT SUSHMA DEVI	
DEVELOPMENT AUTHORITY		LOCAL BODY	

Buildingwise Floor FAR Details

Floor Name	Building Name A (RESIDENTIAL)		Total	
	Proposed Built Up Area (Sq.mt.)	Proposed FAR Area (Sq.mt.)	Total Proposed Built Up Area (Sq.mt.)	Total FAR Area (Sq.mt.)
Basement Floor	51.66	7.90	51.66	7.90
Ground Floor	51.66	33.52	51.66	33.52
First Floor	51.66	51.66	51.66	51.66
Second Floor	51.66	51.66	51.66	51.66
Terrace Floor	0.00	0.00	0.00	0.00
Total:	206.64	144.74	206.64	144.74