

Proposal Basic Information

Proposal File No.	JNP/BP/0119/W12/2022
Owner Name	SMT PUNAM DEVI
Khata No	1230
Plot No	7321
Village Name	Tilaiya
Use	Residential
SubUse	Bungalow/ Dwelling / Non Apartment

FAR & Tenement Details (Table 4c-1)

Building	No. of Same Bldg	Total Built Up Area (Sq.mt.)	Proposed FAR Area (Sq.mt.) Resi.	Total FAR Area (Sq.mt.)	Total Consumed Additional FAR Area (Sq.mt.)	Trmt (No.)
AA (SMT PUNAM DEVI)	1	65.56	65.56	65.56	65.56	01
Grand Total	1	65.56	65.56	65.56	65.56	01

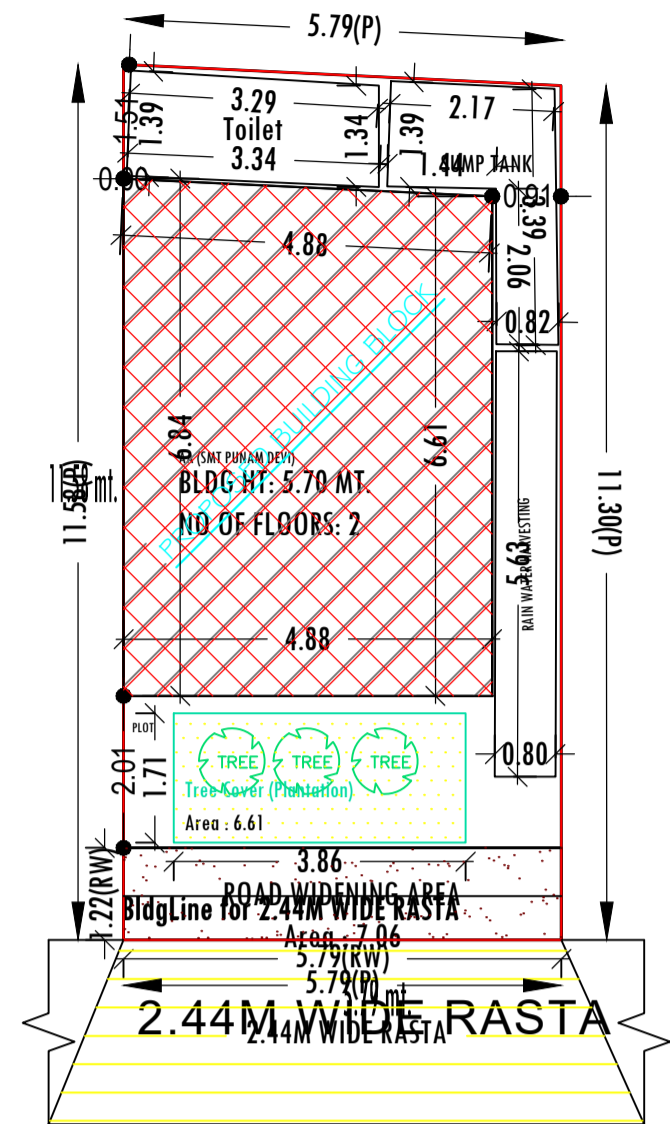

**SITE PLAN**  
SCALE :- 1=100

**SITE PLAN**

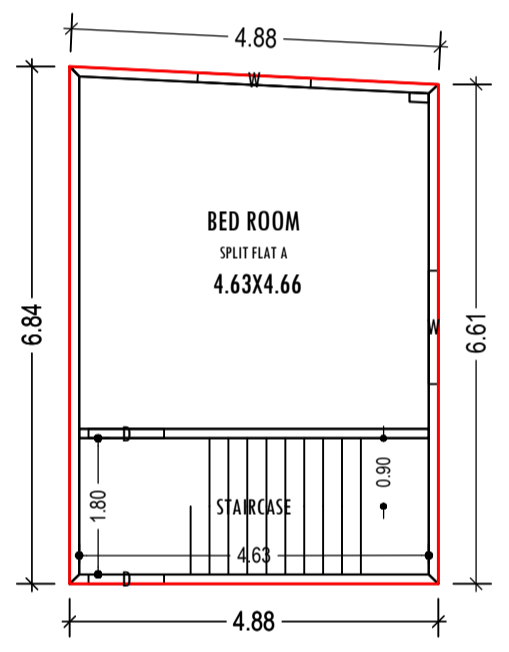

**GROUND FLOOR PLAN (Proposed)**  
SCALE 1:100

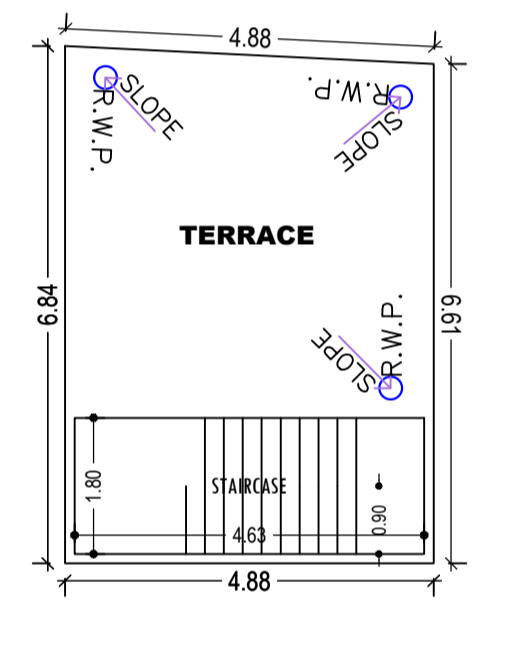

**TERRACE FLOOR PLAN (SCALE 1:100)**

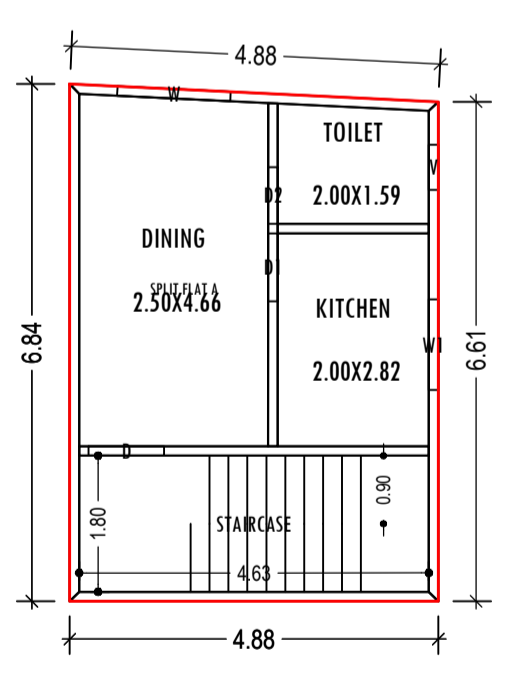

**FIRST FLOOR PLAN (Proposed)**  
SCALE 1:100

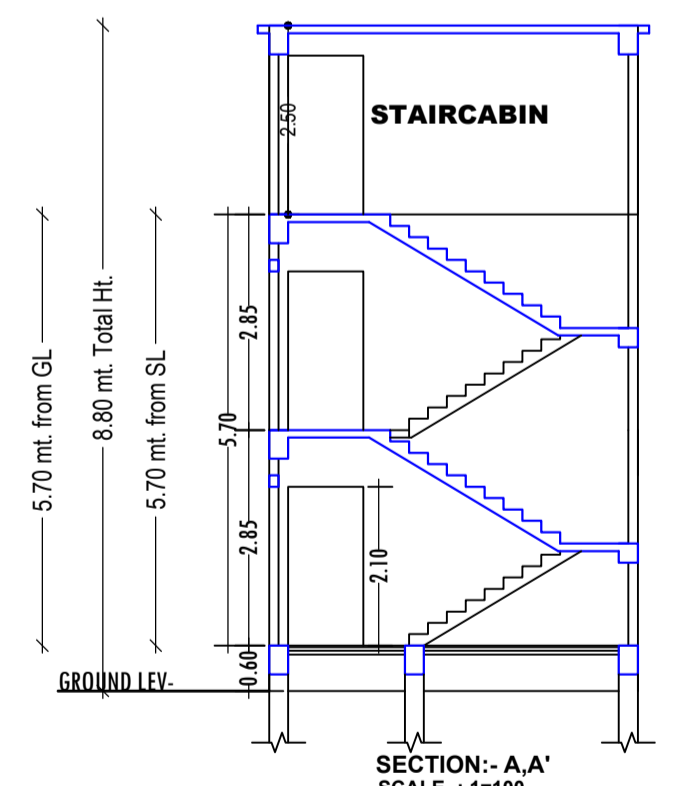

**SECTION:- A-A'**  
SCALE :- 1=100

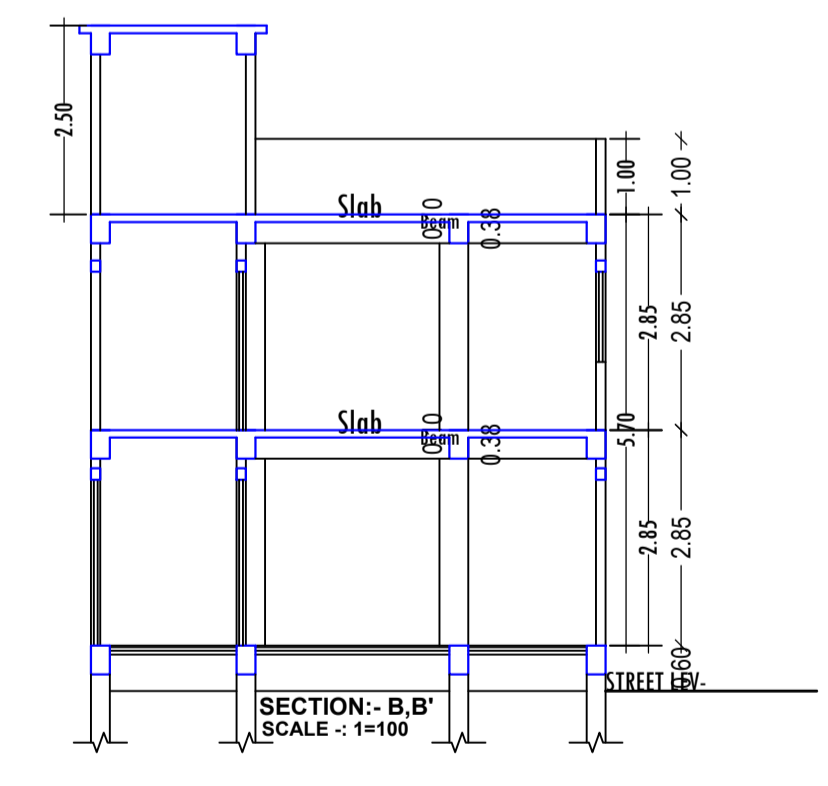

**SECTION:- B,B'**  
SCALE :- 1=100

**SCHEDULE OF DOOR:**

BUILDING NAME	NAME	LENGTH	HEIGHT	NOS
AA (SMT PUNAM DEVI)	D2	0.75	2.10	01
AA (SMT PUNAM DEVI)	D1	0.90	2.10	01
AA (SMT PUNAM DEVI)	D	1.00	2.10	02

**SCHEDULE OF WINDOW/VENTILATION:**

BUILDING NAME	NAME	LENGTH	HEIGHT	NOS
AA (SMT PUNAM DEVI)	V	0.60	0.60	01
AA (SMT PUNAM DEVI)	W1	1.20	1.20	01
AA (SMT PUNAM DEVI)	W	1.50	1.20	03

**UnitBUA Table for Building :AA (SMT PUNAM DEVI)**

FLOOR	Name	UnitBUA Type	UnitBUA Area	Carpet Area	No. of Rooms	No. of Tenement
GROUND FLOOR PLAN	SPLIT FLAT A	FLAT	42.08	41.23	1	1
FIRST FLOOR PLAN	SPLIT FLAT A	FLAT	0.00	0.00	3	0
Total:	-	-	42.08	41.23	4	1

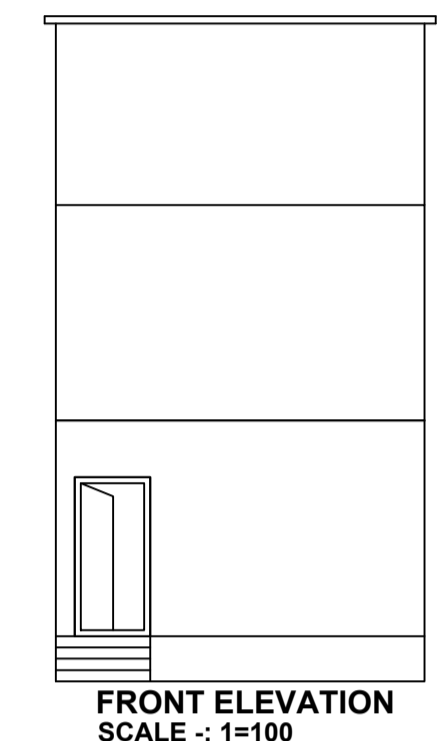
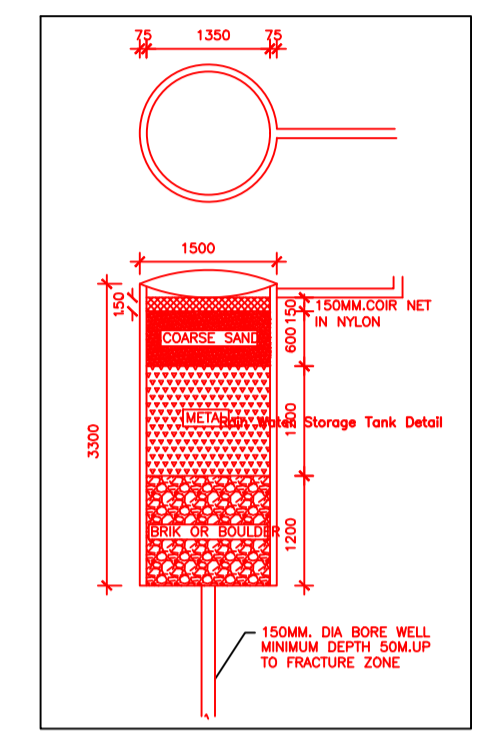
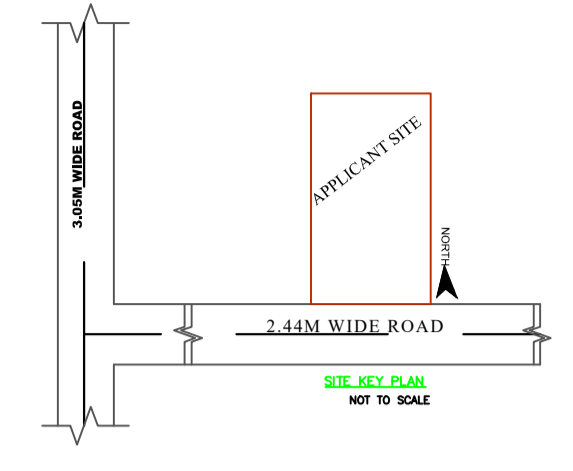

**FRONT ELEVATION**  
SCALE :- 1=100

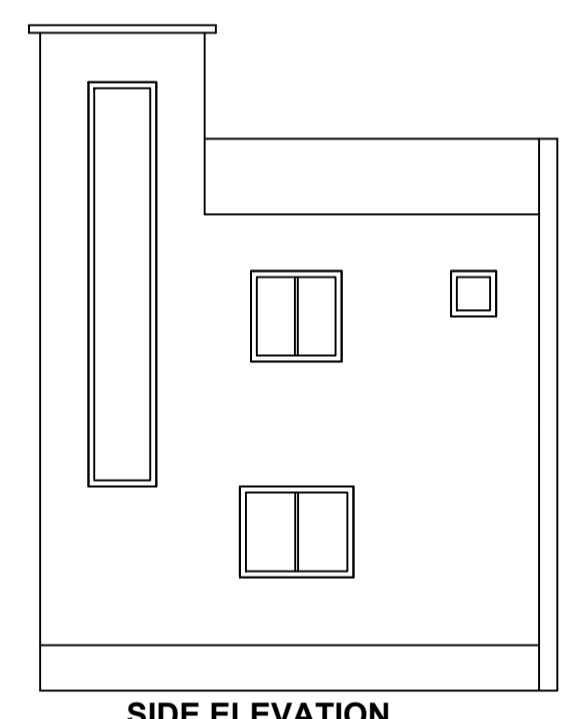

**SIDE ELEVATION**  
SCALE :- 1=100

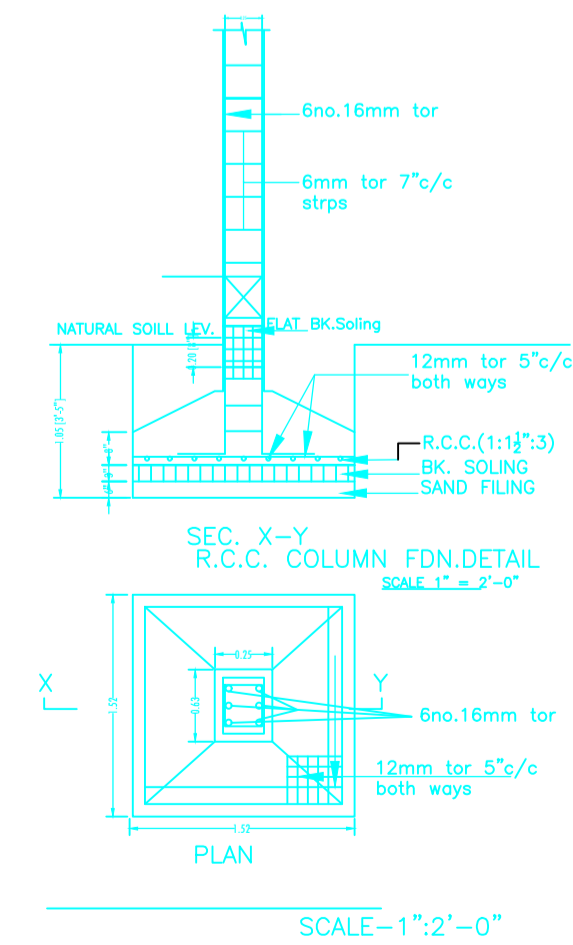

**SCALE :- 1"=2'-0"**

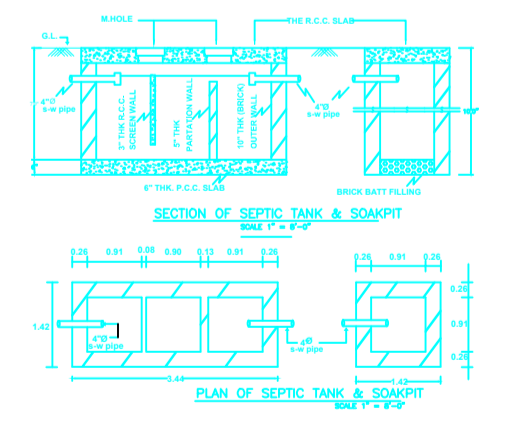

AREA STATEMENT	VERSION NO. : 1.0.65
JHUMRITILAYA NAGAR PARISHAD	VERSION DATE: 16/10/2020
PROJECT DETAIL:	
Region: JHARKHAND URBAN LOCAL BODIES	Plot Use: Residential
District: KODERMA	Plot SubUse: Bungalow/ Dwelling / Non Apartment
Authority: JHUMRITILAYA NAGAR PARISHAD	PlotNearby/ReligiousStructure: NA
Inward No: JNP/BP/0119/W12/2022	Plot/SubPlot No: 7321
Application Type: General Proposal	North: Plot No. - LAND OF SRI MUNSHI SINGH
Project Type: Building Permission	South: Road Width - 2.44M WIDE RASTA
Nature of Development: New	East: Plot No. - LAND OF SRI RAJENDAR PANDIT
Location of Development Area: Old Area	West: Plot No. - LAND OF SMT PUNAM DEVI & RAJENDAR PRASAD
AREA DETAILS:	SQ.MT.
AREA OF PLOT (Minimum)	(A) 66.23
Deduction for NetPlot Area	
Road Widening Area	7.06
Total	7.06
NET AREA OF PLOT(Gross Plot Area - Deduction from Gross Plot area)	(A-Deductions) 59.17
Deduction for Balance Plot Area(from Gross Plot Area)	
Road Widening Area	7.06
Common Plot	6.61
Total	13.67
BALANCE AREA OF PLOT(Net Plot Area - Recreational/Amenity space)	(A-Deductions) 52.56
PLOT AREA FOR COVERAGE(Net Plot Area)	(A-Deductions) 59.17
Plot Area for FAR (Net Plot Area + RoadWidening Area)	(A-Deductions) 59.17
COVERAGE CHECK	
Permissible Coverage area ( 70.00 % )	41.42
Proposed Coverage Area ( 55.40 % )	32.78
Total Prop. Coverage Area ( 55.4 % )	32.78
Balance coverage area ( 14.60 % )	8.64
FAR CHECK	
Perm. FAR Area ( 1.200 )	71.00
Total Perm. FAR area	71.00
Residential FAR	65.57
Proposed FAR Area	65.57
Total Proposed FAR Area	65.57
Consumed FAR (Factor)	1.11
Balance FAR Area	5.43
BUILT UP AREA CHECK	
Total Proposed BuiltUp Area	65.56
ARCHITECT (Regd)	MD SHOAB ALAM
ENGINEER (Regd)	
SUPERVISOR (Regd)	
OWNER (Regd)	SMT PUNAM DEVI
DEVELOPMENT AUTHORITY	LOCAL BODY

COLOR INDEX	
PLOT BOUNDARY	Black
ABUTTING ROAD	Red
PROPOSED CONSTRUCTION	Green
COMMON PLOT	Yellow
ROAD WIDENING AREA	Blue
EXISTING (To be retained)	Light Blue
EXISTING (To be demolished)	White

**Buildingwise Floor FAR Details**

Floor Name	Building Name AA (SMT PUNAM DEVI)		Total	
	Proposed Built Up Area (Sq.mt.)	Proposed FAR Area (Sq.mt.)	Total Proposed Built Up Area (Sq.mt.)	Total FAR Area (Sq.mt.)
Ground Floor	32.78	32.78	32.78	32.78
First Floor	32.78	32.78	32.78	32.78
Terrace Floor	0.00	0.00	0.00	0.00
Total :	65.56	65.56	65.56	65.56

**Building USE/SUBUSE Details**

Building Name	Building Use	Building SubUse	Building Structure
AA (SMT PUNAM DEVI)	Residential	Bungalow/ Dwelling / Non Apartment	Non-Highrise

LTP NAME AND SIGNATURE	STRUCTURAL ENG'S NAME AND SIGNATURE	BUILDER NAME AND SIGNATURE	DIGITAL SIGNATURE
MD SHOAB ALAM JNP/ENG/0001/2017			