

SITE PLAN
SCALE :- 1=100

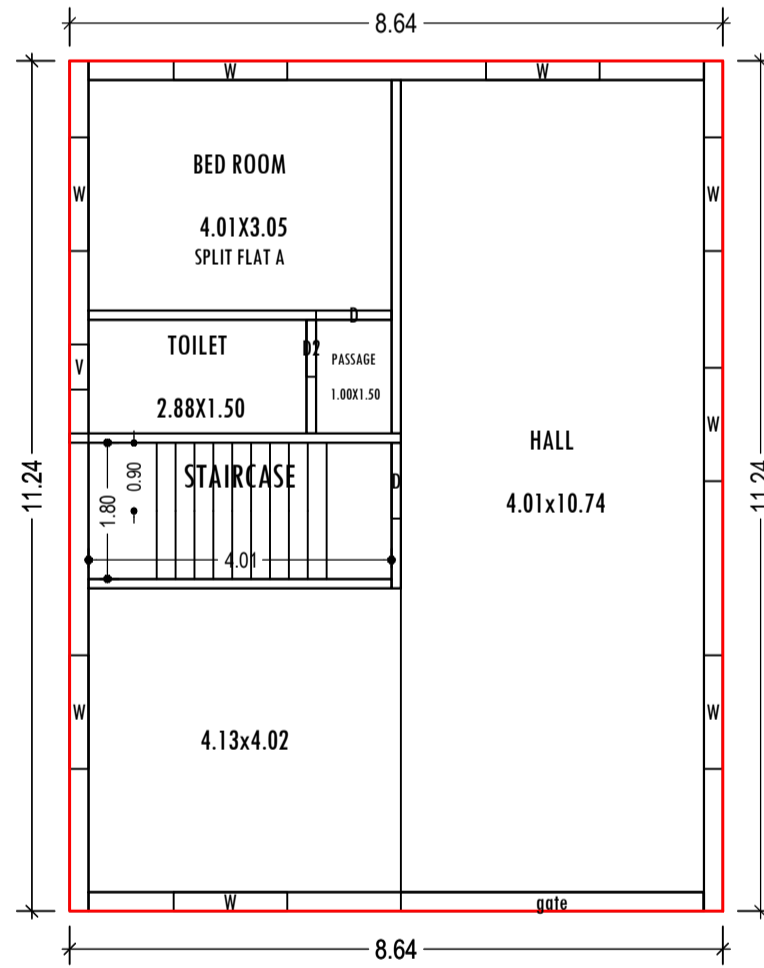

GROUND FLOOR PLAN
(Proposed)
SCALE 1:100

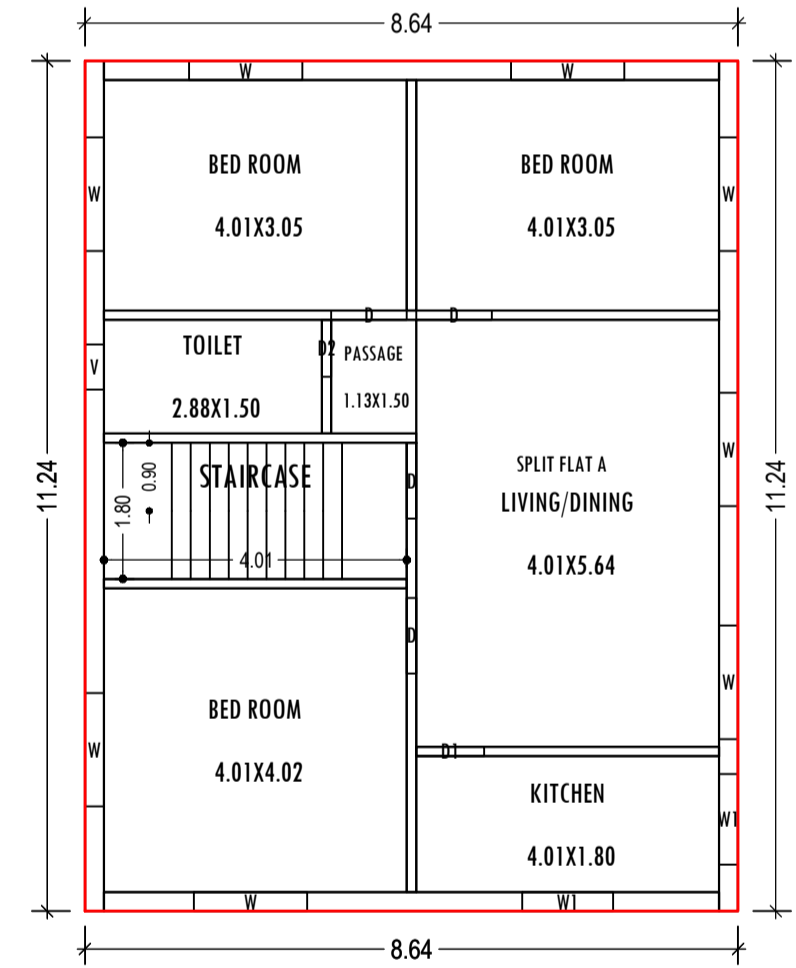

FIRST FLOOR PLAN
(Proposed)
SCALE 1:100

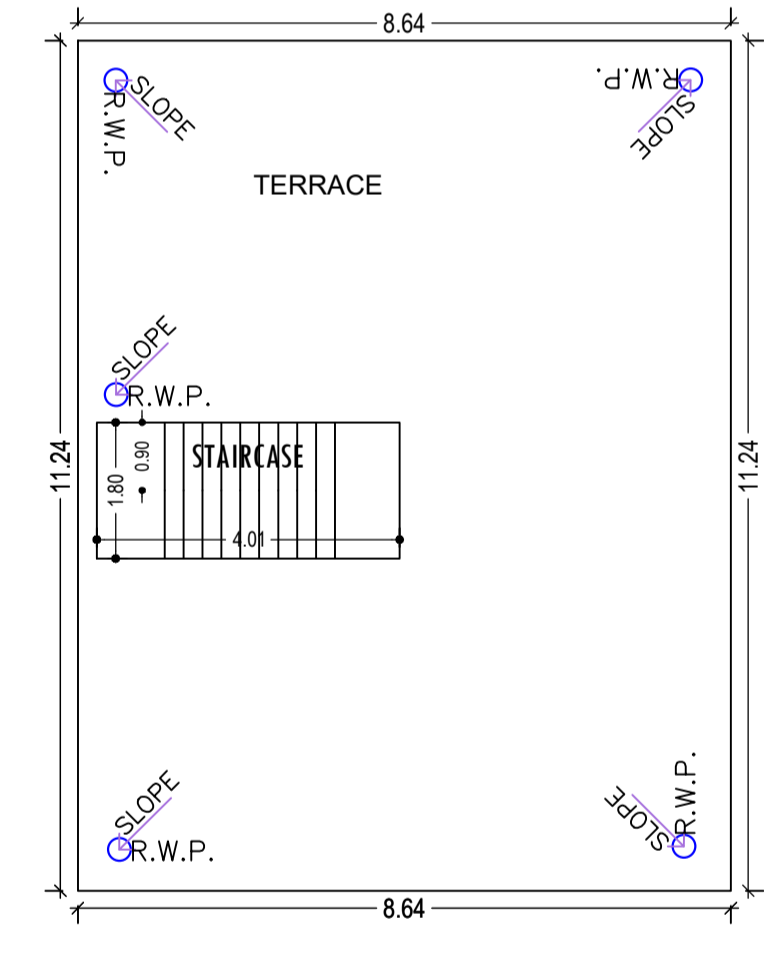

TERRACE FLOOR PLAN
(Proposed)
SCALE 1:100

SCHEDULE OF DOOR:

BUILDING NAME	NAME	LENGTH	HEIGHT	NOS
AA (SMT ANGELA SINGH)	D2	0.75	2.10	02
AA (SMT ANGELA SINGH)	D1	0.90	2.10	01
AA (SMT ANGELA SINGH)	D	1.00	2.10	06
AA (SMT ANGELA SINGH)	gate	4.00	2.10	01

SCHEDULE OF WINDOW/VENTILATION:

BUILDING NAME	NAME	LENGTH	HEIGHT	NOS
AA (SMT ANGELA SINGH)	V	0.60	0.60	02
AA (SMT ANGELA SINGH)	W1	1.20	1.20	02
AA (SMT ANGELA SINGH)	W	1.50	1.20	16

UnitBUA Table for Building :AA (SMT ANGELA SINGH)

FLOOR	Name	UnitBUA Type	UnitBUA Area	Carpet Area	No. of Rooms	No. of Tenement
GROUND FLOOR PLAN	SPLIT FLAT A	FLAT	157.95	154.59	4	1
FIRST FLOOR PLAN	SPLIT FLAT A	FLAT	0.00	0.00	7	0
Total:	-	-	157.95	154.59	11	1

Building :AA (SMT ANGELA SINGH)

Floor Name	Total Built Up Area (Sq.mt.)	Proposed FAR Area (Sq.mt.) Resi.	Total FAR Area (Sq.mt.)	Total Consumed Additional FAR Area (Sq.mt.)	Tnmt (No.)
Ground Floor	97.13	97.13	97.13	97.13	01
First Floor	97.13	97.13	97.13	97.13	00
Terrace Floor	0.00	0.00	0.00	0.00	00
Total :	194.26	194.26	194.26	194.26	01
Total Number of Same Buildings	1				
Total :	194.26	194.26	194.26	194.26	01

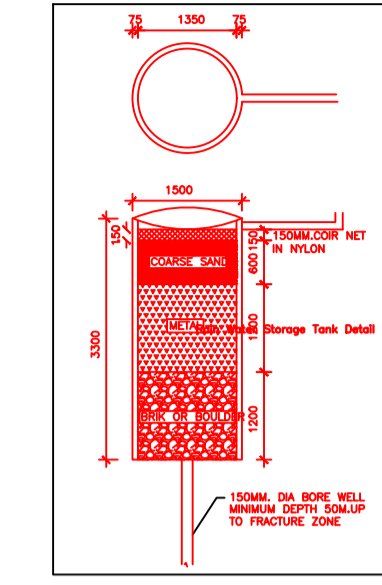

FAR & Tenement Details (Table 4c-1)

Building	No. of Same Bldg	Total Built Up Area (Sq.mt.)	Proposed FAR Area (Sq.mt.) Resi.	Total FAR Area (Sq.mt.)	Total Consumed Additional FAR Area (Sq.mt.)	Tnmt (No.)
AA (SMT ANGELA SINGH)	1	194.26	194.26	194.26	194.26	01
Grand Total :	1	194.26	194.26	194.26	194.26	01

Proposal Basic Information

Proposal File No.	JNP/BP/0114/W/12/2022
Owner Name	SMT ANGELA SINGH
Khata No	1302
Plot No	7343
Village Name	Tilaiya
Use	Residential
SubUse	Bungalow/ Dwelling / Non Apartment

AREA STATEMENT		VERSION NO. : 1.0.65
JHUMRITILAIYA NAGAR PARISHAD		VERSION DATE: 16/10/2020
PROJECT DETAIL:		
Region: JHARKHAND URBAN LOCAL BODIES	Plot Use: Residential	
District: KODERMA	Plot SubUse: Bungalow/ Dwelling / Non Apartment	
Authority: JHUMRITILAIYA NAGAR PARISHAD	PlotNearbyReligiousStructure: NA	
Inward No: JNP/BP/0114/W/12/2022	Plot/SubPlot No: 7343	
Application Type: General Proposal	North: Plot No. - KAILASH YADAV	
Project Type: Building Permission	South: Plot No. - VIJAY SINGH	
Nature of Development: New	East: Road Width - 3.05M WIDE ROAD	
Location of Development Area: Old Area	West: Plot No. - HOUSE OF AJAY KUMAR SINGH	
AREA DETAILS:		
AREA OF PLOT (Minimum)	(A)	168.34 SQ.MT.
Deduction for NetPlot Area		
Road Widening Area		6.20
Total		6.20
NET AREA OF PLOT(Gross Plot Area - Deduction from Gross Plot area)	(A-Deductions)	162.14
Deduction for Balance Plot Area(from Gross Plot Area)		
Road Widening Area		6.20
Common Plot		16.07
Total		22.27
BALANCE AREA OF PLOT(Net Plot Area - Recreational/Amenity space)	(A-Deductions)	146.07
PLOT AREA FOR COVERAGE(Net Plot Area)	(A-Deductions)	162.14
Plot Area for FAR (Net Plot Area + RoadWidening Area)	(A-Deductions)	162.14
COVERAGE CHECK		
Permissible Coverage area (70.00 %)		113.50
Proposed Coverage Area (59.90 %)		97.13
Total Prop. Coverage Area (59.9 %)		97.13
Balance coverage area (10.10 %)		16.37
FAR CHECK		
Perm. FAR Area (1.200)		194.57
Total Perm. FAR area		194.57
Residential FAR		194.27
Proposed FAR Area		194.27
Total Proposed FAR Area		194.27
Consumed FAR (Factor)		1.20
Balance FAR Area		0.30
BUILT UP AREA CHECK		
Total Proposed BuiltUp Area		194.26
ARCHITECT (Regd)	MD SHOAB ALAM	
ENGINEER (Regd)		
SUPERVISOR (Regd)		
OWNER (Regd)	SMT ANGELA SINGH	
DEVELOPMENT AUTHORITY		LOCAL BODY

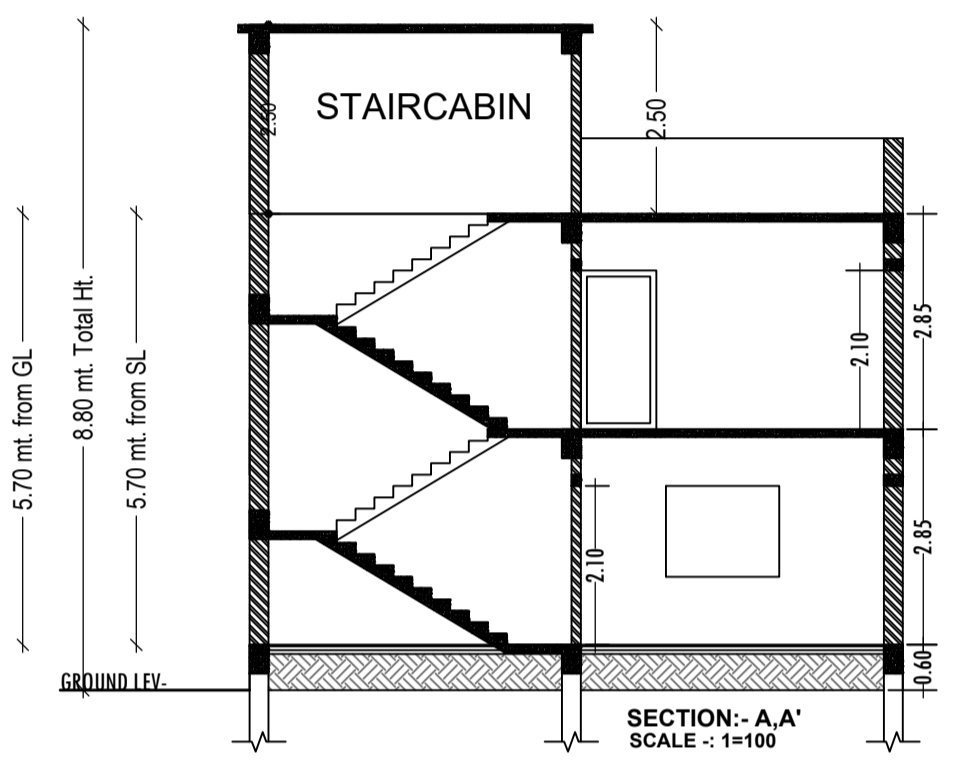
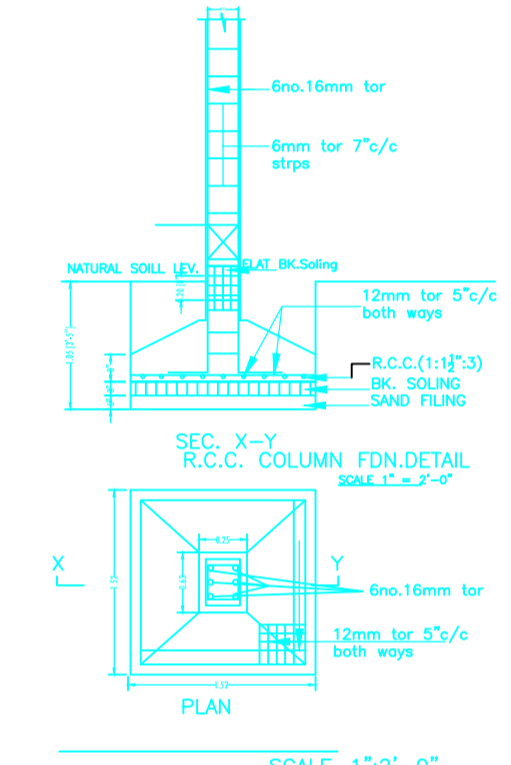
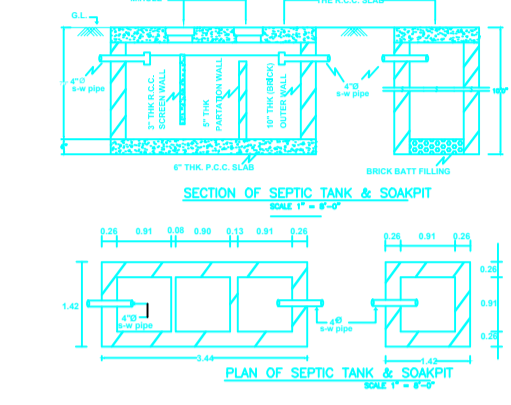

SECTION- A.A'
SCALE :- 1=100

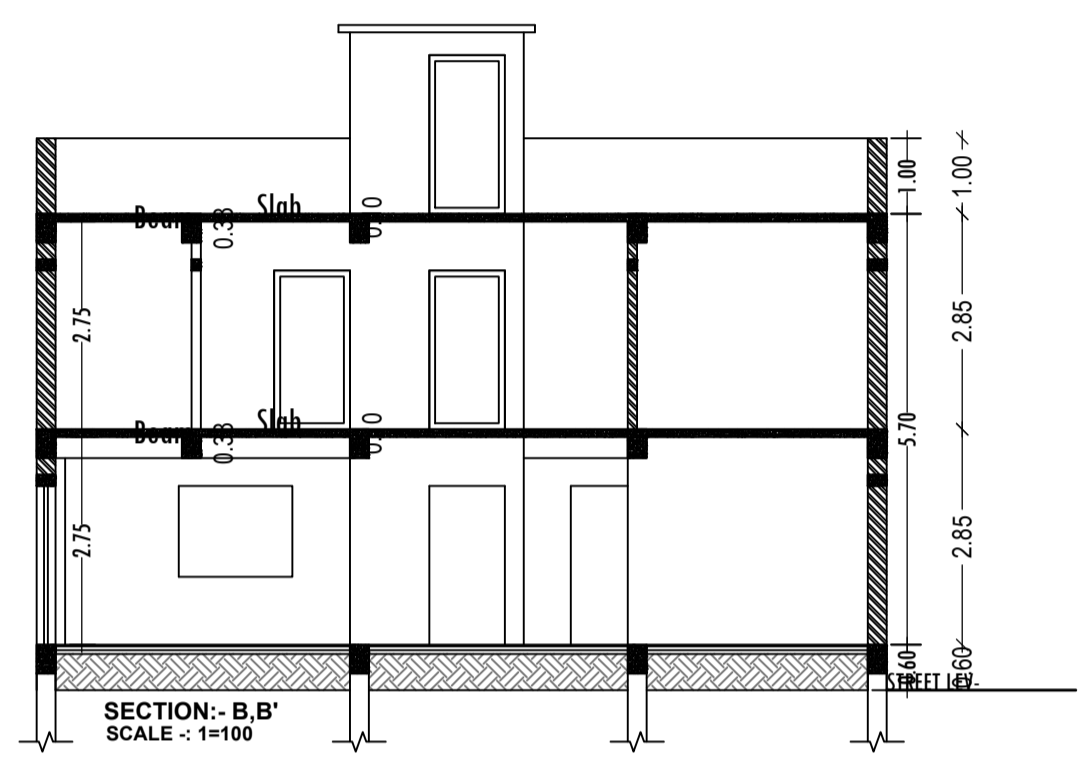

SECTION- B.B'
SCALE :- 1=100

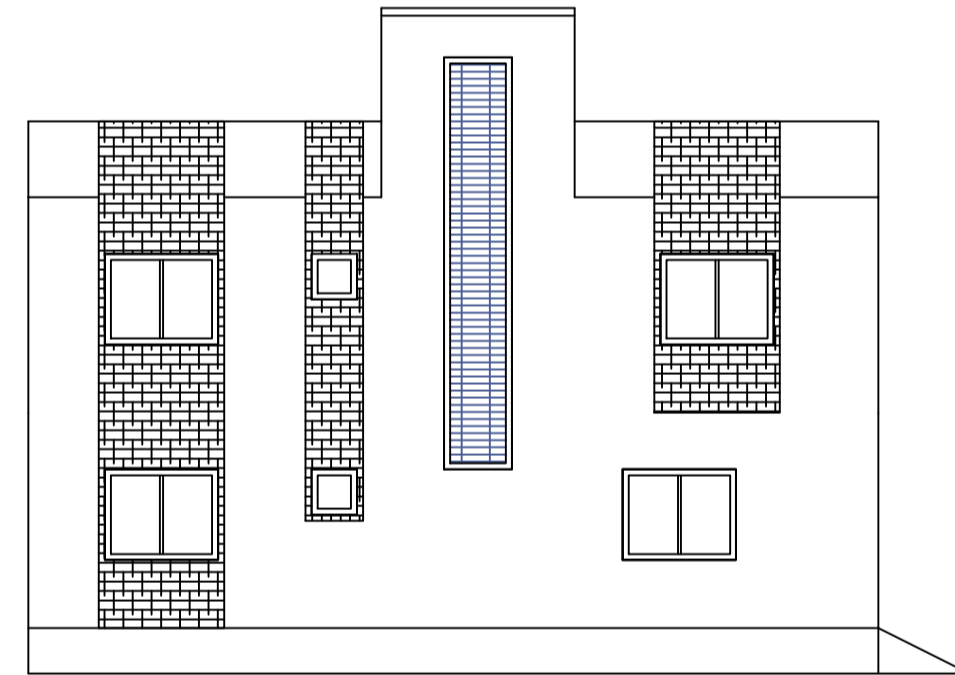

SIDE ELEVATION
SCALE :- 1=100

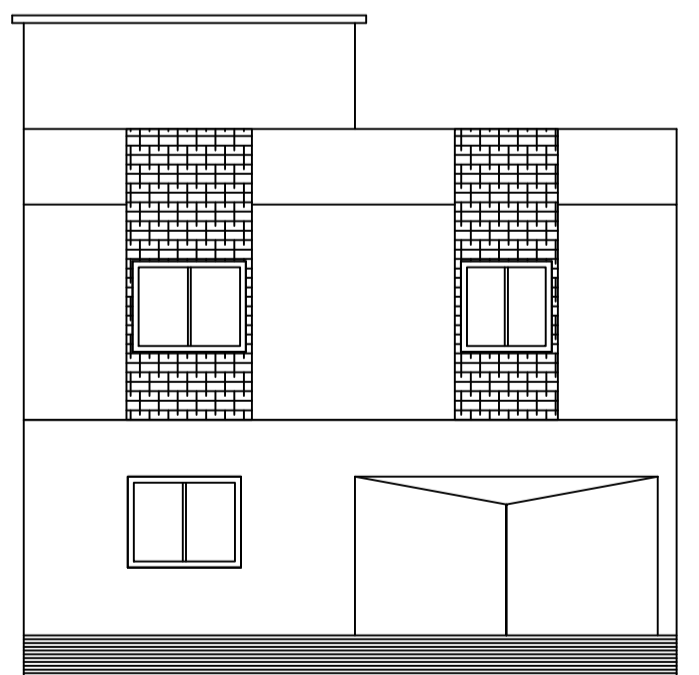

FRONT ELEVATION
SCALE :- 1=100

COLOR INDEX

PLOT BOUNDARY	Black
ABUTTING ROAD	Red
PROPOSED CONSTRUCTION	Green
COMMON PLOT	Yellow
ROAD WIDENING AREA	Blue
EXISTING (To be retained)	Orange
EXISTING (To be demolished)	Light Blue

Buildingwise Floor FAR Details

Floor Name	Building Name		Total	
	Proposed Built Up Area (Sq.mt.)	Proposed FAR Area (Sq.mt.)	Total Proposed Built Up Area (Sq.mt.)	Total FAR Area (Sq.mt.)
Ground Floor	97.13	97.13	97.13	97.13
First Floor	97.13	97.13	97.13	97.13
Terrace Floor	0.00	0.00	0.00	0.00
Total :	194.26	194.26	194.26	194.26

Building USE/SUBUSE Details

Building Name	Building Use	Building SubUse	Building Structure
AA (SMT ANGELA SINGH)	Residential	Bungalow/ Dwelling / Non Apartment	Non-Highrise

LTP NAME AND SIGNATURE	STRUCTURAL ENG'S NAME AND SIGNATURE	BUILDER NAME AND SIGNATURE	DIGITAL SIGNATURE
MD SHOAB ALAM JNP/ENG/001/2017			