

SITE PLAN
SCALE :- 1=100

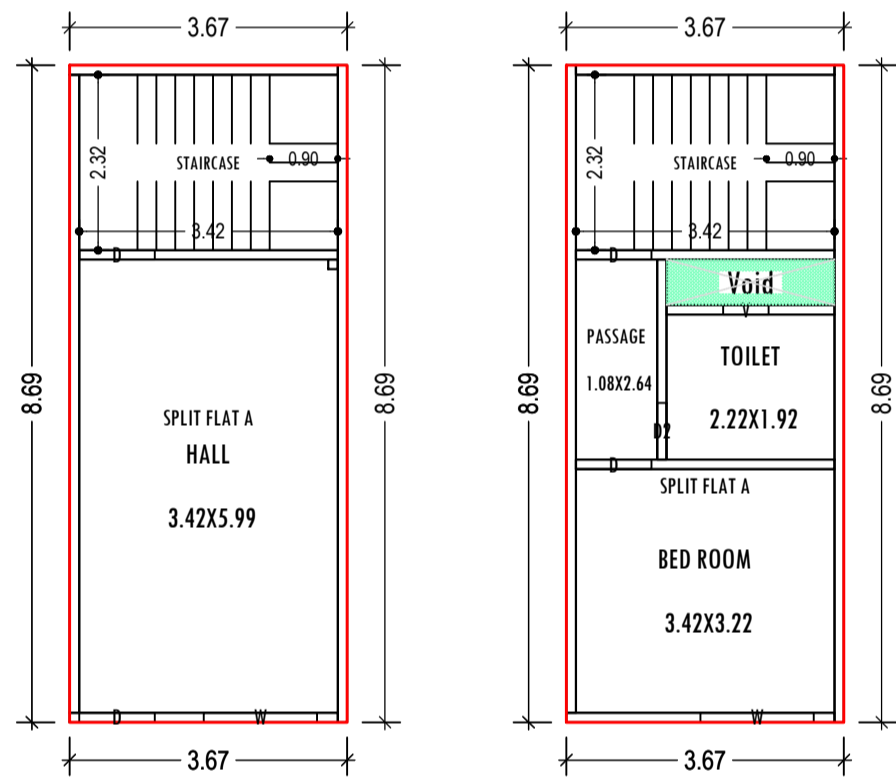

GROUND FLOOR PLAN
(Proposed)
SCALE 1:100

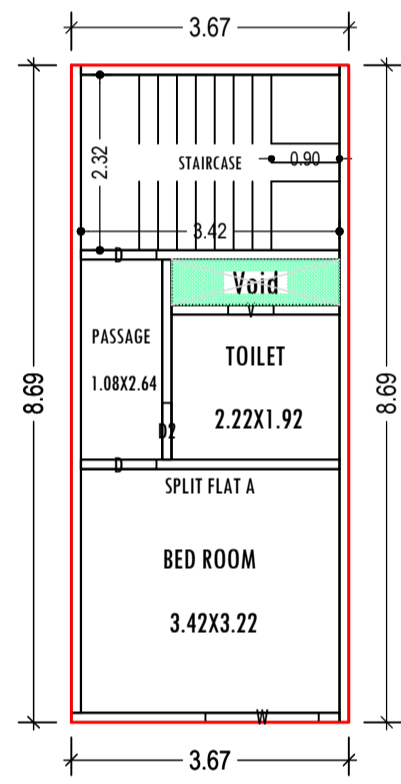

FIRST FLOOR PLAN
(Proposed)
SCALE 1:100

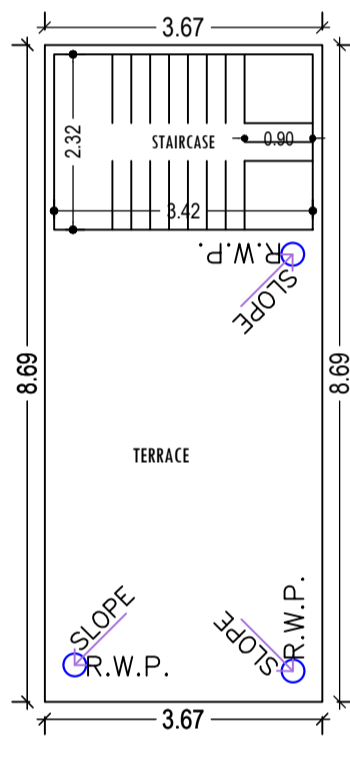

TERRACE FLOOR PLAN
(SCALE 1:100)

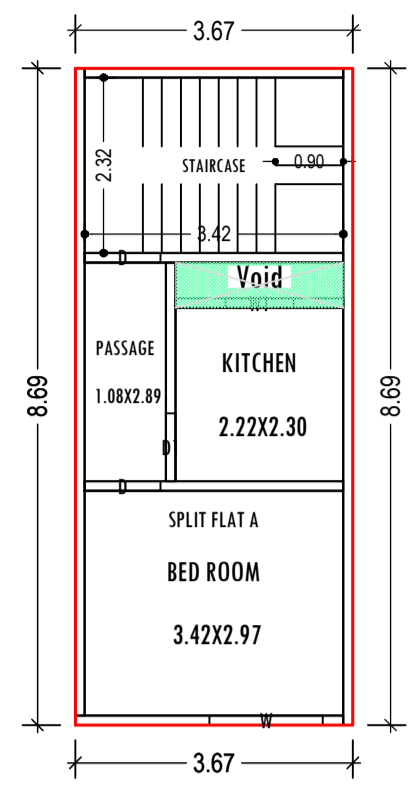

SECOND FLOOR PLAN
(Proposed)
SCALE 1:100

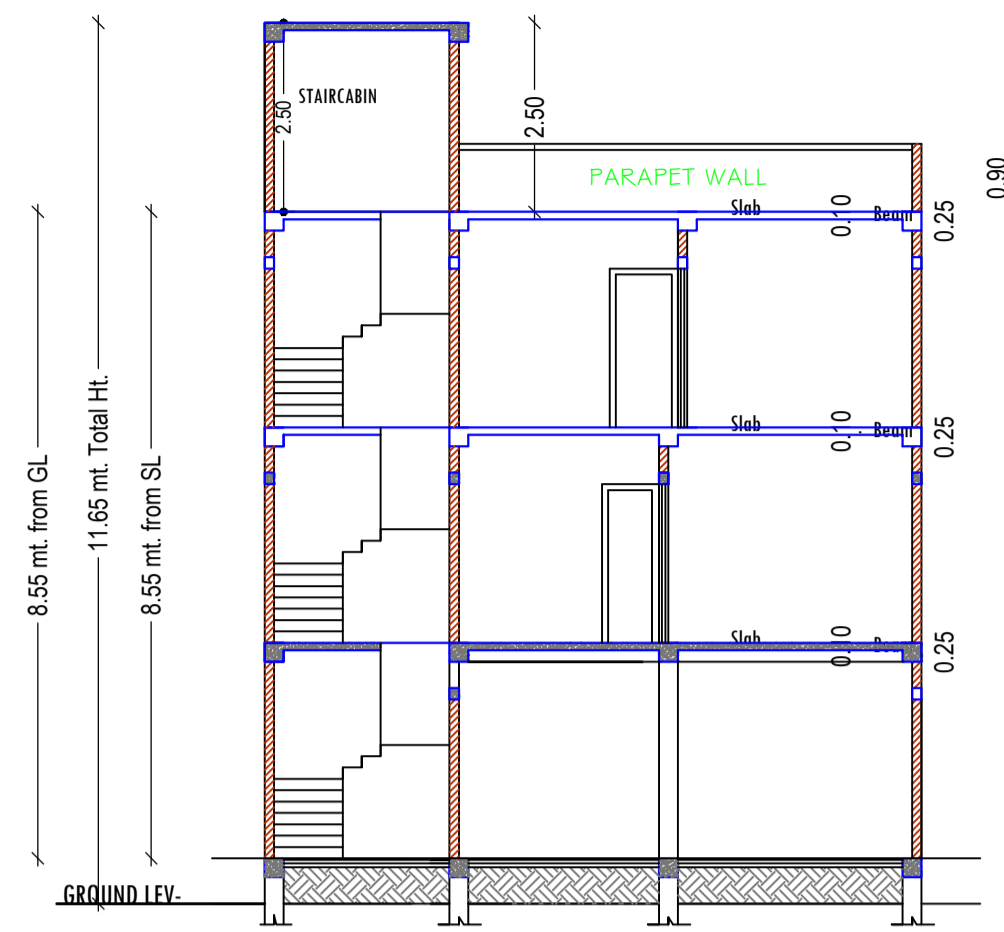

SECTION:- X,X
SCALE :- 1=100

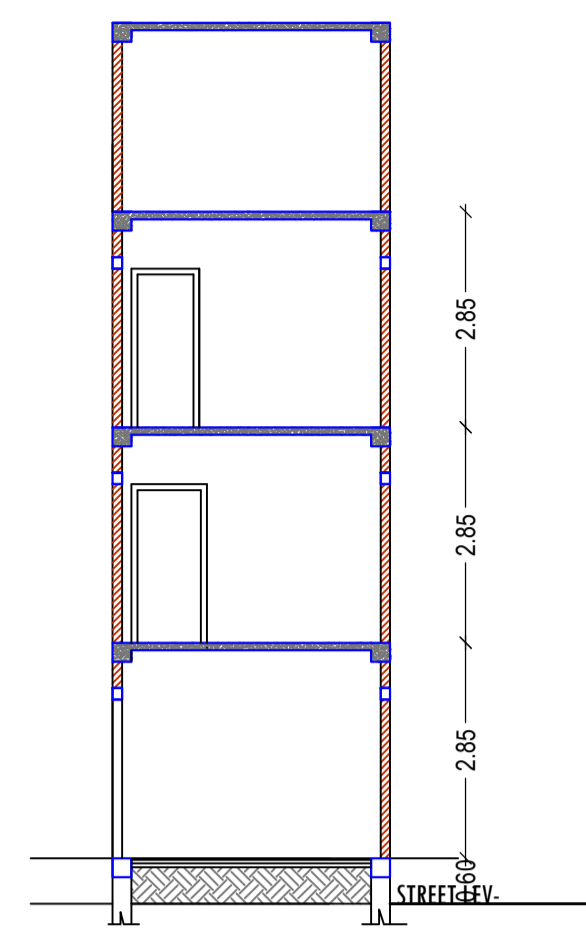

SECTION:- Y,Y
SCALE :- 1=100

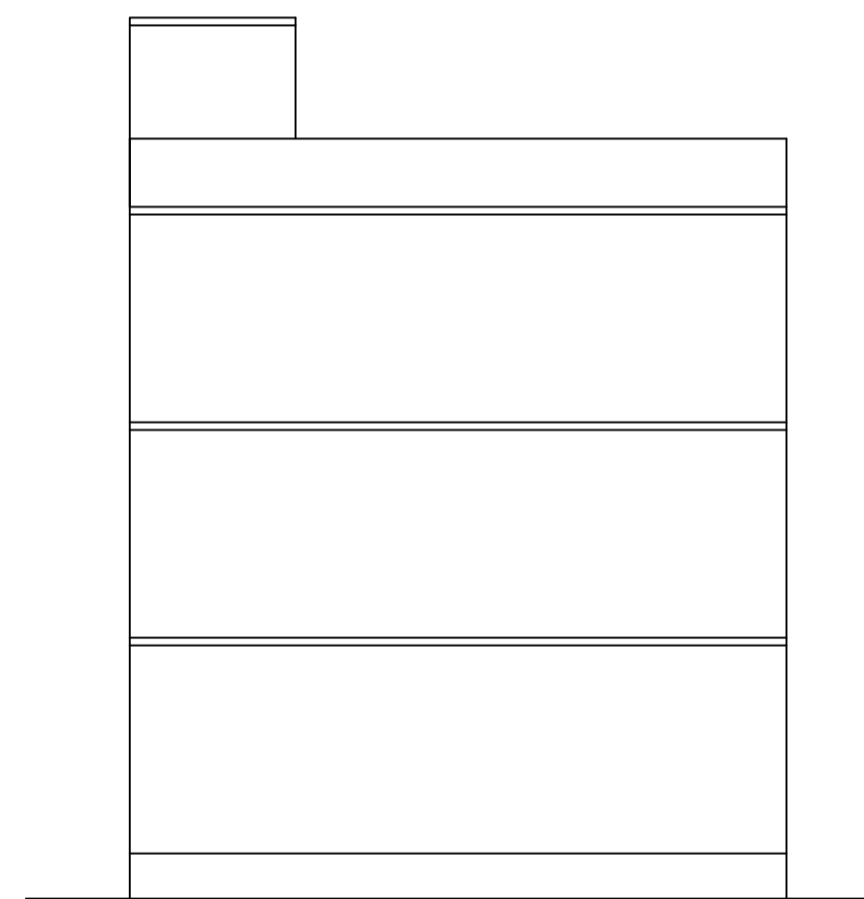

WEST SIDE ELEVATION
SCALE :- 1=100

FAR & Tenement Details (Table 4c-1)

Building	No. of Same Bldg	Total Built Up Area (Sq.mt.)	Deductions (Area in Sq.mt.)	Proposed FAR Area (Sq.mt.)	Total FAR Area (Sq.mt.)	Total Consumed Additional FAR Area (Sq.mt.)	Tnmt (No.)
AA (SRI RAJ KUMAR CHHABRA)	1	95.67	2.66	93.01	93.01	93.01	01
Grand Total :	1	95.67	2.66	93.01	93.01	93.01	01

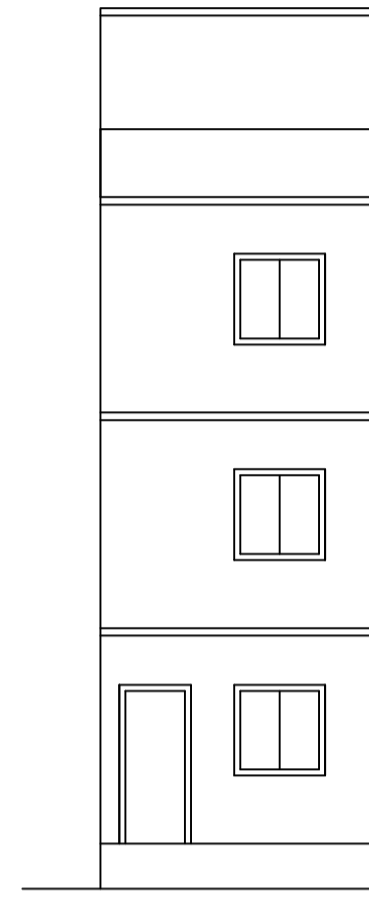

FRONT ELEVATION
SCALE :- 1=100

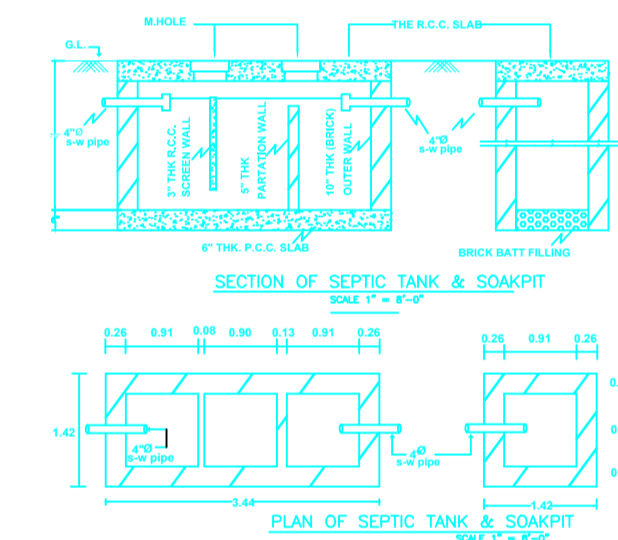

Proposal Basic Information

Proposal File No.	JNP/IBP/0098/W12/2022
Owner Name	SRI RAJ KUMAR CHHABRA
Khata No	440
Plot No	7287,7288
Village Name	Tilaiya
Use	Residential
SubUse	Bungalow/ Dwelling / Non Apartment

AREA STATEMENT		VERSION NO. :- 1.0.64
JHUMRITILAIYA NAGAR PARISHAD		VERSION DATE: 16/10/2020
PROJECT DETAIL:		
Region: JHARKHAND URBAN LOCAL BODIES	Plot Use: Residential	
District: KODERMA	Plot SubUse: Bungalow/ Dwelling / Non Apartment	
Authority: JHUMRITILAIYA NAGAR PARISHAD	PlotNearby/ReligiousStructure: NA	
Inward No: JNP/IBP/0098/W12/2022	PlotSubPlot No: 7287,7288	
Application Type: General Proposal	North: Plot No. - LAND OF MANJEET SINGH	
Project Type: Building Permission	South: Road Width - 6.10M WIDE ROAD	
Nature of Development: New	East: Plot No. - OWN LAND OF VENDER	
Location of Development Area: Old Area	West: Plot No. - OWN LAND OF VENDER	
AREA DETAILS:		
AREA OF PLOT (Minimum)	(A)	SQ.MT. 55.71
NET AREA OF PLOT(Gross Plot Area - Deduction from Gross Plot area)	(A-Deductions)	55.71
Deduction for Balance Plot Area(from Gross Plot Area)		
Common Plot		5.01
Total		5.01
BALANCE AREA OF PLOT(Net Plot Area - Recreational/Amenity space)	(A-Deductions)	50.70
PLOT AREA FOR COVERAGE(Net Plot Area)	(A-Deductions)	55.71
Plot Area for FAR (Net Plot Area + RoadWidening Area)	(A-Deductions)	55.71
COVERAGE CHECK		
Permissible Coverage area (70.00 %)		39.00
Proposed Coverage Area (57.25 %)		31.89
Total Prop. Coverage Area (57.25 %)		31.89
Balance coverage area (12.76 %)		7.11
FAR CHECK		
Perm. FAR Area (2.00)		111.42
Incentive FAR Area (2.000)		111.42
Perm. FAR Area (4.000)		222.84
Total Perm. FAR area		222.84
Residential FAR		93.00
Proposed FAR Area		93.00
Total Proposed FAR Area		93.00
Consumed FAR (Factor)		1.67
Balance FAR Area		129.84
BUILT UP AREA CHECK		
Total Proposed BuiltUp Area		95.67
ARCHITECT (Regd)	MD SHOAB ALAM	
ENGINEER (Regd)		
SUPERVISOR (Regd)		
OWNER (Regd)	SRI RAJ KUMAR CHHABRA	
DEVELOPMENT AUTHORITY		LOCAL BODY

COLOR INDEX	
PLOT BOUNDARY	Black
ABUTTING ROAD	Green
PROPOSED CONSTRUCTION	Red
COMMON PLOT	Yellow
ROAD WIDENING AREA	Blue
EXISTING (To be retained)	Light Blue
EXISTING (To be demolished)	Light Yellow

Building :AA (SRI RAJ KUMAR CHHABRA)							
Floor Name	Total Built Up Area (Sq.mt.)	Deductions (Area in Sq.mt.)	Proposed FAR Area (Sq.mt.)	Total FAR Area (Sq.mt.)	Total Consumed Additional FAR Area (Sq.mt.)	Tnmt (No.)	
Ground Floor	31.89	0.00	31.89	31.89	31.89	01	
First Floor	31.89	1.33	30.56	30.56	30.56	00	
Second Floor	31.89	1.33	30.56	30.56	30.56	00	
Terrace Floor	0.00	0.00	0.00	0.00	0.00	00	
Total :	95.67	2.66	93.01	93.01	93.01	01	
Total Number of Same Buildings	1						
Total :	95.67	2.66	93.01	93.01	93.01	01	

SCHEDULE OF DOOR:

BUILDING NAME	NAME	LENGTH	HEIGHT	NOS
AA (SRI RAJ KUMAR CHHABRA)	D2	0.75	2.10	01
AA (SRI RAJ KUMAR CHHABRA)	D1	0.90	2.10	01
AA (SRI RAJ KUMAR CHHABRA)	D	1.00	2.10	06

SCHEDULE OF WINDOW/VENTILATION:

BUILDING NAME	NAME	LENGTH	HEIGHT	NOS
AA (SRI RAJ KUMAR CHHABRA)	V	0.60	0.60	01
AA (SRI RAJ KUMAR CHHABRA)	W1	0.90	1.20	01
AA (SRI RAJ KUMAR CHHABRA)	W	1.50	1.20	03

UnitBUA Table for Building :AA (SRI RAJ KUMAR CHHABRA)

FLOOR	Name	UnitBUA Type	UnitBUA Area	Carpet Area	No. of Rooms	No. of Tenement
GROUND FLOOR PLAN	SPLIT FLAT A	FLAT	58.83	56.71	1	1
FIRST FLOOR PLAN	SPLIT FLAT A	FLAT	0.00	0.00	3	0
SECOND FLOOR PLAN	SPLIT FLAT A	FLAT	0.00	0.00	3	0
Total:	-	-	58.83	56.71	7	1

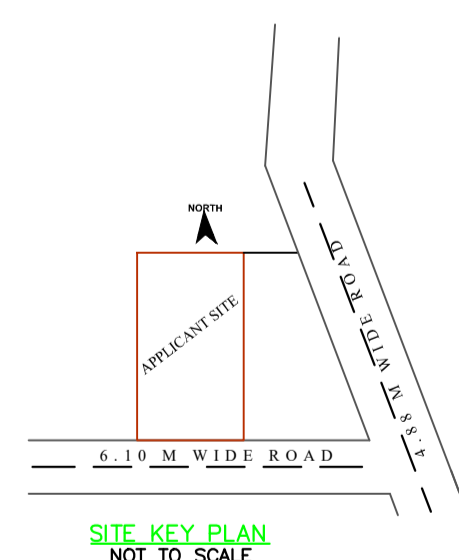

SITE KEY PLAN
NOT TO SCALE

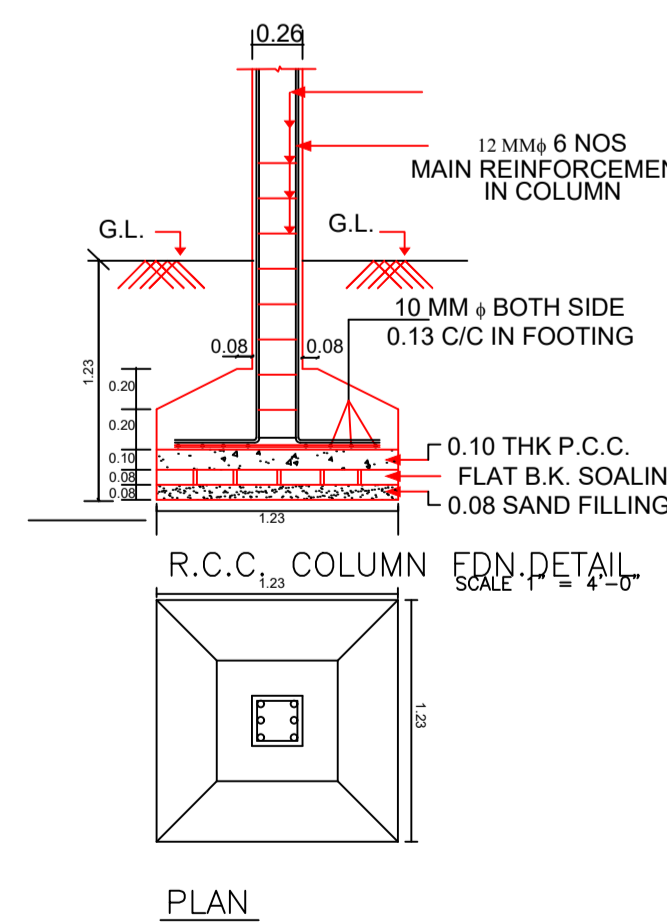

PLAN

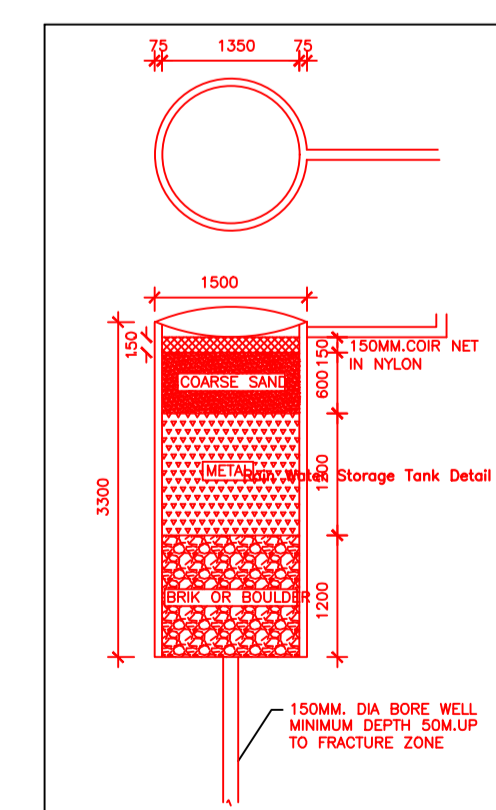

LTP NAME AND SIGNATURE	STRUCTURAL ENG'S NAME AND SIGNATURE	BUILDER NAME AND SIGNATURE	DIGITAL SIGNATURE
MD SHOAB ALAM JNP/ENG/0001/2017			