

SITE PLAN
SCALE :- 1=100

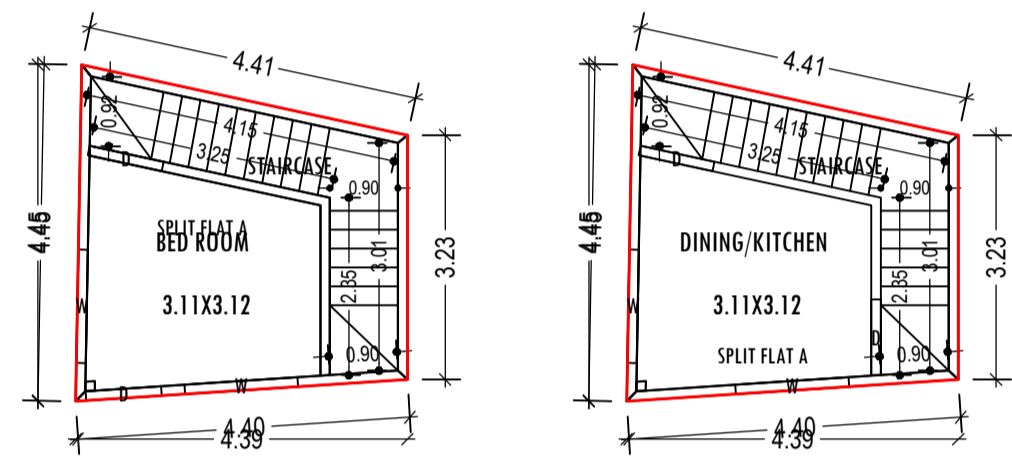

GROUND FLOOR PLAN
(Proposed)
SCALE 1:100

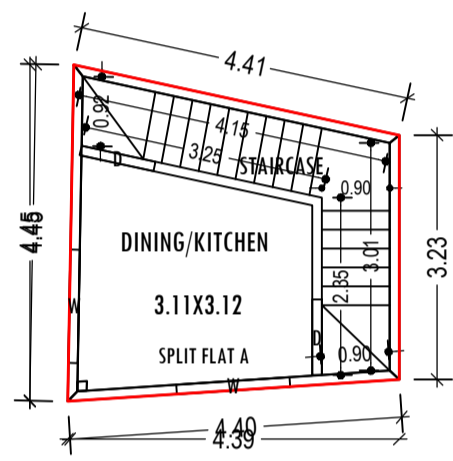

SECOND FLOOR PLAN
(Proposed)
SCALE 1:100

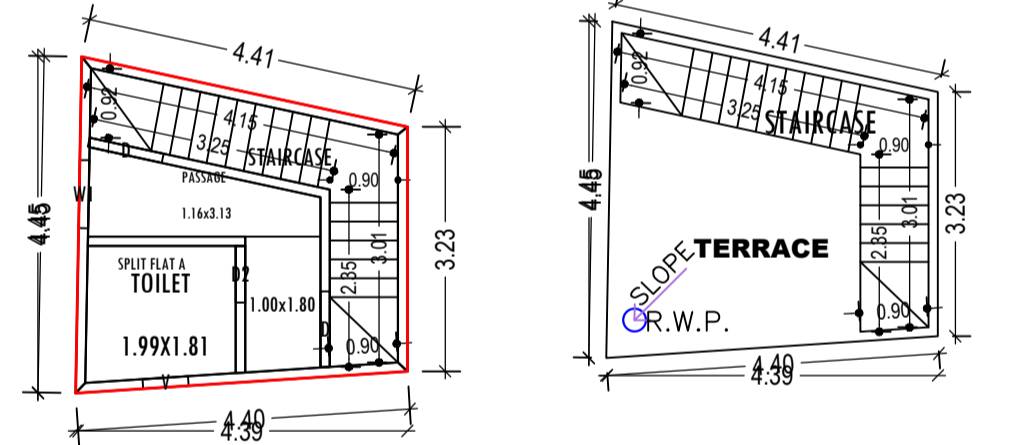

FIRST FLOOR PLAN
(Proposed)
SCALE 1:100

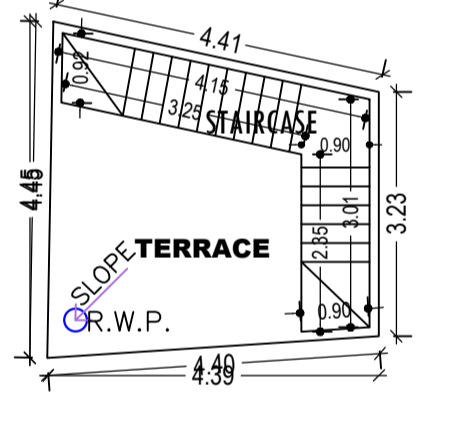

TERRACE FLOOR PLAN
(SCALE 1:100)

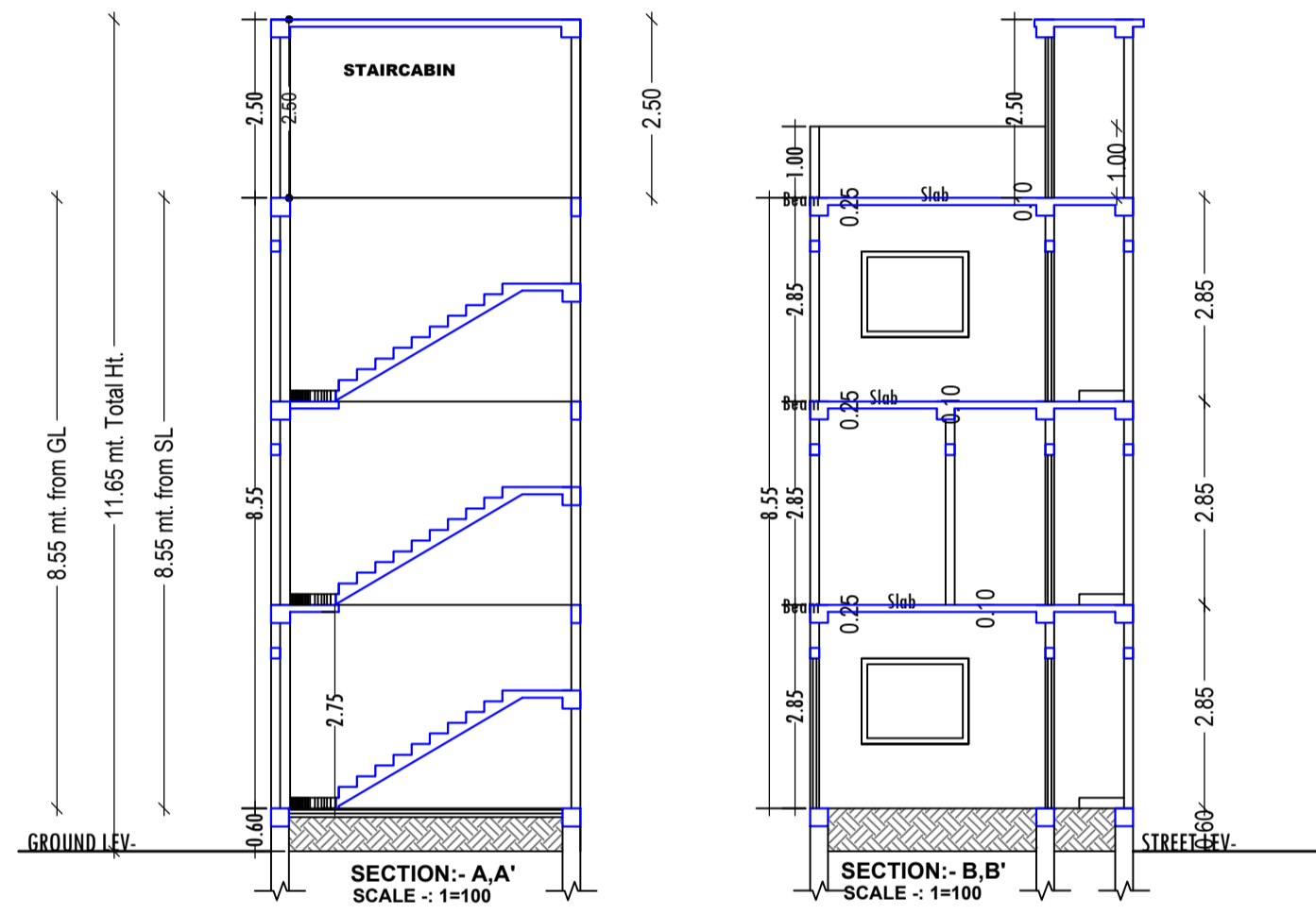

SECTION - A-A'
SCALE :- 1=100

SECTION - B-B'
SCALE :- 1=100

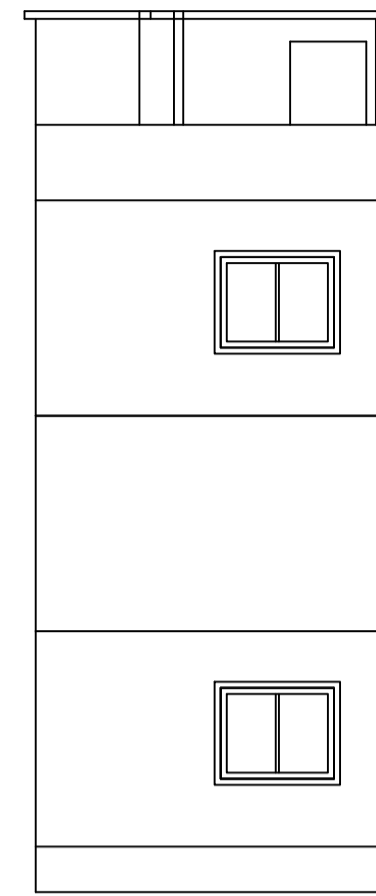

SIDE ELEVATION
SCALE :- 1=100

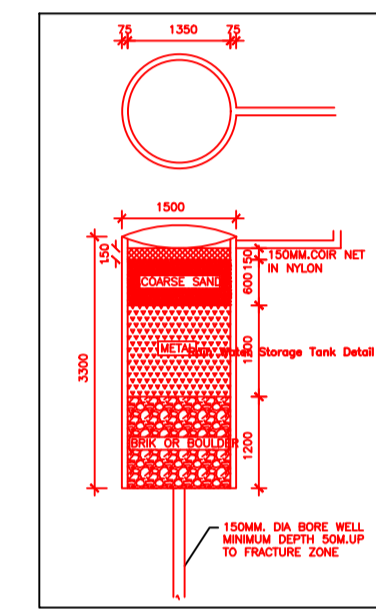

FAR & Tenement Details (Table 4c-1)

Building	No. of Same Bldg	Total Built Up Area (Sq.mt.)	Proposed FAR Area (Sq.mt.) Resi.	Total FAR Area (Sq.mt.)	Total Consumed Additional FAR Area (Sq.mt.)	Tnmt (No.)
AA (SRI DINESHWAR SINGH)	1	50.13	50.13	50.13	50.13	01
Grand Total :	1	50.13	50.13	50.13	50.13	01

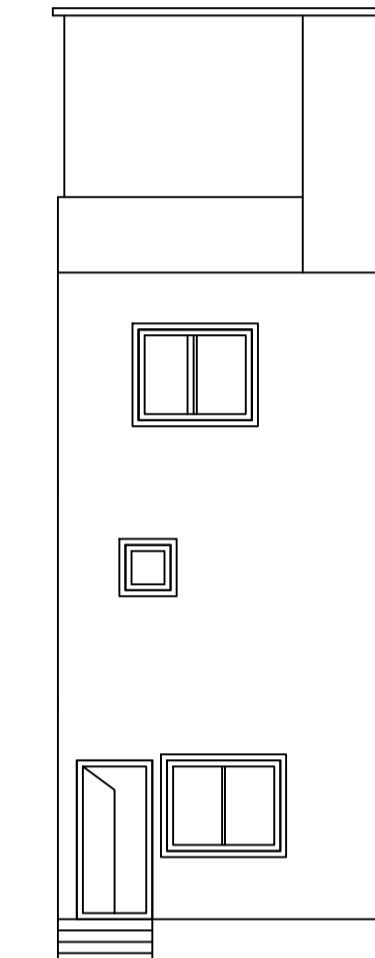

FRONT ELEVATION
SCALE :- 1=100

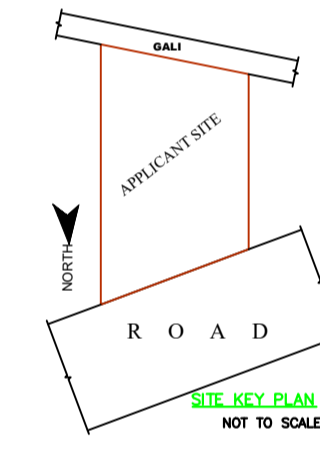

SITE KEY PLAN
NOT TO SCALE

AREA STATEMENT		SQ. MT.
AREA OF PLOT (Minimum)		(A)
NET AREA OF PLOT (Gross Plot Area - Deduction from Gross Plot area)		33.59
Deduction for Balance Plot Area (from Gross Plot Area)		
Common Plot		2.90
Total		2.90
BALANCE AREA OF PLOT (Net Plot Area - Recreational/Amenity space)		30.68
PLOT AREA FOR COVERAGE (Net Plot Area)		33.59
Plot Area for FAR (Net Plot Area + Road Widening Area)		33.59
COVERAGE CHECK		
Permissible Coverage area (70.00 %)		23.51
Proposed Coverage Area (49.75 %)		16.71
Total Prop. Coverage Area (49.75 %)		16.71
Balance coverage area (20.24 %)		6.80
FAR CHECK		
Perm. FAR Area (1.80)		60.46
Incentive FAR Area (1.800)		60.46
Perm. FAR Area (3.600)		120.92
Total Perm. FAR area		120.92
Residential FAR		50.14
Proposed FAR Area		50.14
Total Proposed FAR Area		50.14
Consumed FAR (Factor)		1.49
Balance FAR Area		70.78
BUILT UP AREA CHECK		
Total Proposed BuiltUp Area		50.13
ARCHITECT (Regd)		MD SHOAB ALAM
ENGINEER (Regd)		
SUPERVISOR (Regd)		
OWNER (Regd)		SRI DINESHWAR SINGH
DEVELOPMENT AUTHORITY		LOCAL BODY

COLOR INDEX	
PLOT BOUNDARY	Black
ABUTTING ROAD	Red
PROPOSED CONSTRUCTION	Green
COMMON PLOT	Yellow
ROAD WIDENING AREA	Blue
EXISTING (To be retained)	Orange
EXISTING (To be demolished)	Pink

Building -AA (SRI DINESHWAR SINGH)						
Floor Name	Total Built Up Area (Sq.mt.)	Proposed FAR Area (Sq.mt.) Resi.	Total FAR Area (Sq.mt.)	Total Consumed Additional FAR Area (Sq.mt.)	Tnmt (No.)	
Ground Floor	16.71	16.71	16.71	16.71	01	
First Floor	16.71	16.71	16.71	16.71	00	
Second Floor	16.71	16.71	16.71	16.71	00	
Terrace Floor	0.00	0.00	0.00	0.00	00	
Total :	50.13	50.13	50.13	50.13	01	
Total Number of Same Buildings : 1						
Total :	50.13	50.13	50.13	50.13	01	

SCHEDULE OF DOOR:

BUILDING NAME	NAME	LENGTH	HEIGHT	NOS
AA (SRI DINESHWAR SINGH)	D2	0.75	2.10	01
AA (SRI DINESHWAR SINGH)	D	1.00	2.10	06

SCHEDULE OF WINDOW/VENTILATION:

BUILDING NAME	NAME	LENGTH	HEIGHT	NOS
AA (SRI DINESHWAR SINGH)	V	0.60	0.60	01
AA (SRI DINESHWAR SINGH)	W1	0.90	1.20	01
AA (SRI DINESHWAR SINGH)	W	1.50	1.20	04

UnitBUA Table for Building -AA (SRI DINESHWAR SINGH)

FLOOR	Name	UnitBUA Type	UnitBUA Area	Carpet Area	No. of Rooms	No. of Tenement
GROUND FLOOR PLAN	SPLIT FLAT A	FLAT	24.85	24.35	1	1
FIRST FLOOR PLAN	SPLIT FLAT A	FLAT	0.00	0.00	2	0
SECOND FLOOR PLAN	SPLIT FLAT A	FLAT	0.00	0.00	1	0
Total:	-	-	24.85	24.35	4	1

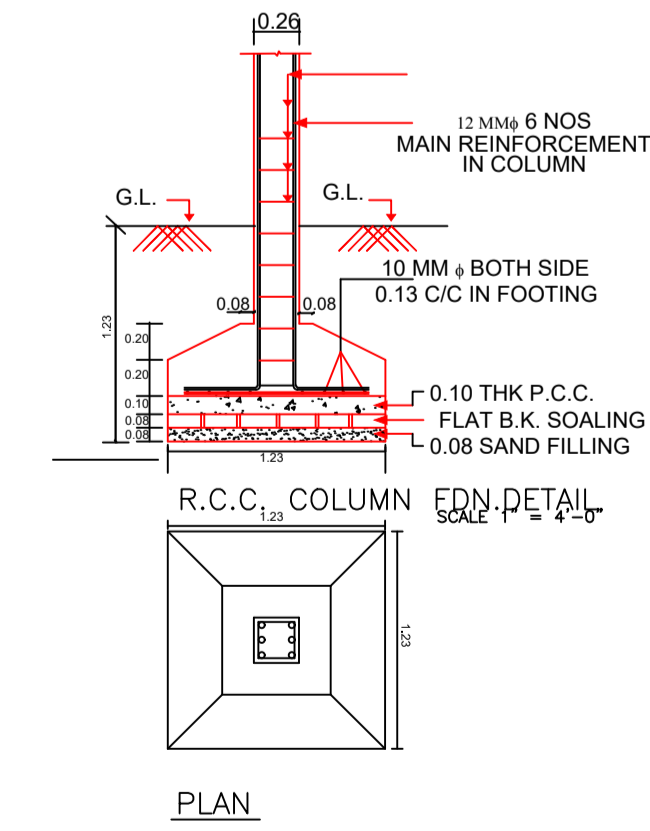
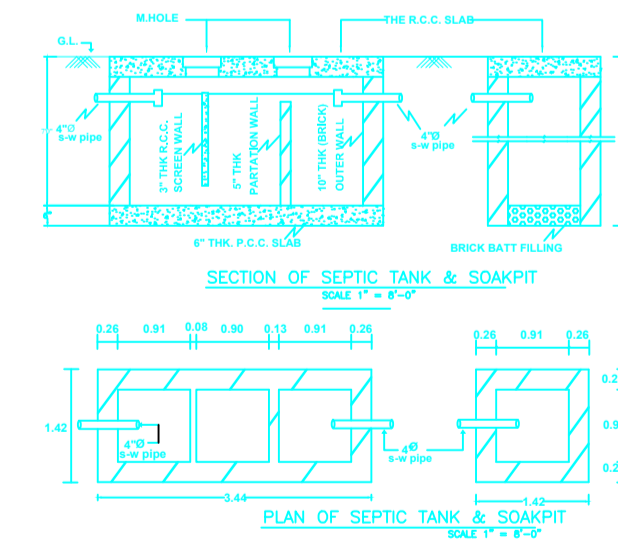

PLAN

Buildingwise Floor FAR Details

Floor Name	Building Name AA (SRI DINESHWAR SINGH)		Total	
	Proposed Built Up Area (Sq.mt.)	Proposed FAR Area (Sq.mt.)	Total Proposed Built Up Area (Sq.mt.)	Total FAR Area (Sq.mt.)
Ground Floor	16.71	16.71	16.71	16.71
First Floor	16.71	16.71	16.71	16.71
Second Floor	16.71	16.71	16.71	16.71
Terrace Floor	0.00	0.00	0.00	0.00
Total :	50.13	50.13	50.13	50.13

Building USE/SUBUSE Details

Building Name	Building Use	Building SubUse	Building Structure
AA (SRI DINESHWAR SINGH)	Residential	Bungalow/ Dwelling / Non Apartment	Non-Highrise

LTP NAME AND SIGNATURE	STRUCTURAL ENG'S NAME AND SIGNATURE	BUILDER NAME AND SIGNATURE	DIGITAL SIGNATURE
MD SHOAB ALAM JNP/ENG/001/2017			