

SITE PLAN

SCALE :- 1=100

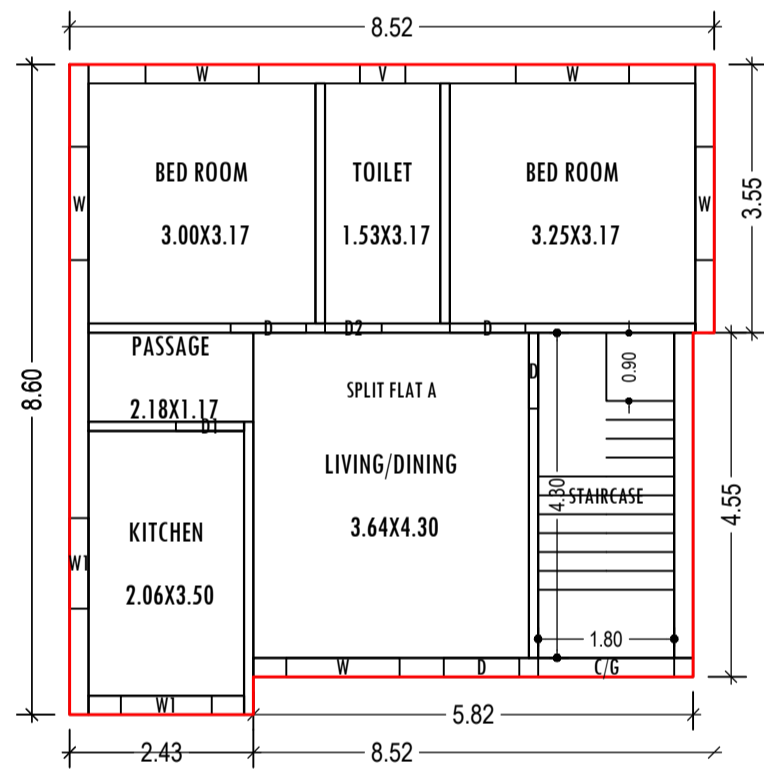

GROUND FLOOR PLAN (Proposed) (SCALE 1:100)

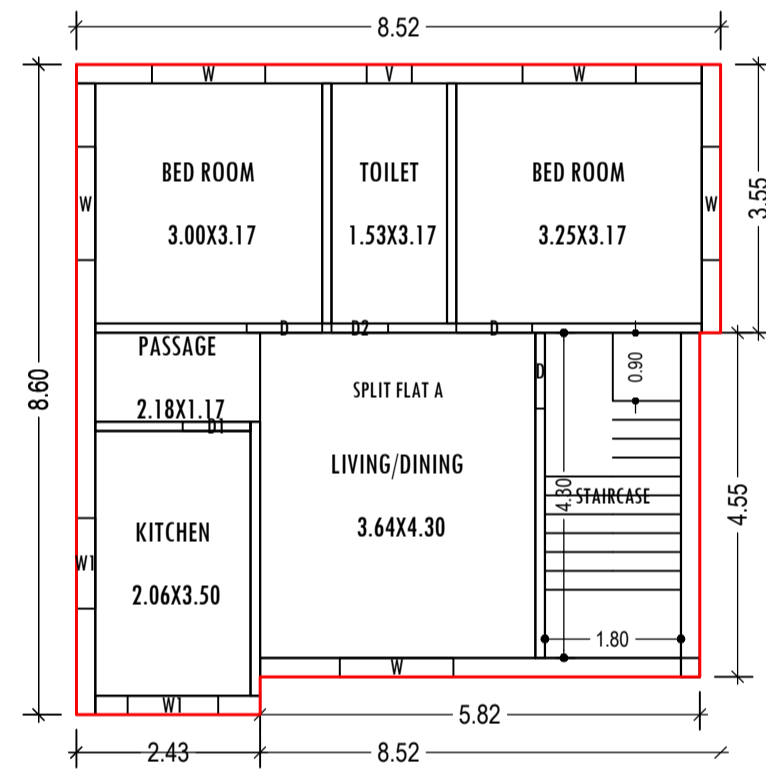

FIRST FLOOR PLAN (Proposed) (SCALE 1:100)

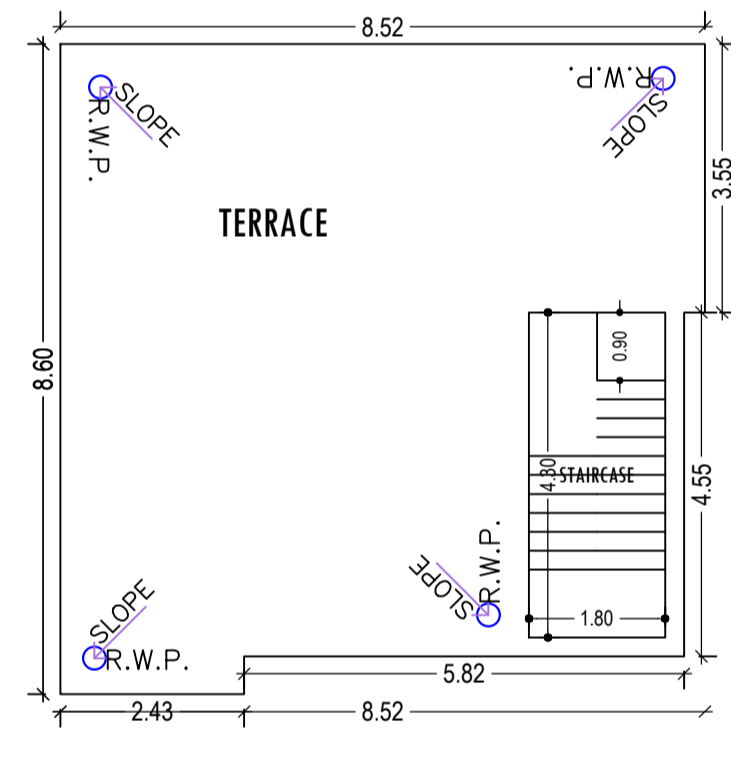

TERRACE FLOOR PLAN (SCALE 1:100)

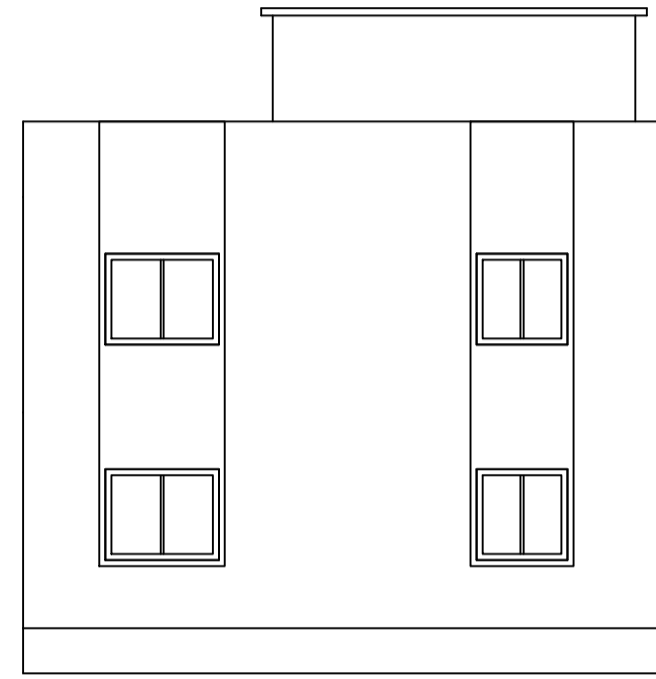

SIDE ELEVATION SCALE :- 1=100

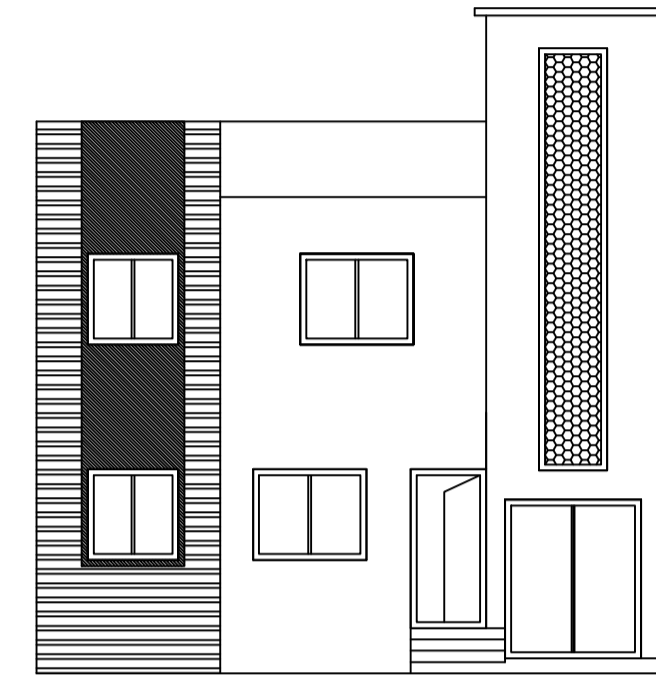

FRONT ELEVATION SCALE :- 1=100

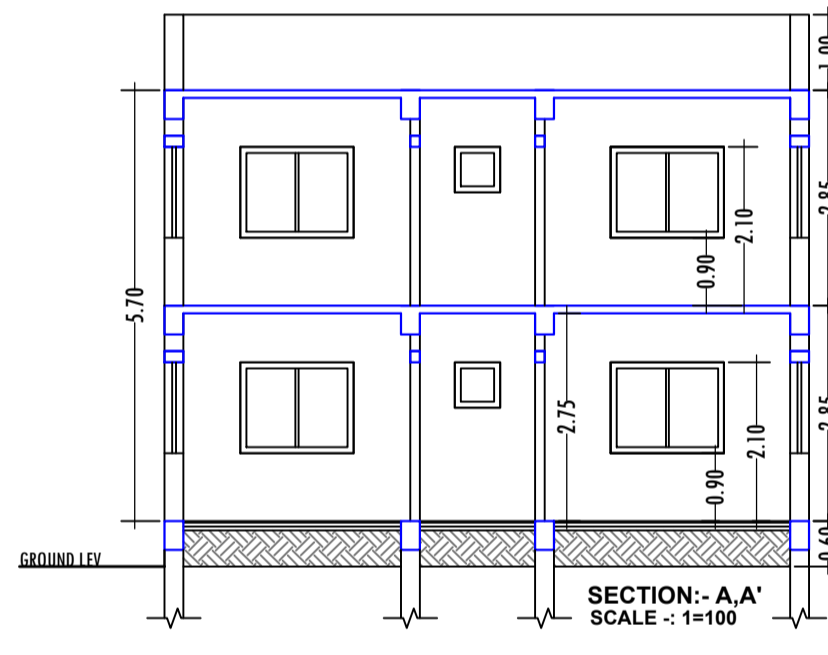

SECTION:- A, A' SCALE :- 1=100

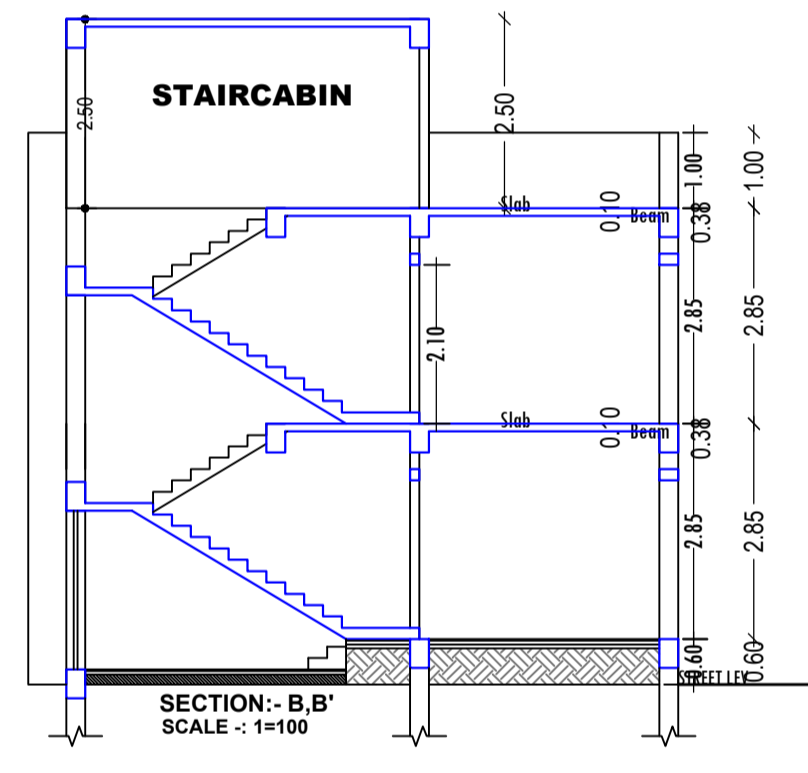

SECTION:- B, B' SCALE :- 1=100

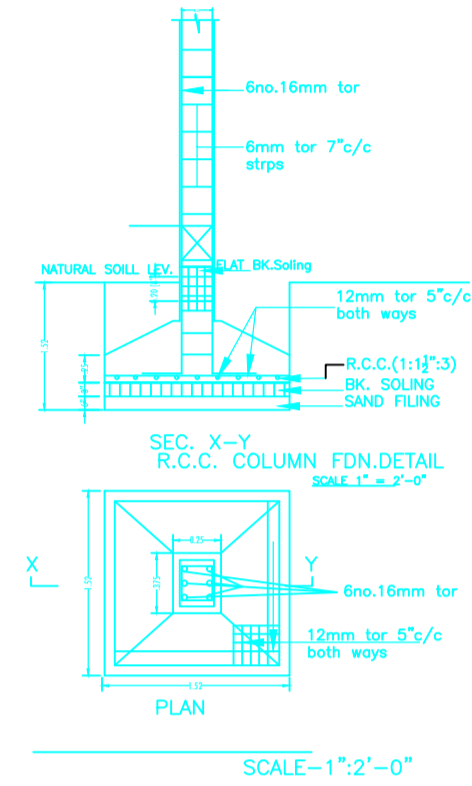

SCALE=1"=2'-0"

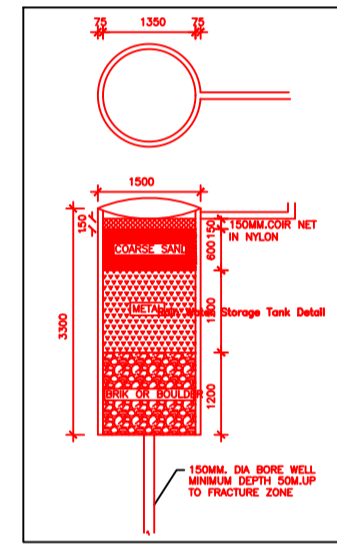

FAR & Tenement Details (Table 4c-1)

Building	No. of Same Bldg	Total Built Up Area (Sq.mt.)	Proposed FAR Area (Sq.mt.) Resi.	Total FAR Area (Sq.mt.)	Total Consumed Additional FAR Area (Sq.mt.)	Tnmt (No.)
AA (SRI NANDKISHOR)	1	137.96	137.96	137.96	137.96	01
Grand Total :	1	137.96	137.96	137.96	137.96	01

Proposal Basic Information

Proposal File No.	JNP/IBP/0110/W22/2022
Owner Name	SRI NANDKISHOR
Khata No	355
Plot No	1065
Village Name	Gomo
Use	Residential
SubUse	Bungalow/ Dwelling / Non Apartment

AREA STATEMENT	VERSION NO. : 1.0.64
JHUMRITLAIYA NAGAR PARISHAD	VERSION DATE: 16/10/2020
PROJECT DETAIL:	
Region: JHARKHAND URBAN LOCAL BODIES	Plot Use: Residential
District: KODERMA	Plot SubUse: Bungalow/ Dwelling / Non Apartment
Authority: JHUMRITLAIYA NAGAR PARISHAD	PlotNearbyReligiousStructure: NA
Inward No: JNP/IBP/0110/W22/2022	Plot/SubPlot No: 1065
Application Type: General Proposal	North: Plot No. - ABDUL RAHIM
Project Type: Building Permission	South: Plot No. - NU VENDOR (MEHRUN KHATOON)
Nature of Development: New	East: Road Width - 0.91M WIDE RASTA
Location of Development Area: Old Area	West: Plot No. - SEKH SAMSUDDIN
AREA DETAILS:	
AREA OF PLOT (Minimum)	(A) 153.47
Deduction for NetPlot Area	
Road Widening Area	27.40
Total	126.07
NET AREA OF PLOT(Gross Plot Area - Deduction from Gross Plot area)	(A-Deductions) 126.07
Deduction for Balance Plot Area(from Gross Plot Area)	
Road Widening Area	27.40
Common Plot	12.97
Total	40.37
BALANCE AREA OF PLOT(Net Plot Area - Recreational/Amenity space)	(A-Deductions) 113.10
PLOT AREA FOR COVERAGE(Net Plot Area)	(A-Deductions) 126.07
Plot Area for FAR (Net Plot Area + RoadWidening Area)	(A-Deductions) 126.07
COVERAGE CHECK	
Permissible Coverage area ( 70.00 % )	88.25
Proposed Coverage Area ( 54.72 % )	68.98
Total Prop. Coverage Area ( 54.72 % )	68.98
Balance coverage area ( 15.29 % )	19.27
FAR CHECK	
Perm. FAR Area ( 1.20 )	151.28
Incentive FAR Area ( 1.200 )	151.29
Perm. FAR Area ( 2.400 )	302.57
Total Perm. FAR Area	302.57
Residential FAR	137.96
Proposed FAR Area	137.96
Total Proposed FAR Area	137.96
Consumed FAR (Factor)	1.09
Balance FAR Area	164.61
BUILT UP AREA CHECK	
Total Proposed BuiltUp Area	137.96
ARCHITECT (Regd)	MD SHOAB ALAM
ENGINEER (Regd)	
SUPERVISOR (Regd)	
OWNER (Regd)	SRI NANDKISHOR
DEVELOPMENT AUTHORITY	LOCAL BODY

Floor Name	Total Built Up Area (Sq.mt.)	Proposed FAR Area (Sq.mt.) Resi.	Total FAR Area (Sq.mt.)	Total Consumed Additional FAR Area (Sq.mt.)	Tnmt (No.)
Ground Floor	68.98	68.98	68.98	68.98	01
First Floor	68.98	68.98	68.98	68.98	00
Terrace Floor	0.00	0.00	0.00	0.00	00
Total :	137.96	137.96	137.96	137.96	01
Total Number of Same Buildings	1				
Total :	137.96	137.96	137.96	137.96	01

SCHEDULE OF DOOR:

BUILDING NAME	NAME	LENGTH	HEIGHT	NOS
AA (SRI NANDKISHOR)	D2	0.75	2.10	02
AA (SRI NANDKISHOR)	D1	0.90	2.10	02
AA (SRI NANDKISHOR)	D	1.00	2.10	07

SCHEDULE OF WINDOW/VENTILATION:

BUILDING NAME	NAME	LENGTH	HEIGHT	NOS
AA (SRI NANDKISHOR)	V	0.60	0.60	02
AA (SRI NANDKISHOR)	W1	1.20	1.20	04
AA (SRI NANDKISHOR)	W	1.50	1.20	10

UnitBUA Table for Building :AA (SRI NANDKISHOR)

FLOOR	Name	UnitBUA Type	UnitBUA Area	Carpet Area	No. of Rooms	No. of Tenement
GROUND FLOOR PLAN	SPLIT FLAT A	FLAT	104.50	102.40	6	1
FIRST FLOOR PLAN	SPLIT FLAT A	FLAT	0.00	0.00	6	0
Total:	-	-	104.50	102.40	12	1

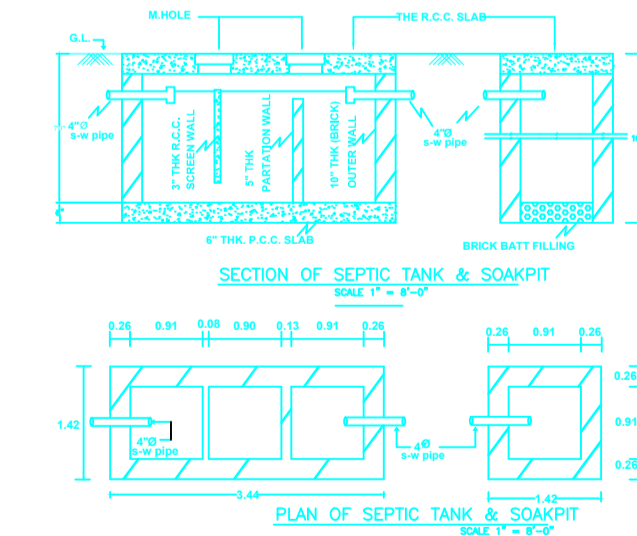
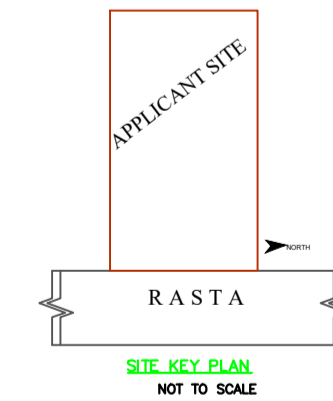

Buildingwise Floor FAR Details

Floor Name	Building Name AA (SRI NANDKISHOR)		Total	
	Proposed Built Up Area (Sq.mt.)	Proposed FAR Area (Sq.mt.)	Total Proposed Built Up Area (Sq.mt.)	Total FAR Area (Sq.mt.)
Ground Floor	68.98	68.98	68.98	68.98
First Floor	68.98	68.98	68.98	68.98
Terrace Floor	0.00	0.00	0.00	0.00
Total :	137.96	137.96	137.96	137.96

Building USE/SUBUSE Details

Building Name	Building Use	Building SubUse	Building Structure
AA (SRI NANDKISHOR)	Residential	Bungalow/ Dwelling / Non Apartment	Non-Highrise

LTP NAME AND SIGNATURE MD SHOAB ALAM JNP/ENG/0001/2017	STRUCTURAL ENG'S NAME AND SIGNATURE	BUILDER NAME AND SIGNATURE	DIGITAL SIGNATURE
--	-------------------------------------	----------------------------	-------------------