

SITE PLAN
SCALE :- 1=100

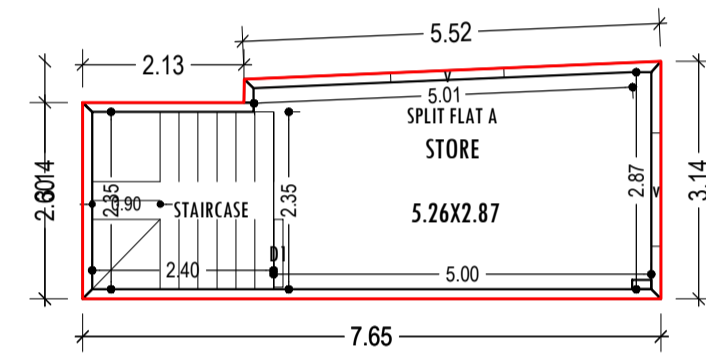

BASEMENT FLOOR PLAN
(Proposed)
SCALE 1:100

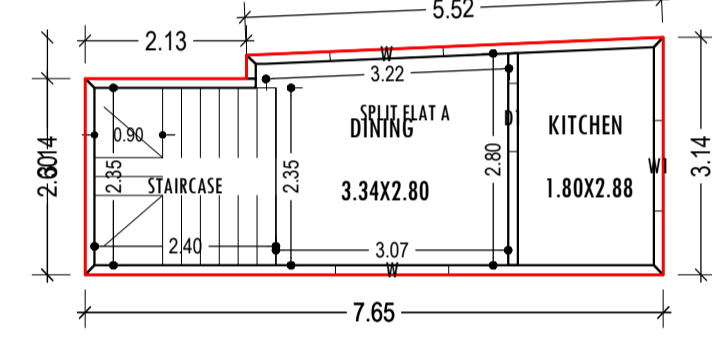

SECOND FLOOR PLAN
(Proposed)
SCALE 1:100

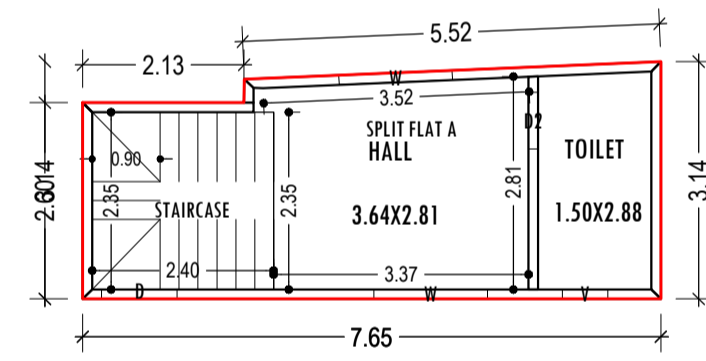

GROUND FLOOR PLAN
(Proposed)
SCALE 1:100

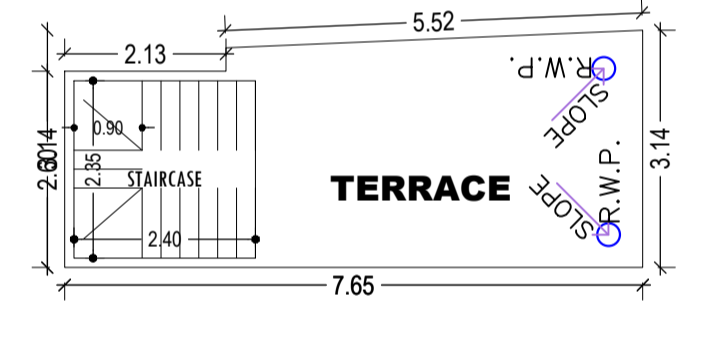

TERRACE FLOOR PLAN
(Proposed)
SCALE 1:100

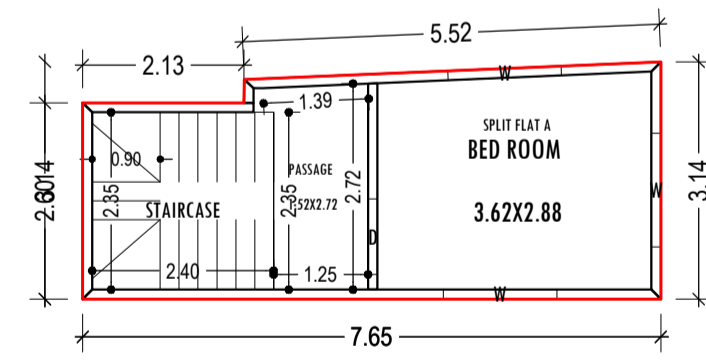

FIRST FLOOR PLAN
(Proposed)
SCALE 1:100

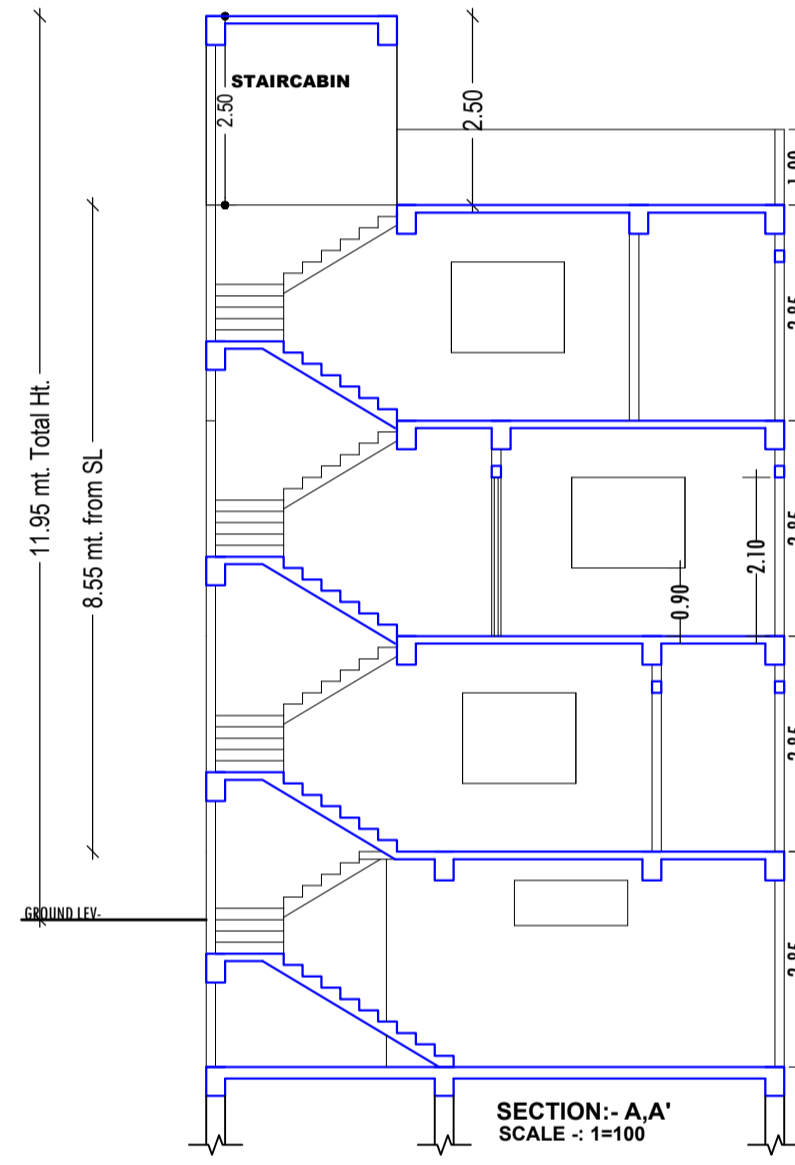

SECTION:- A.A'
SCALE :- 1=100

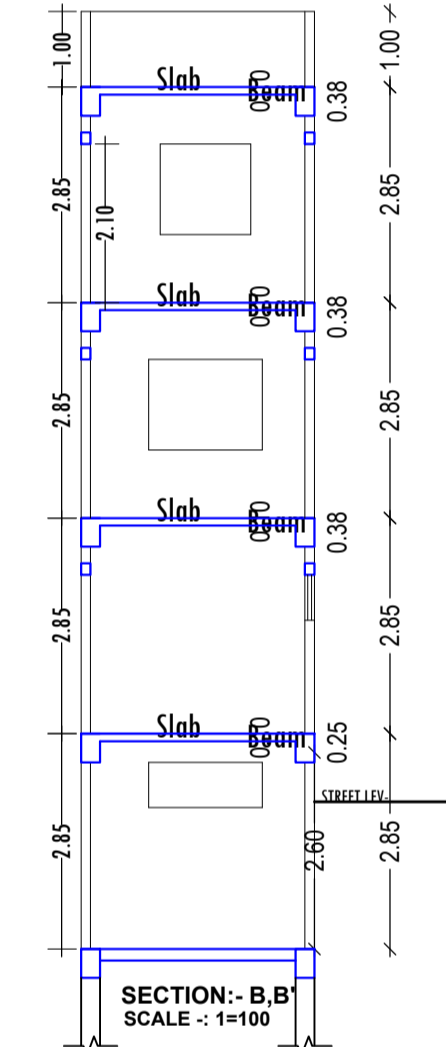

SECTION:- B.B'
SCALE :- 1=100

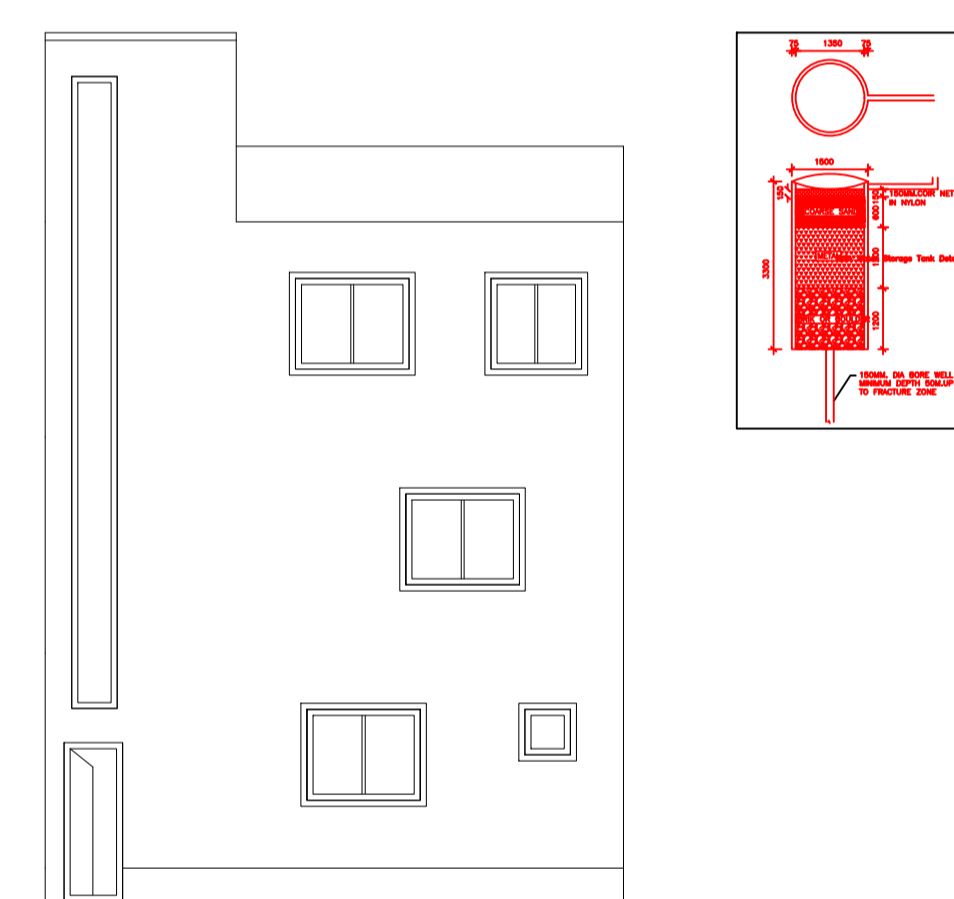
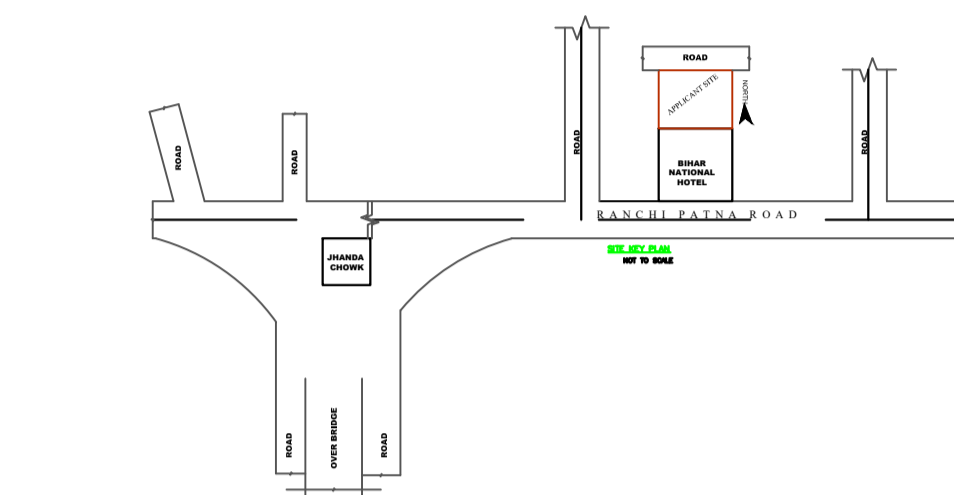

FRONT ELEVATION
SCALE :- 1=100

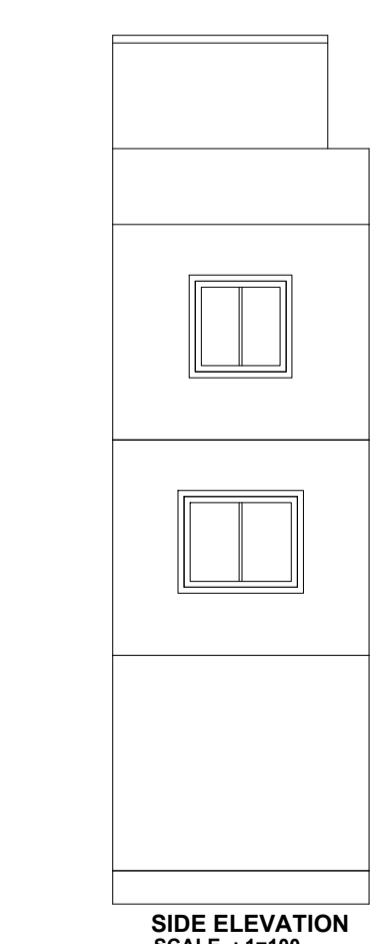

SIDE ELEVATION
SCALE :- 1=100

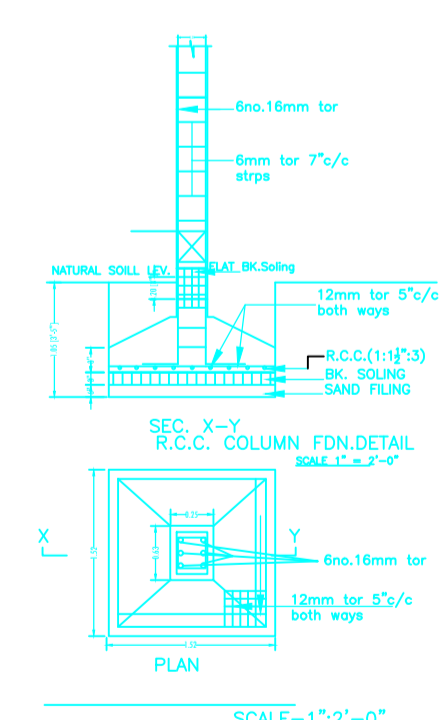

SCALE :- 1"=2'-0"

FAR & Tenement Details (Table 4c-1)

Building	No. of Same Bldg	Total Built Up Area (Sq.mt.)	Proposed FAR Area (Sq.mt.) Resi.	Total FAR Area (Sq.mt.)	Total Consumed Additional FAR Area (Sq.mt.)	Tnmt (No.)
AA (MALTI DEVI)	1	88.80	88.80	88.80	88.80	01
Grand Total :	1	88.80	88.80	88.80	88.80	01

Proposal Basic Information

Proposal File No.	JNP/BB/0120/W12/2022
Owner Name	MALTI DEVI
Khata No	1152
Plot No	7411
Village Name	Tilaiya
Use	Residential
SubUse	Bungalow/ Dwelling / Non Apartment

AREA STATEMENT		VERSION NO. : 1.0.65
PROJECT DETAIL:		VERSION DATE: 16/10/2020
Region: JHARKHAND URBAN LOCAL BODIES	Plot Use: Residential	
District: KODERMA	Plot SubUse: Bungalow/ Dwelling / Non Apartment	
Authority: JHUMRITILAIYA NAGAR PARISHAD	Plot/NearbyReligiousStructure: NA	
Inward No.: JNP/BB/0120/W12/2022	Plot/SubPlot No: 7411	
Application Type: General Proposal	North: Road Width - 3.66M WIDE ROSD	
Project Type: Building Permission	South: Plot No. - SHIV SHANKAR PRASAD	
Nature of Development: New	East: Plot No. - JEETENDERA PATEL & DURGA MISTRI	
Location of Development Area: Old Area	West: Plot No. - SHIV PRASAD VISWAKARMA & RAM JEE PRASAD	
AREA DETAILS:		SQ. MT.
AREA OF PLOT (Minimum)	(A)	66.49
NET AREA OF PLOT(Gross Plot Area - Deduction from Gross Plot area)	(A-Deductions)	66.49
Deduction for Balance Plot Area(from Gross Plot Area)		
Common Plot		6.90
Total		6.90
BALANCE AREA OF PLOT(Net Plot Area - Recreational/Amenity space)	(A-Deductions)	59.58
PLOT AREA FOR COVERAGE(Net Plot Area)	(A-Deductions)	66.49
Plot Area for FAR (Net Plot Area + Road Widening Area)	(A-Deductions)	66.49
COVERAGE CHECK		
Permissible Coverage area (70.00 %)		46.54
Proposed Coverage Area (33.39 %)		22.20
Total Prop. Coverage Area (33.39 %)		22.20
Balance coverage area (36.61 %)		24.34
FAR CHECK		
Perm. FAR Area (1.500)		99.74
Total Perm. FAR area		99.74
Residential FAR		88.80
Proposed FAR Area		88.80
Total Proposed FAR Area		88.80
Consumed FAR (Factor)		1.34
Balance FAR Area		10.94
BUILT UP AREA CHECK		
Total Proposed BuiltUp Area		88.80
ARCHITECT (Regd)		MD SHOAIB ALAM
ENGINEER (Regd)		
SUPERVISOR (Regd)		
OWNER (Regd)		MALTI DEVI
DEVELOPMENT AUTHORITY		LOCAL BODY

COLOR INDEX	
PLOT BOUNDARY	Black
ABUTTING ROAD	Green
PROPOSED CONSTRUCTION	Red
COMMON PLOT	Yellow
ROAD WIDENING AREA	Blue
EXISTING (To be retained)	Light Blue
EXISTING (To be demolished)	Dark Blue

Building -AA (MALTI DEVI)

Floor Name	Total Built Up Area (Sq.mt.)	Proposed FAR Area (Sq.mt.) Resi.	Total FAR Area (Sq.mt.)	Total Consumed Additional FAR Area (Sq.mt.)	Tnmt (No.)
Basement Floor	22.20	22.20	22.20	22.20	01
Ground Floor	22.20	22.20	22.20	22.20	00
First Floor	22.20	22.20	22.20	22.20	00
Second Floor	22.20	22.20	22.20	22.20	00
Terrace Floor	0.00	0.00	0.00	0.00	00
Total :	88.80	88.80	88.80	88.80	01
Total Number of Same Buildings	1				
Total :	88.80	88.80	88.80	88.80	01

SCHEDULE OF DOOR:

BUILDING NAME	NAME	LENGTH	HEIGHT	NOS
AA (MALTI DEVI)	D2	0.75	2.10	01
AA (MALTI DEVI)	D1	0.90	2.10	02
AA (MALTI DEVI)	D	1.00	2.10	01

SCHEDULE OF WINDOW/VENTILATION:

BUILDING NAME	NAME	LENGTH	HEIGHT	NOS
AA (MALTI DEVI)	V	0.60	0.60	01
AA (MALTI DEVI)	W1	1.20	1.20	01
AA (MALTI DEVI)	v	1.50	0.19	02
AA (MALTI DEVI)	W	1.50	1.20	07

UnitBUA Table for Building -AA (MALTI DEVI)

FLOOR	Name	UnitBUA Type	UnitBUA Area	Carpet Area	No. of Rooms	No. of Tenement
BASEMENT FLOOR PLAN	SPLIT FLAT A	FLAT	55.85	54.78	1	1
GROUND FLOOR PLAN	SPLIT FLAT A	FLAT	0.00	0.00	2	0
FIRST FLOOR PLAN	SPLIT FLAT A	FLAT	0.00	0.00	2	0
SECOND FLOOR PLAN	SPLIT FLAT A	FLAT	0.00	0.00	2	0
Total:	-	-	55.85	54.78	7	1

Buildingwise Floor FAR Details

Floor Name	Building Name AA (MALTI DEVI)		Total	
	Proposed Built Up Area (Sq.mt.)	Proposed FAR Area (Sq.mt.)	Total Proposed Built Up Area (Sq.mt.)	Total FAR Area (Sq.mt.)
Basement Floor	22.20	22.20	22.20	22.20
Ground Floor	22.20	22.20	22.20	22.20
First Floor	22.20	22.20	22.20	22.20
Second Floor	22.20	22.20	22.20	22.20
Terrace Floor	0.00	0.00	0.00	0.00
Total :	88.80	88.80	88.80	88.80

Building USE/SUBUSE Details

Building Name	Building Use	Building SubUse	Building Structure
AA (MALTI DEVI)	Residential	Bungalow/ Dwelling / Non Apartment	Non-Highrise

LTP NAME AND SIGNATURE	STRUCTURAL ENG'S NAME AND SIGNATURE	BUILDER NAME AND SIGNATURE	DIGITAL SIGNATURE
MD SHOAIB ALAM JNP/ENG/0001/2017			