

SITE PLAN SCALE:- 1:100

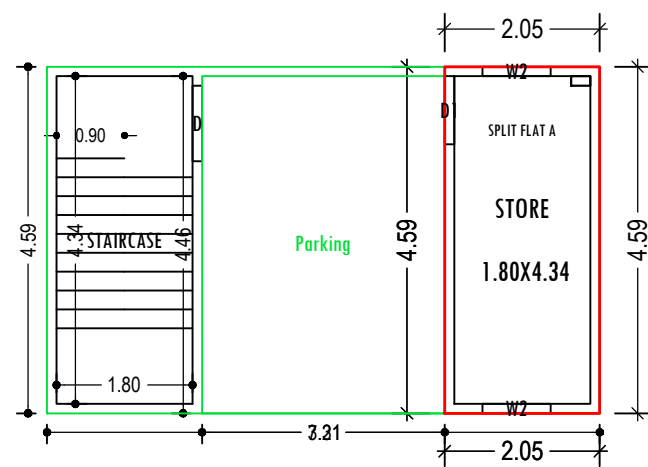

GROUND FLOOR PLAN (Proposed) SCALE 1:100

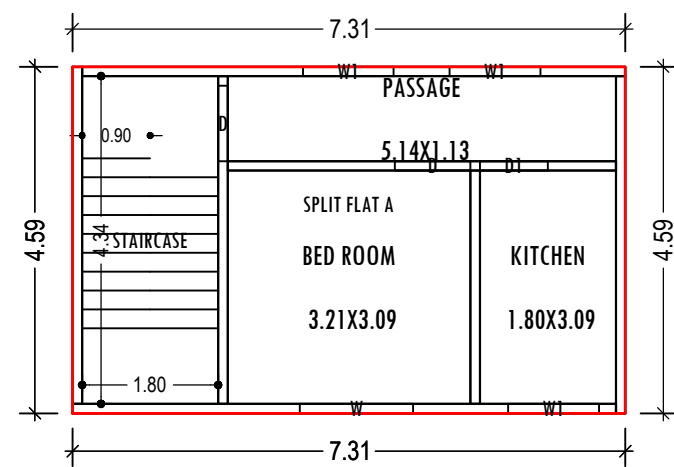

SECOND FLOOR PLAN (Proposed) SCALE 1:100

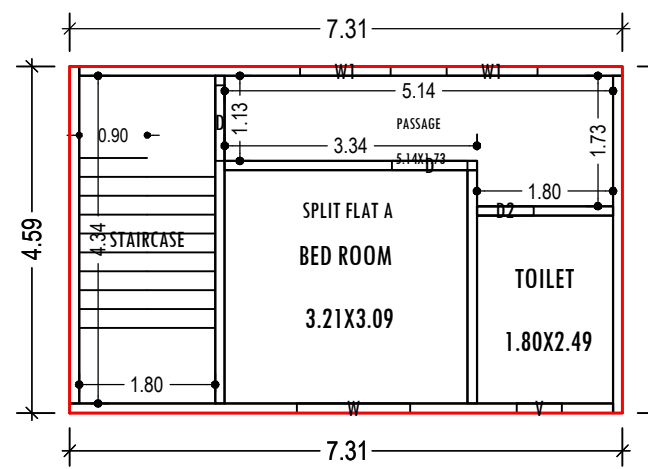

FIRST FLOOR PLAN (Proposed) SCALE 1:100

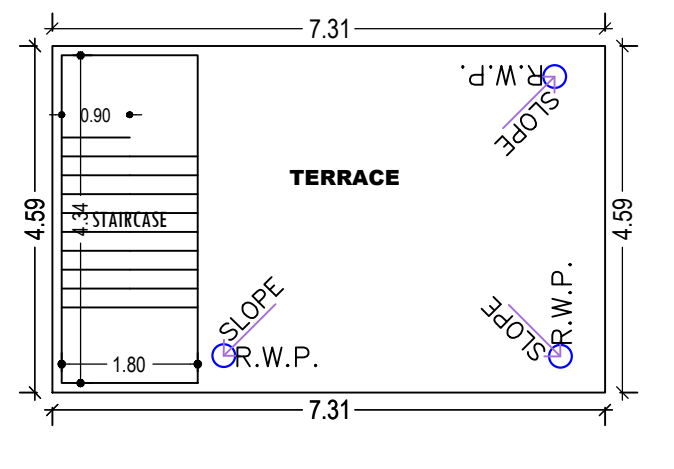

TERRACE FLOOR PLAN (SCALE 1:100)

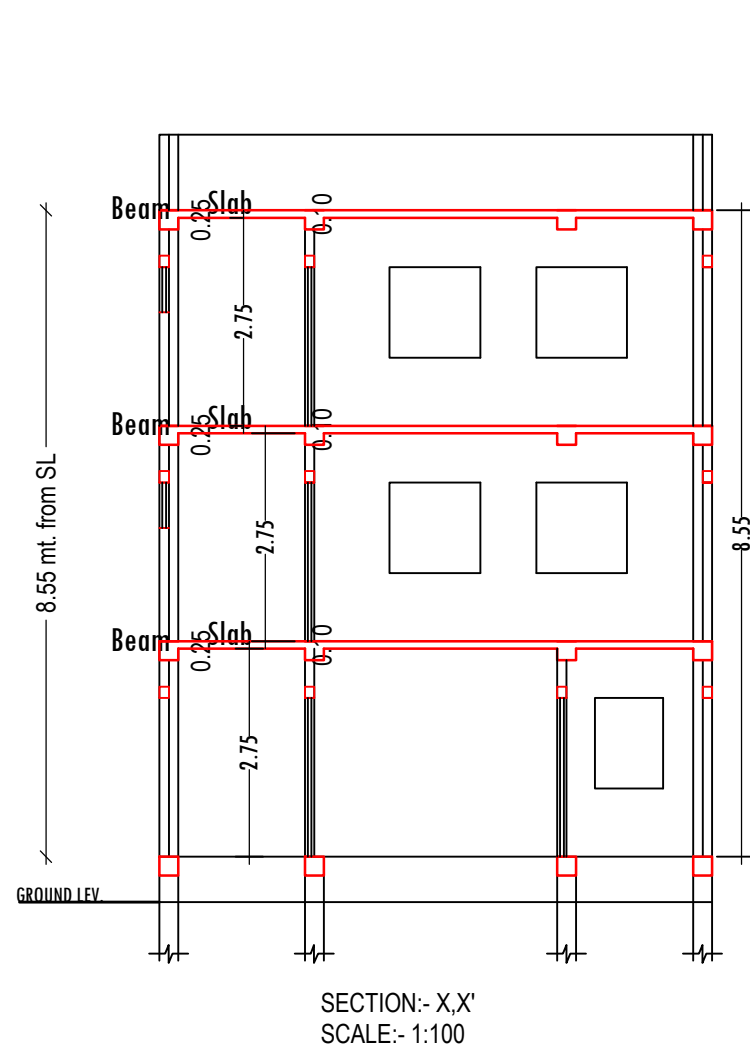

SECTION- X-X' SCALE:- 1:100

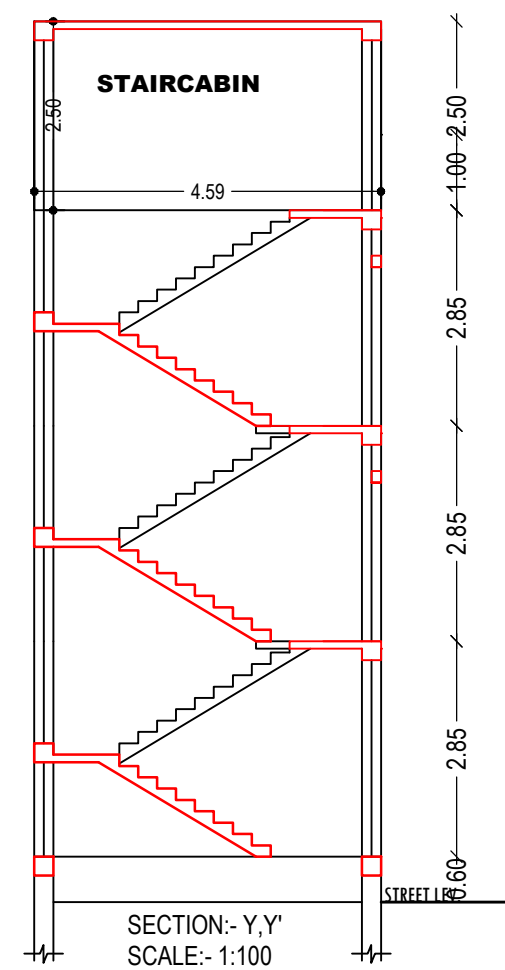

SECTION- Y-Y' SCALE:- 1:100

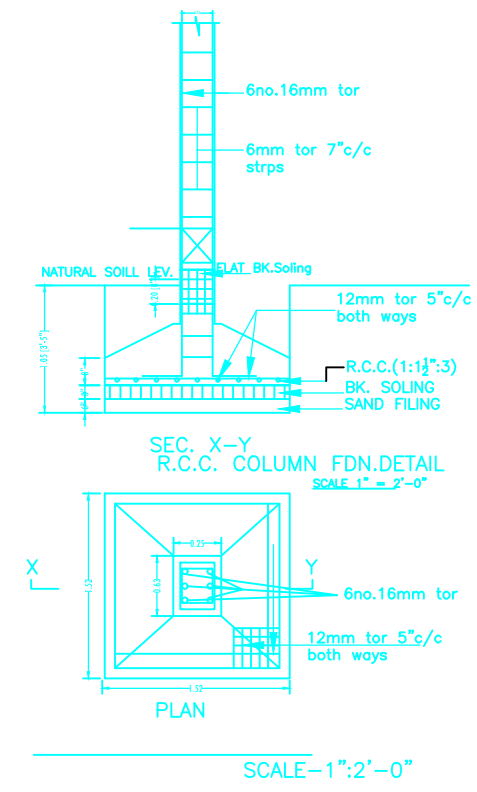

SCALE:- 1"=0'-0"

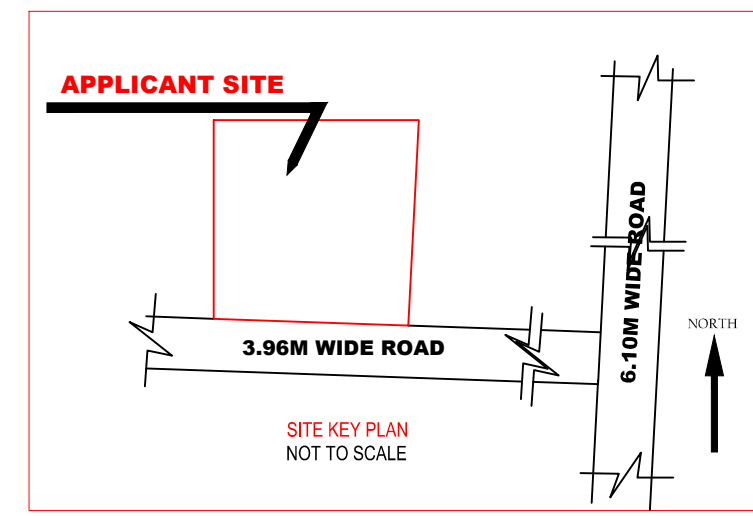
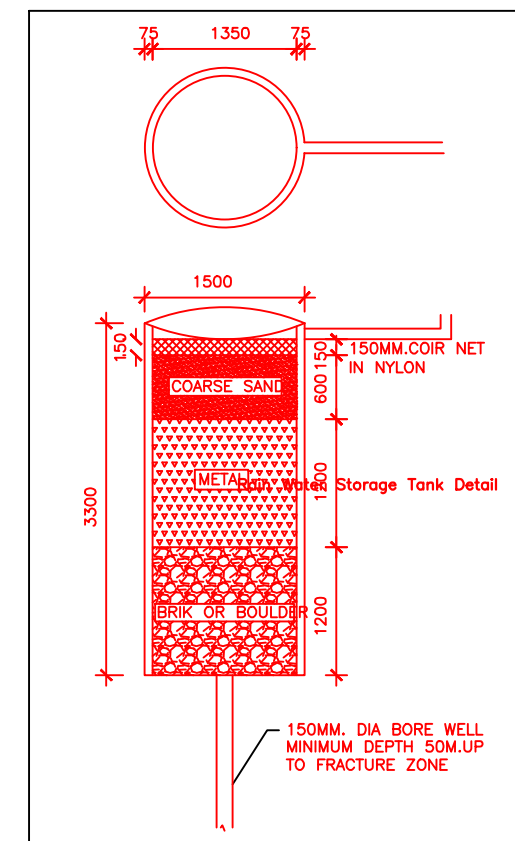

FAR & Tenement Details (Table 4c-1)

Building	No. of Same Bldg	Total Built Up Area (Sq.mt.)	Deductions (Area in Sq.mt.)	Proposed FAR Area (Sq.mt.)	Add Area in FAR (Sq.mt.)	Total FAR Area (Sq.mt.)	Total Consumed Additional FAR Area (Sq.mt.)	Tnmt (No.)
AA (SRI UPENDER RAJAK)	1	114.88	30.64	76.44	7.80	84.24	84.24	01
Grand Total :	1	114.88	30.64	76.44	7.80	84.24	84.24	01

Proposal Basic Information

Proposal File No.	JNP/IBP/0089/W10/2022
Owner Name	SRI UPENDER RAJAK
Khata No	1291
Plot No	7434
Village Name	Tilaiya
Use	Residential
SubUse	Bungalow/ Dwelling / Non Apartment

AREA STATEMENT	VERSION NO. : 1.0.64
JHUMRITILAIYA NAGAR	VERSION DATE: 16/10/2020
PARISHAD	
PROJECT DETAIL:	
Region: JHARKHAND URBAN LOCAL BODIES	Plot Use: Residential
District: KODERMA	Plot SubUse: Bungalow/ Dwelling / Non Apartment
Authority: JHUMRITILAIYA NAGAR PARISHAD	PlotNearbyReligiousStructure: NA
Inward No: JNP/IBP/0089/W10/2022	Plot/SubPlot No: 7434
Application Type: General Proposal	North: Plot No. -ARJUN RAJAK
Project Type: Building Permission	South: Road Width - 3.96M WIDE ROAD
Nature of Development: New	East: Plot No. - SURENDRA RAJAK
Location of Development Area: Old Area	West: Plot No. - KAMESHWAR SINGH
AREA DETAILS:	SQ.MT.
AREA OF PLOT (Minimum)	(A) 69.70
NET AREA OF PLOT(Gross Plot Area - Deduction from Gross Plot area)	(A-Deductions) 69.70
Deduction for Balance Plot Area(from Gross Plot Area)	
Common Plot	6.60
Total	6.60
BALANCE AREA OF PLOT(Net Plot Area - Recreational/Amenity space)	(A-Deductions) 63.10
PLOT AREA FOR COVERAGE(Net Plot Area)	(A-Deductions) 69.70
Plot Area for FAR (Net Plot Area + RoadWidening Area)	(A-Deductions) 69.70
COVERAGE CHECK	
Permissible Coverage area ( 70.00 % )	48.79
Proposed Coverage Area ( 48.09 % )	33.52
Total Prop. Coverage Area ( 48.09 % )	33.52
Balance coverage area ( 21.91 % )	15.27
FAR CHECK	
Perm. FAR Area ( 1.50 )	104.55
Incentive FAR Area ( 1.500 )	104.55
Perm. FAR Area ( 3.000 )	209.10
Total Perm. FAR area	209.10
Residential FAR	76.45
Proposed FAR Area	84.25
Total Proposed FAR Area	84.25
Consumed FAR (Factor)	1.21
Balance FAR Area	124.85
BUILT UP AREA CHECK	
Total Proposed BuiltUp Area	114.88
ARCHITECT (Regd)	MD SHOAIB ALAM
ENGINEER (Regd)	
SUPERVISOR (Regd)	
OWNER (Regd)	SRI UPENDER RAJAK
DEVELOPMENT AUTHORITY	LOCAL BODY

COLOR INDEX	
PLOT BOUNDARY	Black
ABUTTING ROAD	Green
PROPOSED CONSTRUCTION	Red
COMMON PLOT	Yellow
ROAD WIDENING AREA	Blue
EXISTING (To be retained)	Orange
EXISTING (To be demolished)	Light Blue

Floor Name	Total Built Up Area (Sq.mt.)	Deductions (Area in Sq.mt.)	Proposed FAR Area (Sq.mt.)	Add Area in FAR (Sq.mt.)	Total FAR Area (Sq.mt.)	Total Consumed Additional FAR Area (Sq.mt.)	Tnmt (No.)
Ground Floor	47.84	30.64	9.40	7.80	17.20	17.20	01
First Floor	33.52	0.00	33.52	0.00	33.52	33.52	00
Second Floor	33.52	0.00	33.52	0.00	33.52	33.52	00
Terrace Floor	0.00	0.00	0.00	0.00	0.00	0.00	00
Total :	114.88	30.64	76.44	7.80	84.24	84.24	01
Total Number of Same Buildings	1						
Total :	114.88	30.64	76.44	7.80	84.24	84.24	01

SCHEDULE OF DOOR:

BUILDING NAME	NAME	LENGTH	HEIGHT	NOS
AA (SRI UPENDER RAJAK)	D2	0.75	2.10	01
AA (SRI UPENDER RAJAK)	D1	0.90	2.10	02
AA (SRI UPENDER RAJAK)	D	1.00	2.10	04

SCHEDULE OF WINDOW/VENTILATION:

BUILDING NAME	NAME	LENGTH	HEIGHT	NOS
AA (SRI UPENDER RAJAK)	V	0.60	0.60	01
AA (SRI UPENDER RAJAK)	W2	0.90	1.20	02
AA (SRI UPENDER RAJAK)	W1	1.20	1.20	05
AA (SRI UPENDER RAJAK)	W	1.50	1.20	02

UnitBUA Table for Building :AA (SRI UPENDER RAJAK)

FLOOR	Name	UnitBUA Type	UnitBUA Area	Carpet Area	No. of Rooms	No. of Tenement
GROUND FLOOR PLAN	SPLIT FLAT A	FLAT	52.34	50.25	1	1
FIRST FLOOR PLAN	SPLIT FLAT A	FLAT	0.00	0.00	3	0
SECOND FLOOR PLAN	SPLIT FLAT A	FLAT	0.00	0.00	3	0
Total:	-	-	52.34	50.25	7	1

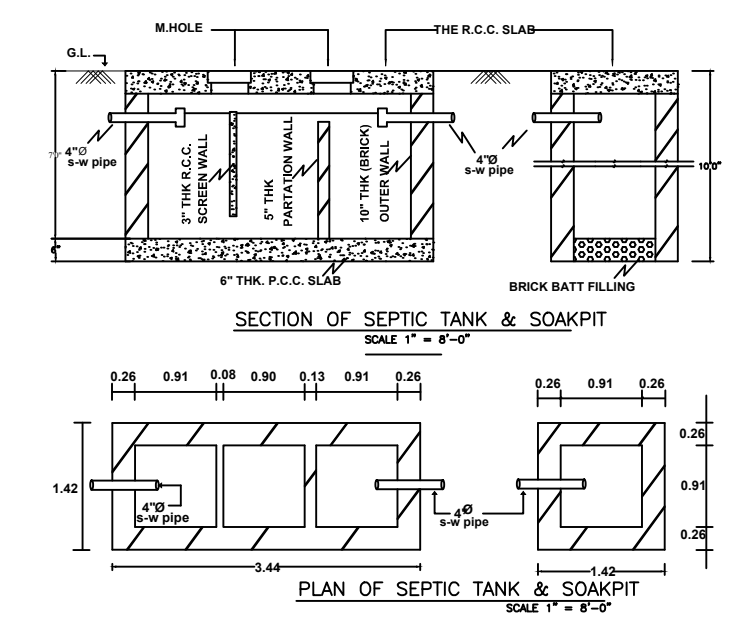

LTP NAME AND SIGNATURE	STRUCTURAL ENG'S NAME AND SIGNATURE	BUILDER NAME AND SIGNATURE	DIGITAL SIGNATURE
MD SHOAIB ALAM JNP/ENG/0001/2017			