

SITE PLAN

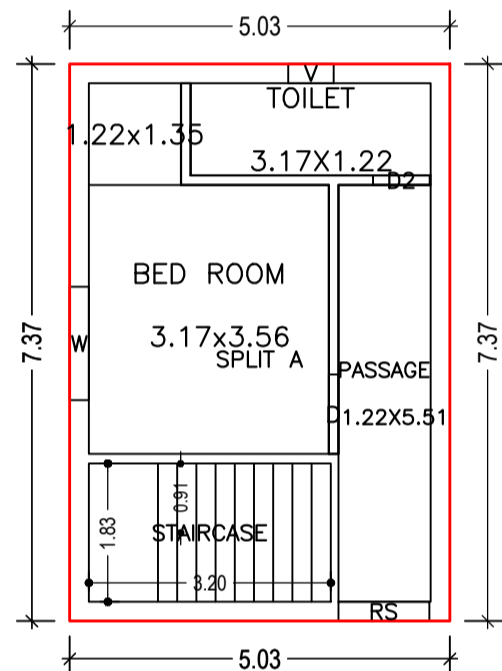

GROUND FLOOR PLAN (Proposed) (SCALE 1:100)

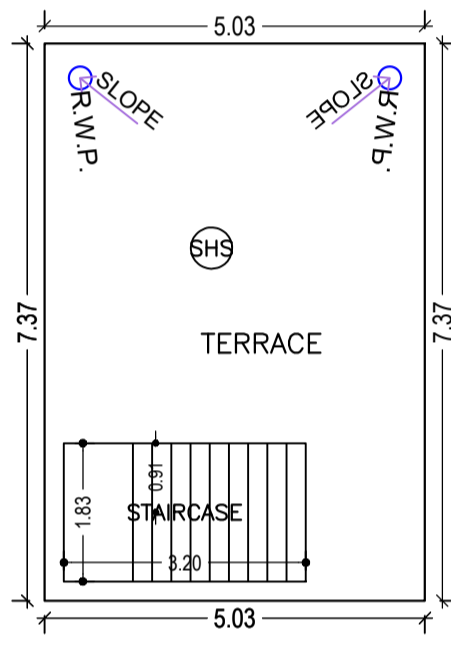

TERRACE FLOOR PLAN (SCALE 1:100)

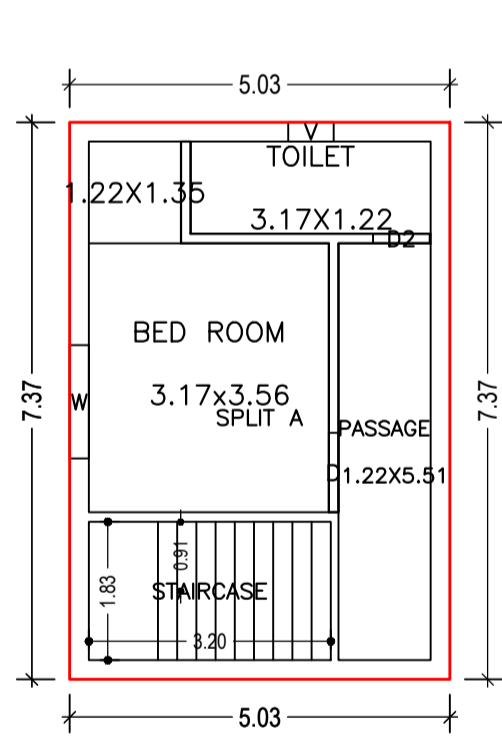

FIRST FLOOR PLAN (Proposed) (SCALE 1:100)

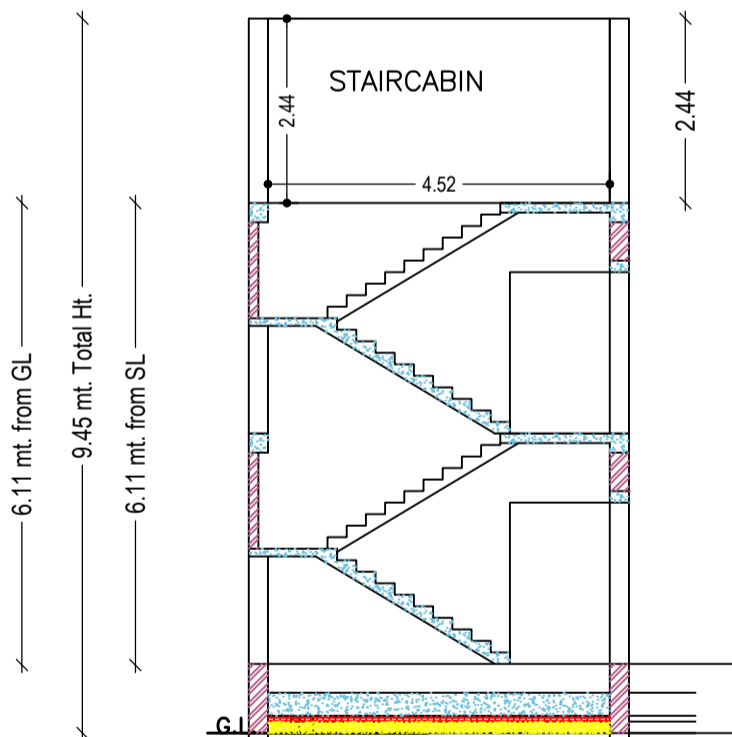

CROSS SECTION (A)

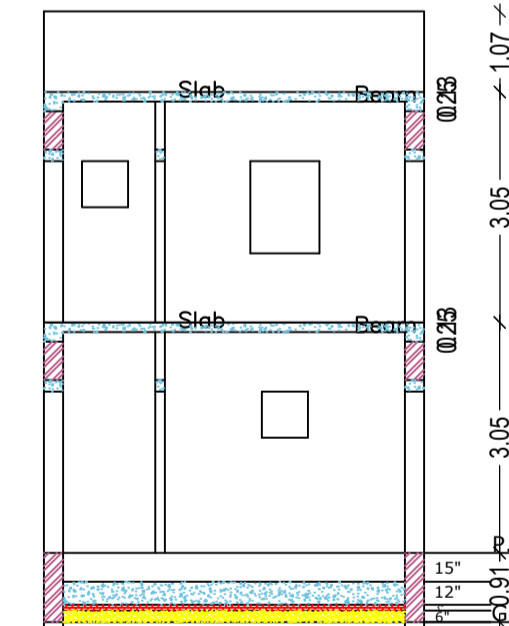

CROSS SECTION (B)

Floor Name	Total Built Up Area (Sq.mt.)	Proposed FAR Area (Sq.mt.) Resi.	Total FAR Area (Sq.mt.)	Total Consumed Additional FAR Area (Sq.mt.)	Tnmt (No.)
Ground Floor	37.06	37.06	37.06	37.06	01
First Floor	37.06	37.06	37.06	37.06	00
Terrace Floor	0.00	0.00	0.00	0.00	00
Total :	74.12	74.12	74.12	74.12	01
Total Number of Same Buildings	1				
Total :	74.12	74.12	74.12	74.12	01

SCHEDULE OF DOOR:

BUILDING NAME	NAME	LENGTH	HEIGHT	NOS
A (RESIDENTIAL)	D2	0.75	2.10	02
A (RESIDENTIAL)	D	1.05	2.10	02
A (RESIDENTIAL)	RS	1.20	2.10	01

SCHEDULE OF WINDOW/VENTILATION:

BUILDING NAME	NAME	LENGTH	HEIGHT	NOS
A (RESIDENTIAL)	V	0.60	0.90	02
A (RESIDENTIAL)	W	1.50	1.20	02

UnitBUA Table for Building :A (RESIDENTIAL)

FLOOR	Name	UnitBUA Type	UnitBUA Area	Carpet Area	No. of Rooms	No. of Tenement
GROUND FLOOR PLAN	SPLIT A	FLAT	49.74	47.69	3	1
FIRST FLOOR PLAN	SPLIT A	FLAT	0.00	0.00	3	0
Total:	-	-	49.74	47.69	6	1

FAR & Tenement Details (Table 4c-1)

Building	No. of Same Bldg	Total Built Up Area (Sq.mt.)	Proposed FAR Area (Sq.mt.) Resi.	Total FAR Area (Sq.mt.)	Total Consumed Additional FAR Area (Sq.mt.)	Tnmt (No.)
A (RESIDENTIAL)	1	74.12	74.12	74.12	74.12	01
Grand Total :	1	74.12	74.12	74.12	74.12	01

Proposal Basic Information

Proposal File No.	JNP/IBP/0085/W07/2022
Owner Name	SMT ANAMIKA KUMARI
Khata No	05
Plot No	29
Village Name	Jhalpo
Use	Residential
SubUse	Bungalow/ Dwelling / Non Apartment

AREA STATEMENT		VERSION NO. : 1.0.64
JHUMRITILAIYA NAGAR PARISHAD		VERSION DATE: 16/10/2020
PROJECT DETAIL:		
Region: JHARKHAND URBAN LOCAL BODIES	Plot Use: Residential	
District: KODERMA	Plot SubUse: Bungalow/ Dwelling / Non Apartment	
Authority: JHUMRITILAIYA NAGAR PARISHAD	PlotNearbyReligiousStructure: NA	
Inward No: JNP/IBP/0085/W07/2022	PlotSubPlot No: 29	
Application Type: General Proposal	North: Plot No. - URMILA DEVI	
Project Type: Building Permission	South: Plot No. - 30	
Nature of Development: New	East: Plot No. - 34	
Location of Development Area: Old Area	West: Road Width - 6.10	
AREA DETAILS:		
AREA OF PLOT (Minimum)	(A)	SQ.MT. 60.70
NET AREA OF PLOT(Gross Plot Area - Deduction from Gross Plot area)	(A-Deductions)	60.70
Deduction for Balance Plot Area(from Gross Plot Area)		
Common Plot		6.50
Total		6.50
BALANCE AREA OF PLOT(Net Plot Area - Recreational/Amenity space)	(A-Deductions)	54.19
PLOT AREA FOR COVERAGE(Net Plot Area)	(A-Deductions)	60.70
Plot Area for FAR (Net Plot Area + RoadWidening Area)	(A-Deductions)	60.70
COVERAGE CHECK		
Permissible Coverage area (70.00 %)		42.49
Proposed Coverage Area (61.06 %)		37.06
Total Prop. Coverage Area (61.06 %)		37.06
Balance coverage area (8.95 %)		5.43
FAR CHECK		
Perm. FAR Area (2.00)		121.40
Incentive FAR Area (2.000)		121.40
Perm. FAR Area (4.000)		242.80
Total Perm. FAR area		242.80
Residential FAR		74.12
Proposed FAR Area		74.12
Total Proposed FAR Area		74.12
Consumed FAR (Factor)		1.22
Balance FAR Area		168.68
BUILT UP AREA CHECK		
Total Proposed BuiltUp Area		74.12
ARCHITECT (Regd)	KIRAN KUMARI	
ENGINEER (Regd)		
SUPERVISOR (Regd)		
OWNER (Regd)	SMT ANAMIKA KUMARI	
DEVELOPMENT AUTHORITY		LOCAL BODY

COLOR INDEX	
PLOT BOUNDARY	Black
ABUTTING ROAD	Red
PROPOSED CONSTRUCTION	Green
COMMON PLOT	Yellow
ROAD WIDENING AREA	Blue
EXISTING (To be retained)	Orange
EXISTING (To be demolished)	Light Blue

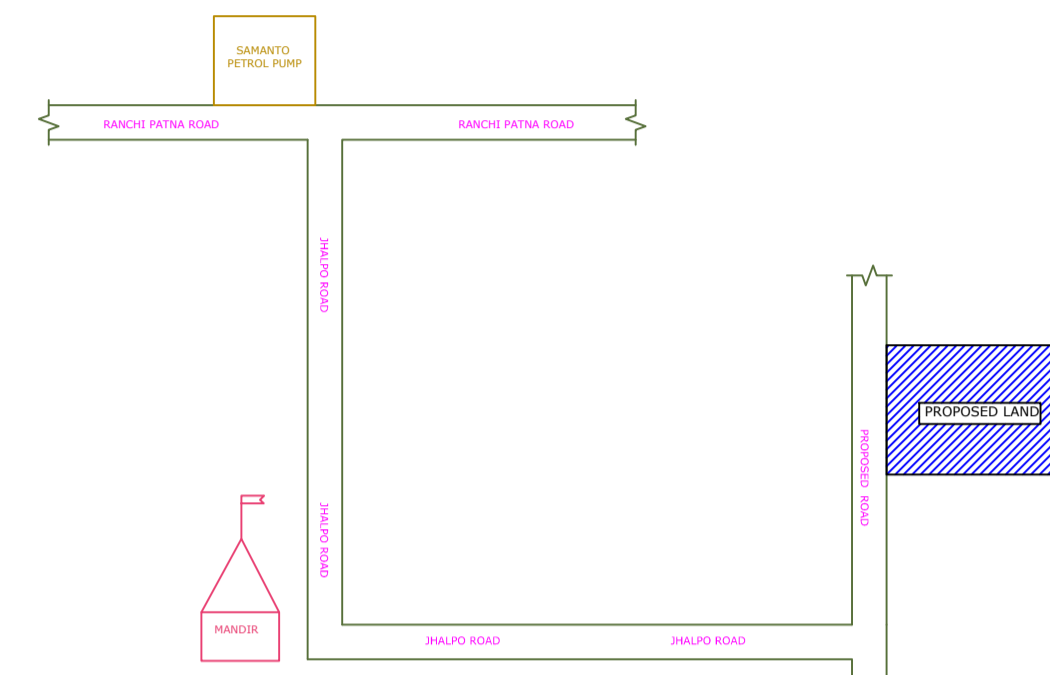

LOCATION PLAN (SCALE -1''16')

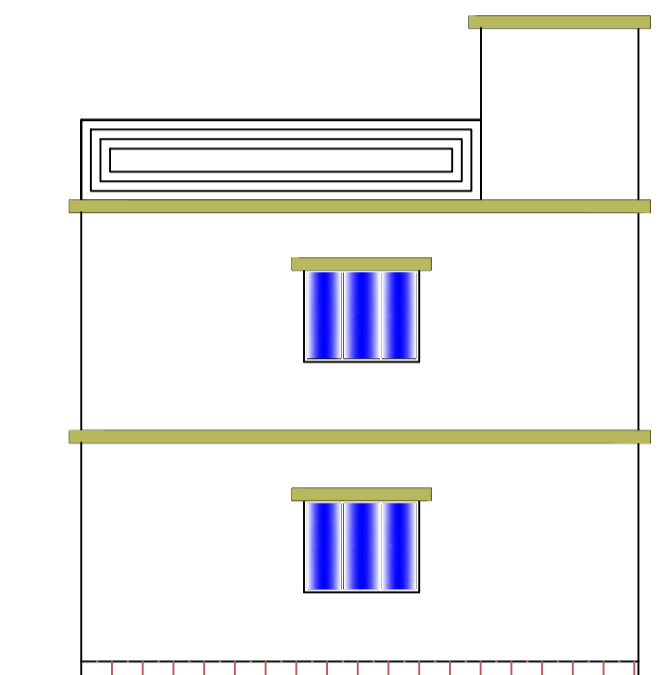

CROSS ELEVATION

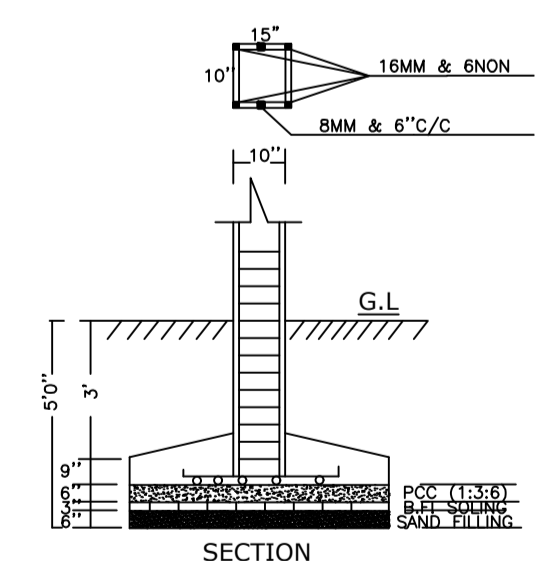

SECTION

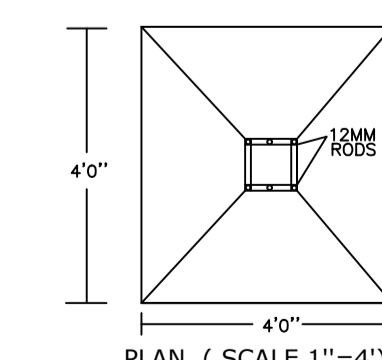

PLAN (SCALE 1''=4')

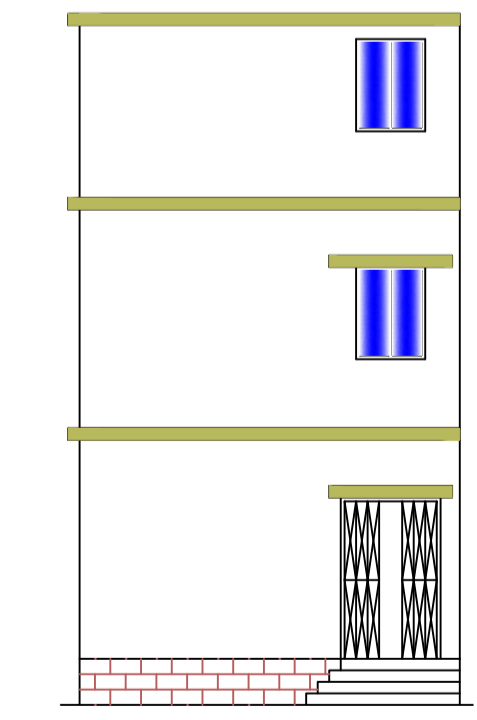

FRONT ELEVATION

Buildingwise Floor FAR Details

Floor Name	Building Name A (RESIDENTIAL)		Total	
	Proposed Built Up Area (Sq.mt.)	Proposed FAR Area (Sq.mt.)	Total Proposed Built Up Area (Sq.mt.)	Total FAR Area (Sq.mt.)
Ground Floor	37.06	37.06	37.06	37.06
First Floor	37.06	37.06	37.06	37.06
Terrace Floor	0.00	0.00	0.00	0.00
Total :	74.12	74.12	74.12	74.12

Building USE/SUBUSE Details

Building Name	Building Use	Building SubUse	Building Structure
A (RESIDENTIAL)	Residential	Bungalow/ Dwelling / Non Apartment	Non-Highrise

LTP NAME AND SIGNATURE	STRUCTURAL ENG'S NAME AND SIGNATURE	BUILDER NAME AND SIGNATURE	DIGITAL SIGNATURE
KIRAN KUMARI JNP/ENG/001/2019			