

SITE PLAN  
SCALE: 1:100

FAR & Tenement Details (Table 4c-1)

Building	No. of Same Bldg	Total Built Up Area (Sq.mt.)	Proposed FAR Area (Sq.mt.) Resi.	Total FAR Area (Sq.mt.)	Total Consumed Additional FAR Area (Sq.mt.)	Trmt (No.)
AA (SMT DEVANTI DEVI)	1	47.95	47.95	47.95	47.95	01
<b>Grand Total :</b>	<b>1</b>	<b>47.95</b>	<b>47.95</b>	<b>47.95</b>	<b>47.95</b>	<b>01</b>

Proposal Basic Information

Proposal File No.	JNP/IBP/0053/W05/2023
Owner Name	SMT DEVANTI DEVI
Khata No	77
Plot No	495
Village Name	Asana
Use	Residential
SubUse	Bungalow/ Dwelling / Non Apartment

AREA STATEMENT	VERSION NO. : 1.0.66
JHUMRITILAIYA NAGAR PARISHAD	VERSION DATE: 16/10/2020
PROJECT DETAIL:	
Region: JHARKHAND URBAN LOCAL BODIES	Plot Use: Residential
District: KODERMA	Plot SubUse: Bungalow/ Dwelling / Non Apartment
Authority: JHUMRITILAIYA NAGAR PARISHAD	PlotNearbyReligiousStructure: NA
Inward No: JNP/IBP/0053/W05/2023	PlotSubPlot No: 495
Application Type: General Proposal	North: Plot No. - PACHO MAHTO
Project Type: Building Permission	South: Road Width - 3.66M WIDE KATCHA ROAD
Nature of Development: New	East: Plot No. - KHEMAN YADAV
Location of Development Area: Old Area	West: Plot No. - KARTIK YADAV
AREA DETAILS:	
AREA OF PLOT (Minimum)	(A) 104.20
NET AREA OF PLOT(Gross Plot Area - Deduction from Gross Plot area)	(A-Deductions) 104.20
Deduction for Balance Plot Area(from Gross Plot Area)	
Common Plot	10.28
Total	10.28
BALANCE AREA OF PLOT(Net Plot Area - Recreational/Amenity space)	(A-Deductions) 93.92
PLOT AREA FOR COVERAGE(Net Plot Area)	(A-Deductions) 104.20
Plot Area for FAR (Net Plot Area + RoadWidening Area)	(A-Deductions) 104.20
COVERAGE CHECK	
Permissible Coverage area ( 70.00 % )	72.94
Proposed Coverage Area ( 46.02 % )	47.95
Total Prop. Coverage Area ( 46.02 % )	47.95
Balance coverage area ( 23.98 % )	24.99
FAR CHECK	
Perm. FAR Area ( 1.500 )	156.30
Total Perm. FAR area	156.30
Residential FAR	47.95
Proposed FAR Area	47.95
Total Proposed FAR Area	47.95
Consumed FAR (Factor)	0.46
Balance FAR Area	108.35
BUILT UP AREA CHECK	
Total Proposed BuiltUp Area	47.95
ARCHITECT (Regd)	MD SHOAB ALAM
ENGINEER (Regd)	
SUPERVISOR (Regd)	
OWNER (Regd)	SMT DEVANTI DEVI
DEVELOPMENT AUTHORITY	
	LOCAL BODY

COLOR INDEX	
PLOT BOUNDARY	
ABUTTING ROAD	
PROPOSED CONSTRUCTION	
COMMON PLOT	
ROAD WIDENING AREA	
EXISTING (To be retained)	
EXISTING (To be demolished)	

Buildingwise Floor FAR Details

Floor Name	Building Name AA (SMT DEVANTI DEVI)		Total	
	Proposed Built Up Area (Sq.mt.)	Proposed FAR Area (Sq.mt.)	Total Proposed Built Up Area (Sq.mt.)	Total FAR Area (Sq.mt.)
Ground Floor	47.95	47.95	47.95	47.95
Terrace Floor	0.00	0.00	0.00	0.00
<b>Total :</b>	<b>47.95</b>	<b>47.95</b>	<b>47.95</b>	<b>47.95</b>

Building USE/SUBUSE Details

Building Name	Building Use	Building SubUse	Building Structure
AA (SMT DEVANTI DEVI)	Residential	Bungalow/ Dwelling / Non Apartment	Non-Highrise

LTP NAME AND SIGNATURE	STRUCTURAL ENG'S NAME AND SIGNATURE	BUILDER NAME AND SIGNATURE	DIGITAL SIGNATURE
MD SHOAB ALAM JNP/ENG/0001/2017			

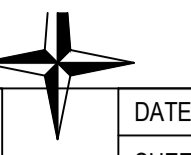

Proposal Basic Information	
Proposal File No.	JNP/IBP/0053/W05/2023
Owner Name	SMT DEVANTI DEVI
Khata No	77
Plot No	495
Village Name	Asana
Use	Residential
SubUse	Bungalow/ Dwelling / Non Apartment

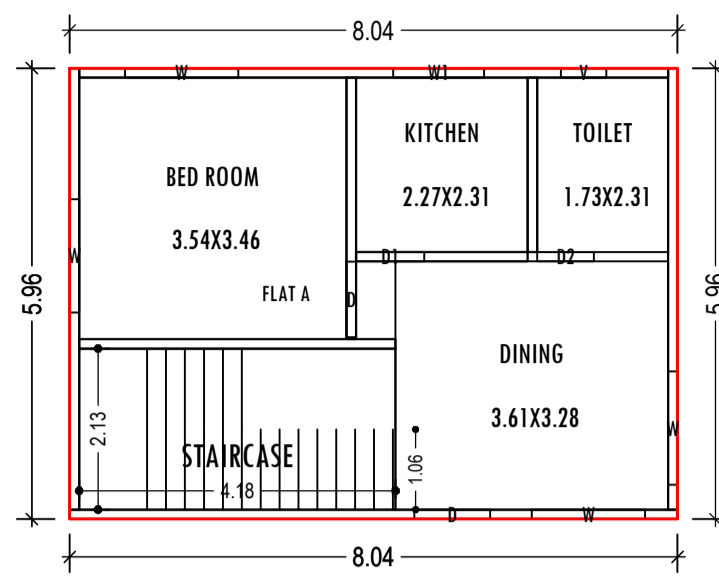

GROUND FLOOR PLAN (Proposed) (SCALE 1:100)

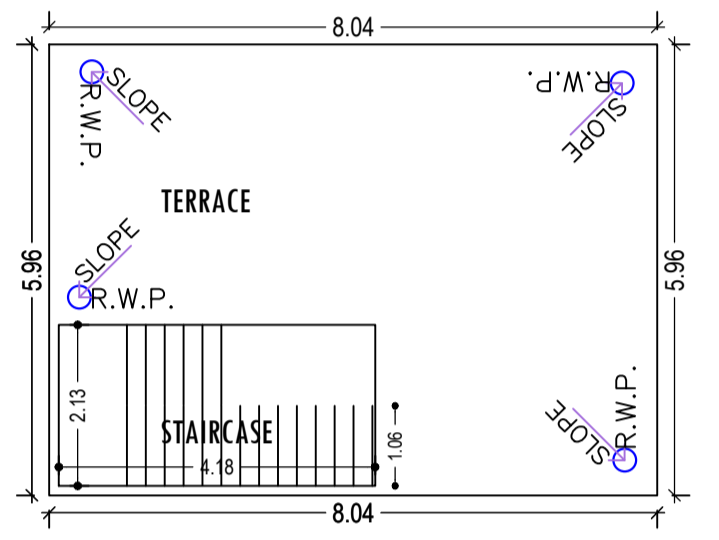

TERRACE FLOOR PLAN (SCALE 1:100)

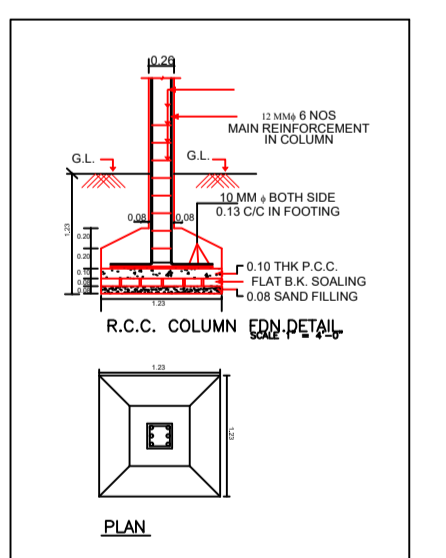
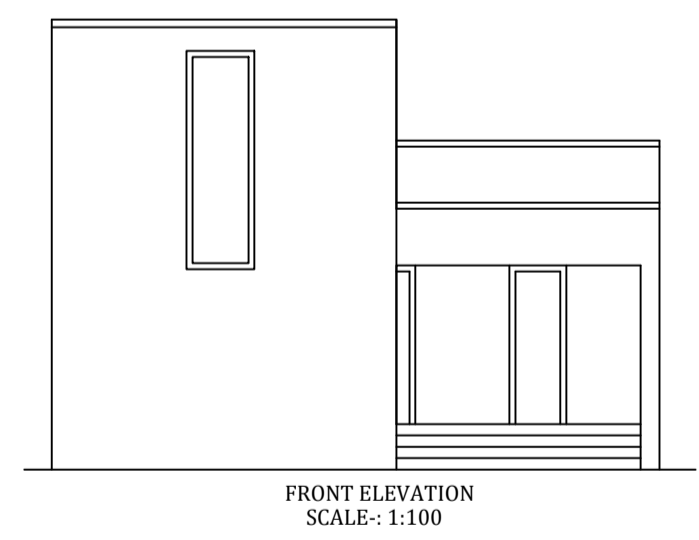
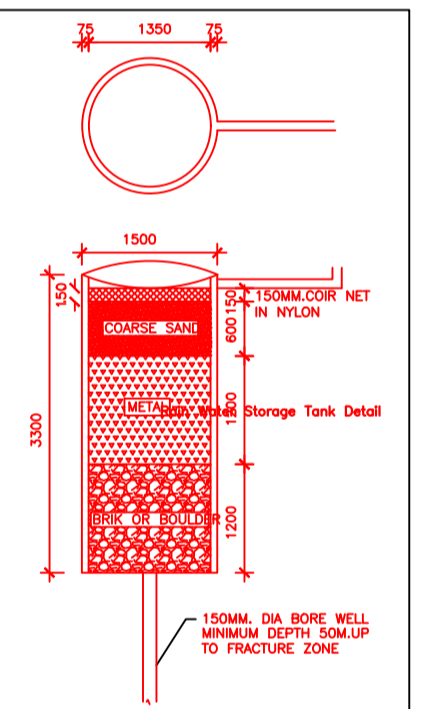
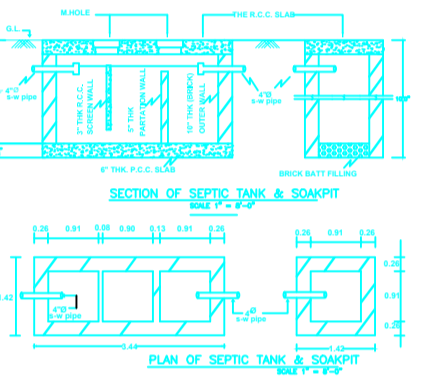
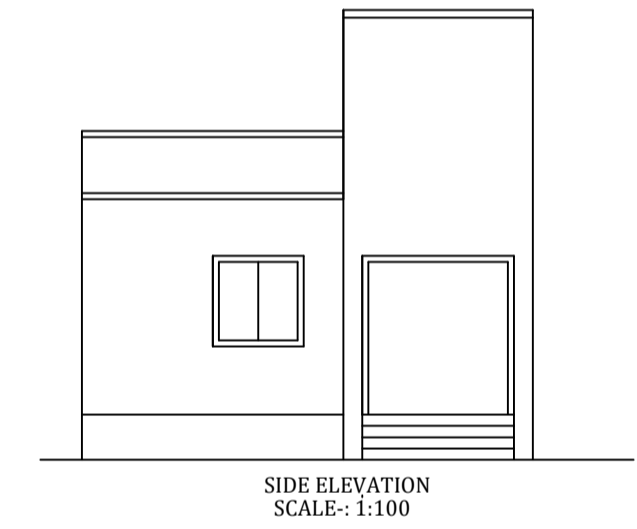
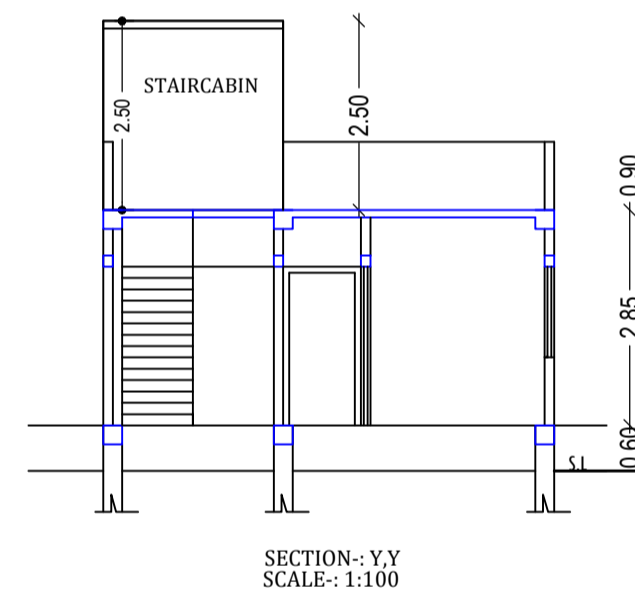
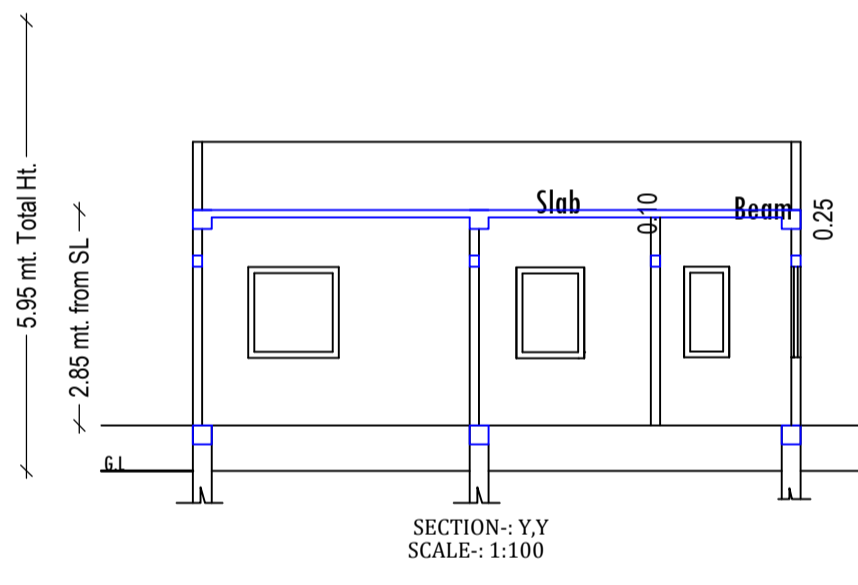
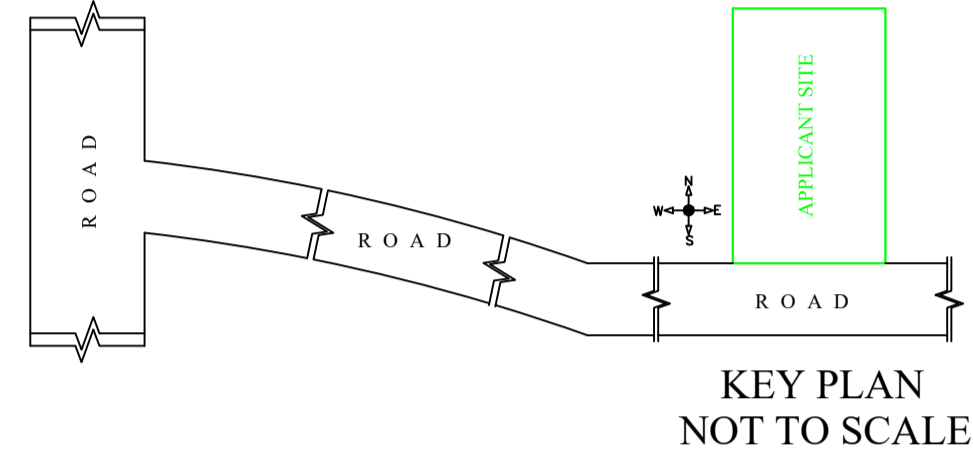

Building :-AA (SMT DEVANTI DEVI)

Floor Name	Total Built Up Area (Sq.mt.)	Proposed FAR Area (Sq.mt.)	Total FAR Area (Sq.mt.)	Total Consumed Additional FAR Area (Sq.mt.)	Tnmt (No.)
Ground Floor	47.95	47.95	47.95	47.95	01
Terrace Floor	0.00	0.00	0.00	0.00	00
Total :	47.95	47.95	47.95	47.95	01
Total Number of Same Buildings	1				
Total :	47.95	47.95	47.95	47.95	01

SCHEDULE OF DOOR:

BUILDING NAME	NAME	LENGTH	HEIGHT	NOS
AA (SMT DEVANTI DEVI)	D2	0.75	2.10	01
AA (SMT DEVANTI DEVI)	D1	0.90	2.10	01
AA (SMT DEVANTI DEVI)	D	1.00	2.10	02

SCHEDULE OF WINDOW/VENTILATION:

BUILDING NAME	NAME	LENGTH	HEIGHT	NOS
AA (SMT DEVANTI DEVI)	V	0.60	0.60	01
AA (SMT DEVANTI DEVI)	W1	1.20	1.20	01
AA (SMT DEVANTI DEVI)	W	1.50	1.20	04

UnitBUA Table for Building :-AA (SMT DEVANTI DEVI)

FLOOR	Name	UnitBUA Type	UnitBUA Area	Carpet Area	No. of Rooms	No. of Tenement
GROUND FLOOR PLAN	FLAT A	FLAT	35.07	34.07	4	1
Total:	-	-	35.07	34.07	4	1

LTP NAME AND SIGNATURE	STRUCTURAL ENG'S NAME AND SIGNATURE	BUILDER NAME AND SIGNATURE	DIGITAL SIGNATURE
MD SHOAIB ALAM JNP/ENG/0001/2017			