

SITE PLAN
SCALE : 1=100

SITE PLAN

FAR & Tenement Details (Table 4c-1)

Building	No. of Same Bldg	Total Built Up Area (Sq.mt.)	Proposed FAR Area (Sq.mt.)		Total FAR Area (Sq.mt.)	Total Consumed Additional FAR Area (Sq.mt.)	Tnmt (No.)
			Resi.	Commercial			
AA (SHAHJADI KHATUN)	1	212.28	141.52	70.76	212.28	212.28	02
Grand Total :	1	212.28	141.52	70.76	212.28	212.28	02

Proposal Basic Information

Proposal File No.	JNP/IBP/0025/W06/2023
Owner Name	SHAHJADI KHATUN
Khata No	12,21/124
Plot No	1304,1301
Village Name	Asana
Use	Mixed
SubUse	Resi+Comm

Required Parking (Table 7a)

Building Name	Type	SubUse	Area (Sq.mt.)	Units		Car		Visitors Car		TwoWheeler	
				Reqd.	Prop.	Reqd./Unit	Prop.	Reqd./Unit	Prop.	Reqd./Unit	Prop.
AA (SHAHJADI KHATUN)	Commercial	ResiComm Bldg	> 0	200	60.81	1	1	-	-	-	-
		Mixed	> 0	1	1.00	1	1	-	-	-	-
	Total :		-	-	-	-	2	2	-	1	1

Parking Check (Table 7b)

Vehicle Type	Reqd.		Prop.	
	No.	Area	No.	Area
Car	-	-	2	25.00
Total Car	2	25.00	2	25.00
Visitor's Car Parking	-	-	1	12.50
Total Visitor Parking	1	12.50	1	12.50
TwoWheeler	-	-	1	2.00
Total TwoWheeler	1	2.00	1	2.00
Other Parking	-	-	-	8.37
Total		39.50		49.87

AREA STATEMENT JHUMRITLAIYA NAGAR PARISHAD	VERSION NO. : 1.0.66 VERSION DATE: 16/10/2020
PROJECT DETAIL:	
Region: JHARKHAND URBAN LOCAL BODIES	Plot Use: Mixed
District: KODERMA	Plot SubUse: Resi+Comm
Authority: JHUMRITLAIYA NAGAR PARISHAD	Plot/Nearby/Religious/Structure: NA
Inward No: JNP/IBP/0025/W06/2023	Plot/SubPlot No: 1304,1301
Application Type: General Proposal	North: Plot No. - JULEKHA KHATUN
Project Type: Building Permission	South: Plot No. - SABBIR AHMED
Nature of Development: New	East: Road Width - 45M WIDE N.H.31
Location of Development Area: Old Area	West: Plot No. - MD KARIM
AREA DETAILS:	SQ.MT.
AREA OF PLOT (Minimum)	(A) 169.67
Deduction for NetPlot Area	
Road Widening Area	3.57
Total	3.57
NET AREA OF PLOT(Gross Plot Area - Deduction from Gross Plot area)	(A-Deductions) 166.10
Deduction for Balance Plot Area(from Gross Plot Area)	
Road Widening Area	3.57
Common Plot	17.11
Total	20.68
BALANCE AREA OF PLOT(Net Plot Area - Recreational/Amenity space)	(A-Deductions) 148.99
PLOT AREA FOR COVERAGE(Net Plot Area)	(A-Deductions) 166.10
Plot Area for FAR (Net Plot Area + RoadWidening Area)	(A-Deductions) 166.10
COVERAGE CHECK	
Permissible Coverage area (70.00 %)	116.27
Proposed Coverage Area (42.60 %)	70.76
Total Prop. Coverage Area (42.6 %)	70.76
Balance coverage area (27.40 %)	45.51
FAR CHECK	
Perm. FAR Area (2.000)	332.20
Total Perm. FAR area	332.20
Residential FAR	141.52
Commercial FAR	70.76
Proposed FAR Area	212.28
Total Proposed FAR Area	212.28
Consumed FAR (Factor)	1.28
Balance FAR Area	119.92
BUILT UP AREA CHECK	
Total Proposed BuiltUp Area	212.28
ARCHITECT (Regd)	MD SHOAB ALAM
ENGINEER (Regd)	
SUPERVISOR (Regd)	
OWNER (Regd)	SHAHJADI KHATUN
DEVELOPMENT AUTHORITY	LOCAL BODY

COLOR INDEX	
PLOT BOUNDARY	Black
ABUTTING ROAD	Green
PROPOSED CONSTRUCTION	Red
COMMON PLOT	Yellow
ROAD WIDENING AREA	Blue
EXISTING (To be retained)	Light Blue
EXISTING (To be demolished)	Light Yellow

Buildingwise Floor FAR Details

Floor Name	Building Name AA (SHAHJADI KHATUN)		Total	
	Proposed Built Up Area (Sq.mt.)	Proposed FAR Area (Sq.mt.)	Total Proposed Built Up Area (Sq.mt.)	Total FAR Area (Sq.mt.)
Ground Floor	70.76	70.76	70.76	70.76
First Floor	70.76	70.76	70.76	70.76
Second Floor	70.76	70.76	70.76	70.76
Terrace Floor	0.00	0.00	0.00	0.00
Total :	212.28	212.28	212.28	212.28

Building USE/SUBUSE Details

Building Name	Building Use	Building SubUse	Building Structure
AA (SHAHJADI KHATUN)	Commercial	ResiComm Bldg	Non-Highrise

LTP NAME AND SIGNATURE	STRUCTURAL ENG'S NAME AND SIGNATURE	BUILDER NAME AND SIGNATURE	DIGITAL SIGNATURE
MD SHOAB ALAM JNP/ENG/001/2017			

Proposal Basic Information

Proposal File No.	JNP/IBP/0025/W06/2023
Owner Name	SHAHJADI KHATUN
Khata No	12,21/124
Plot No	1304,1301
Village Name	Asana
Use	Mixed
SubUse	Resi+Comm

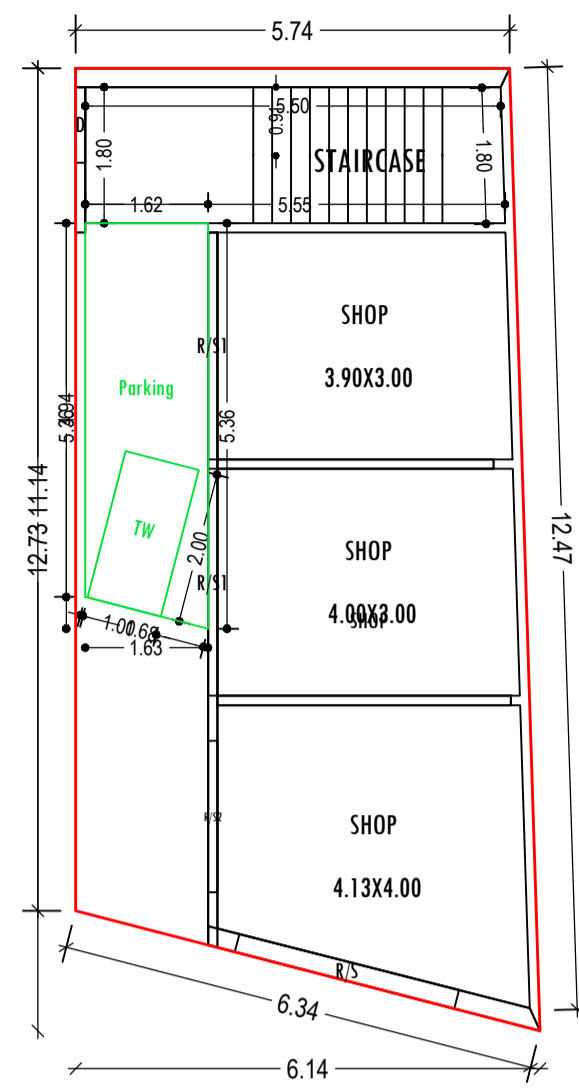

GROUND FLOOR PLAN (Proposed) (SCALE 1:100)

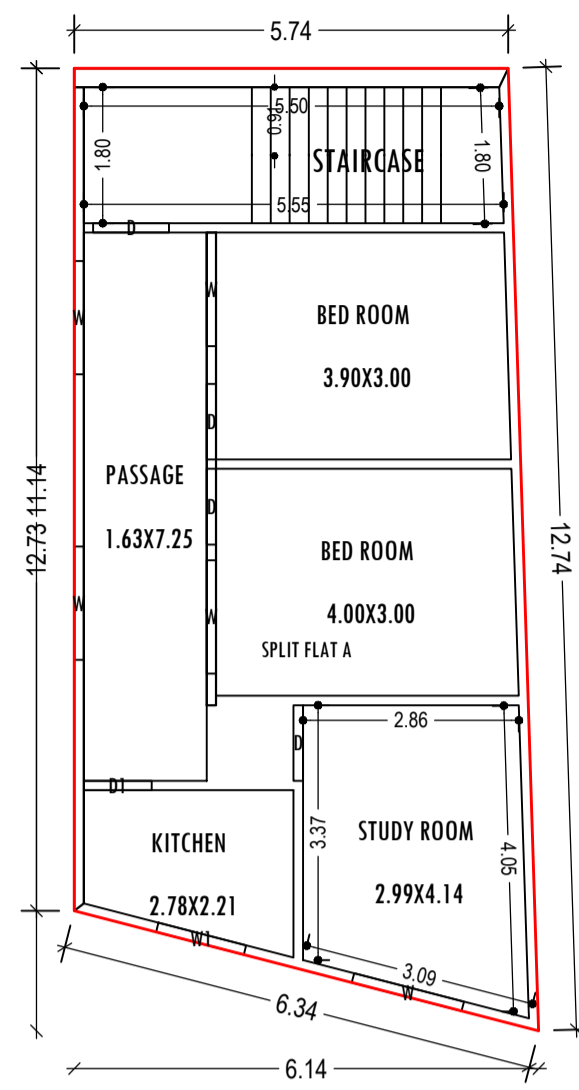

SECOND FLOOR PLAN (Proposed) (SCALE 1:100)

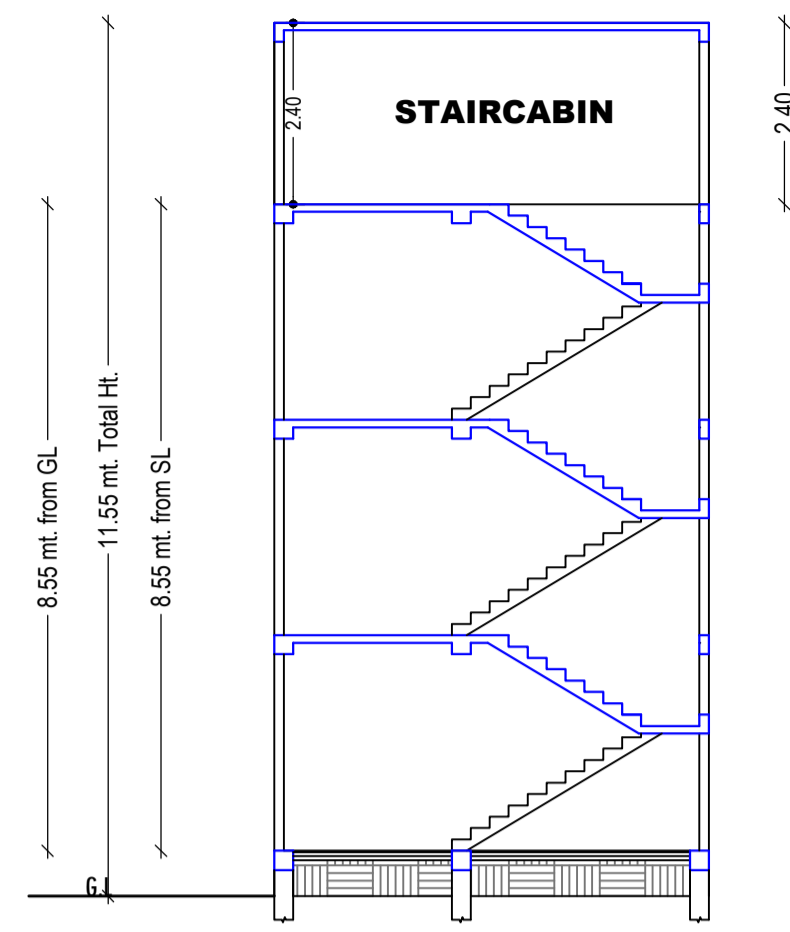

SECTION- A.A' SCALE - 1=100

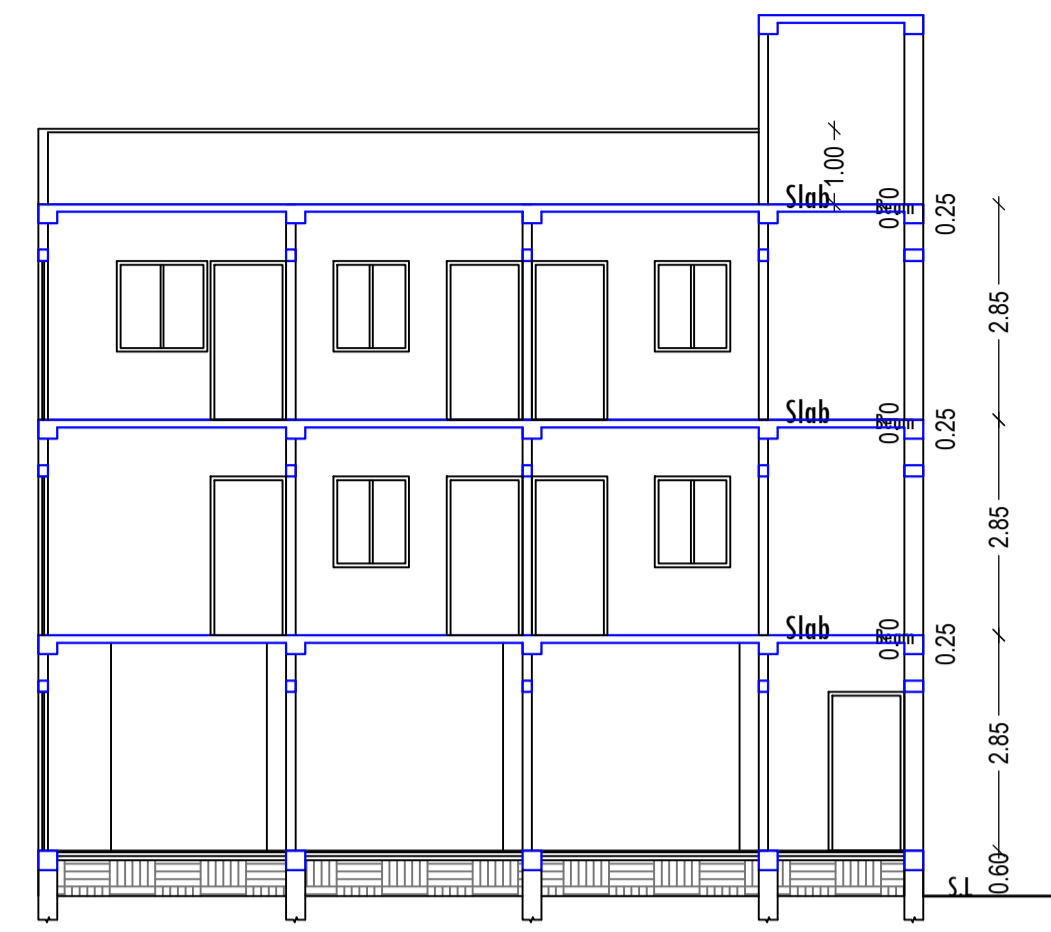

SECTION- B.B' SCALE - 1=100

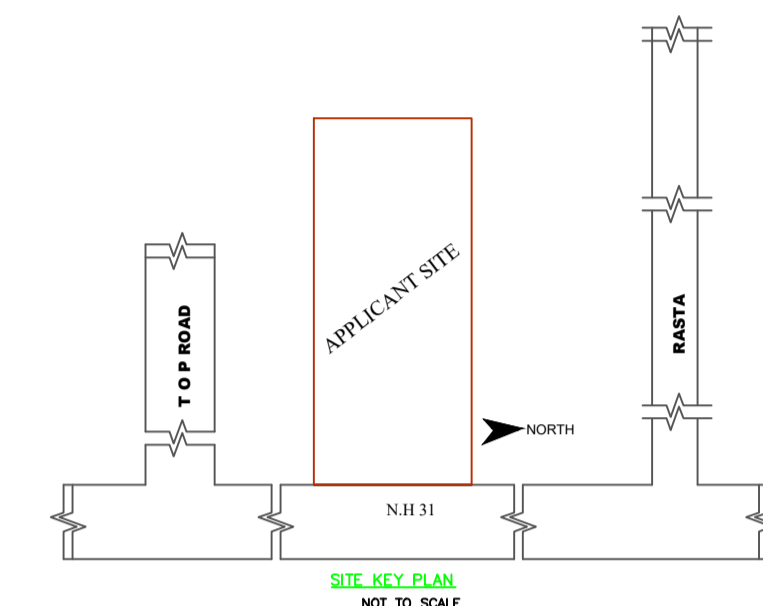

SITE KEY PLAN NOT TO SCALE

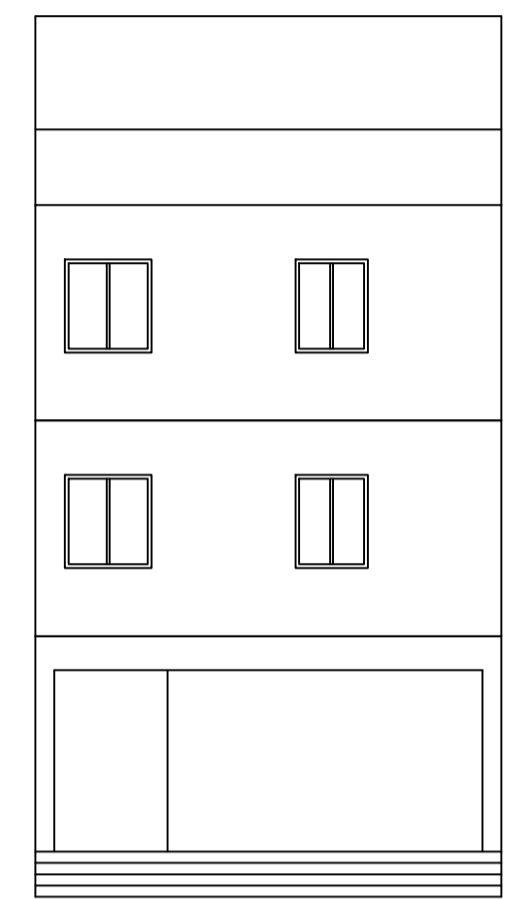

FRONT ELEVATION SCALE :: 1=100

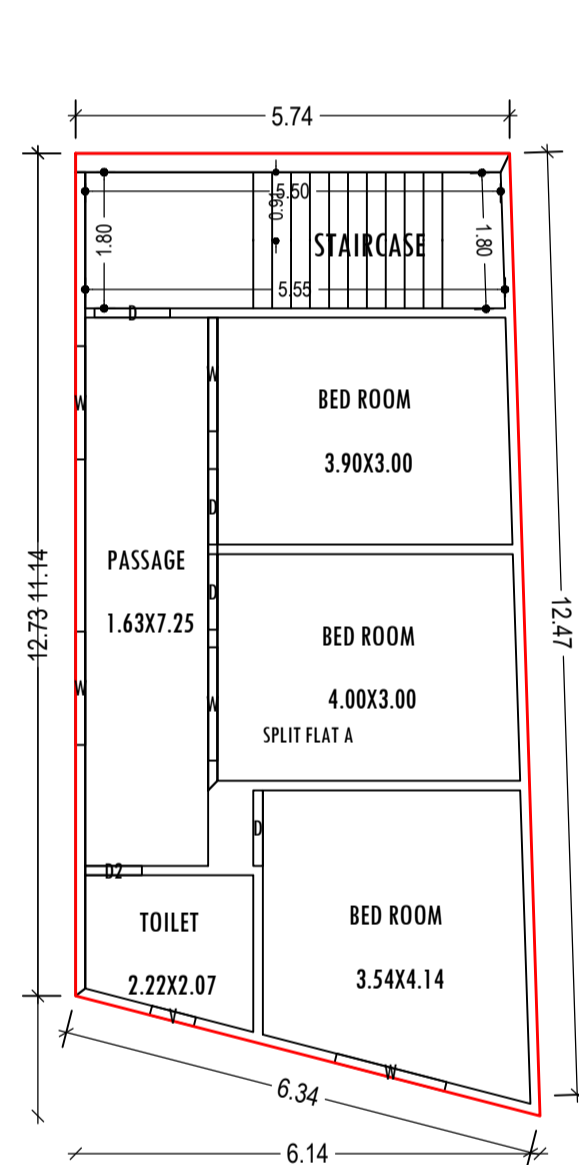

FIRST FLOOR PLAN (Proposed) (SCALE 1:100)

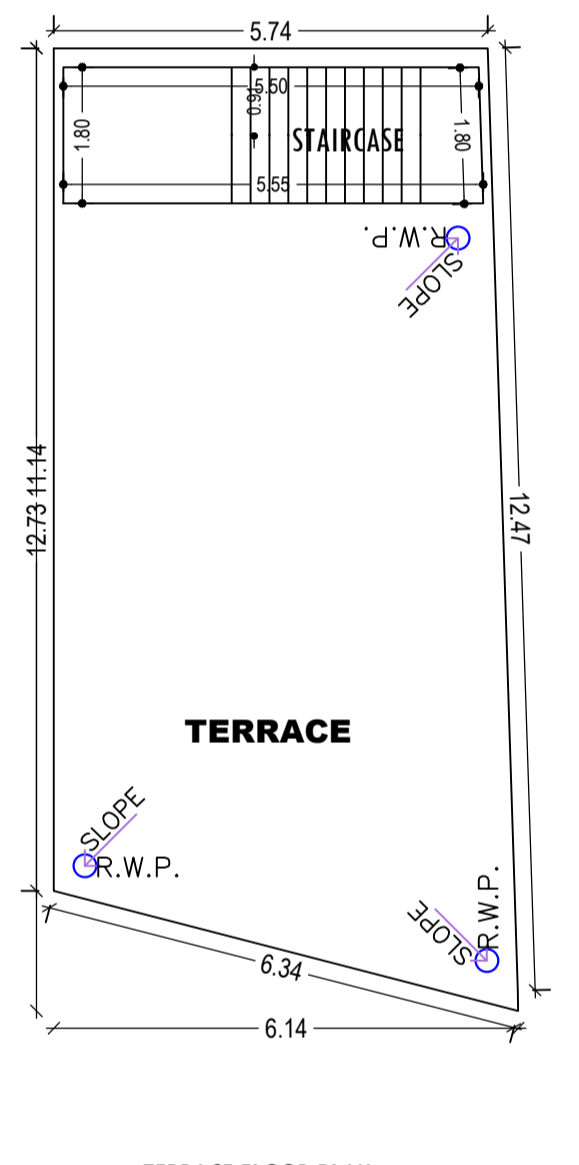

TERRACE FLOOR PLAN (SCALE 1:100)

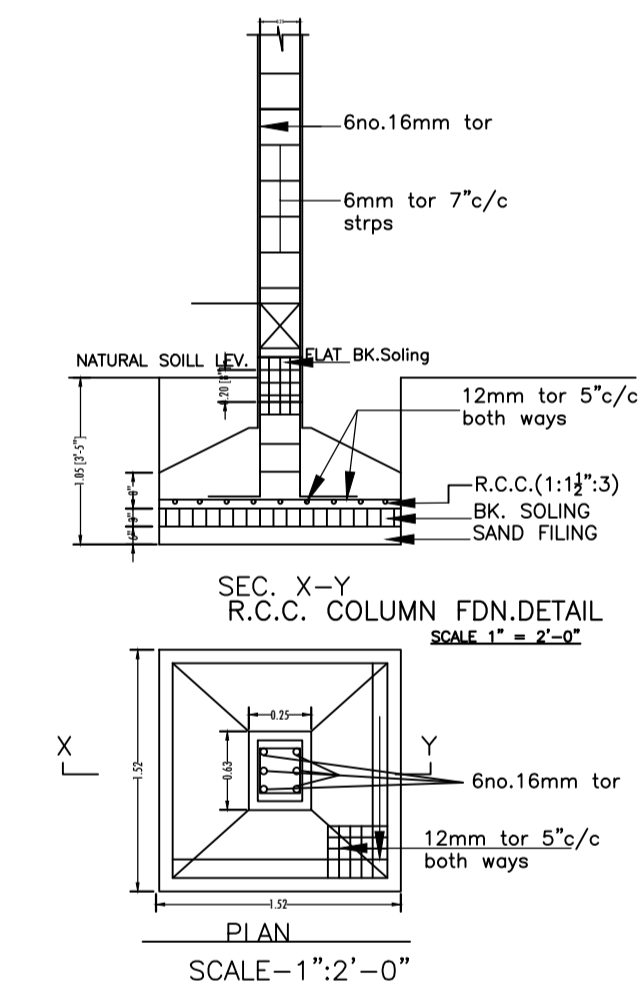

SEC. X-Y R.C.C. COLUMN FDN.DETAIL SCALE 1" = 2'-0"

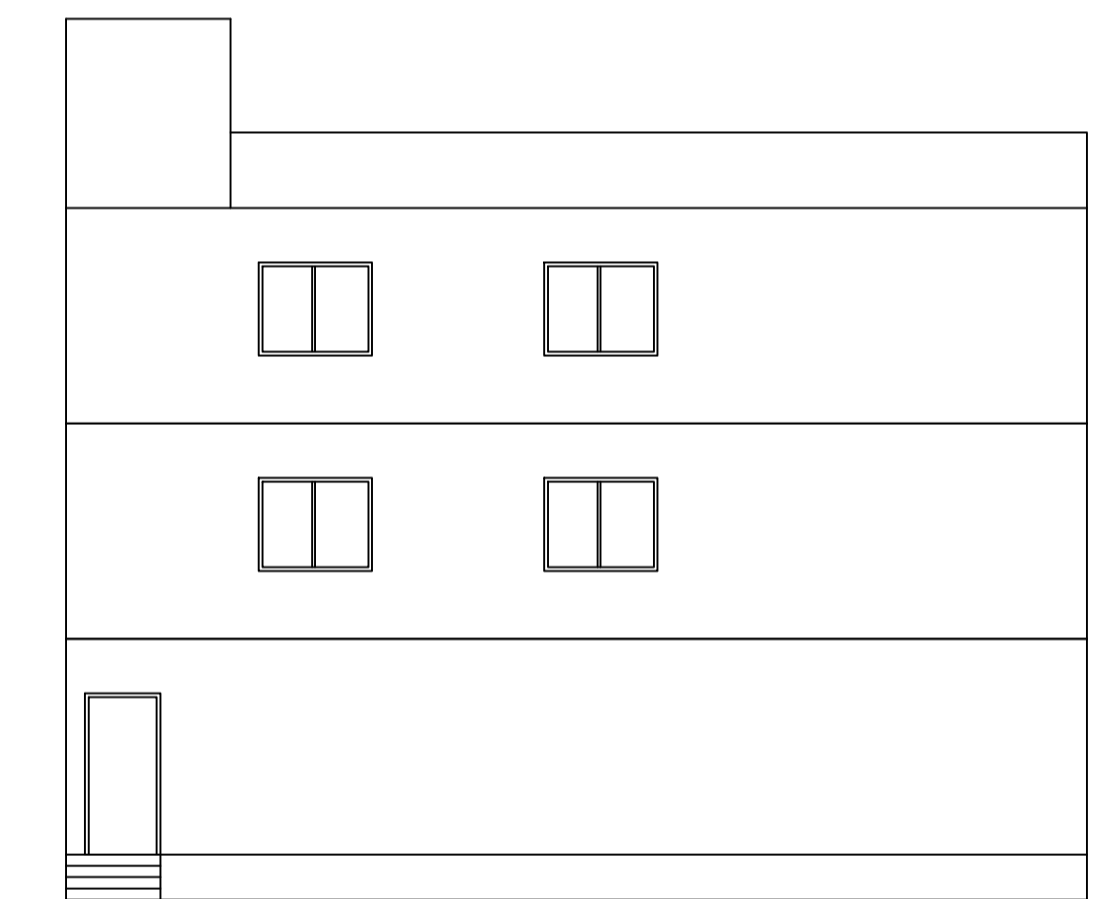

SIDE ELEVATION SCALE :: 1=100

SCHEDULE OF DOOR:

BUILDING NAME	NAME	LENGTH	HEIGHT	NOS
AA (SHAHJADI KHATUN)	D2	0.75	2.10	01
AA (SHAHJADI KHATUN)	D1	0.90	2.10	01
AA (SHAHJADI KHATUN)	D	1.00	2.10	08
AA (SHAHJADI KHATUN)	R/S2	2.00	2.10	01
AA (SHAHJADI KHATUN)	R/S	3.00	2.40	01
AA (SHAHJADI KHATUN)	R/S1	3.00	2.40	02

SCHEDULE OF WINDOW/VENTILATION:

BUILDING NAME	NAME	LENGTH	HEIGHT	NOS
AA (SHAHJADI KHATUN)	V	0.60	0.60	01
AA (SHAHJADI KHATUN)	W1	1.20	1.20	01
AA (SHAHJADI KHATUN)	W	1.50	1.20	10

UnitBUA Table for Building -AA (SHAHJADI KHATUN)

FLOOR	Name	UnitBUA Type	UnitBUA Area	Carpet Area	No. of Rooms	No. of Tenement
GROUND FLOOR PLAN	SHOP	SHOP	39.69	38.75	3	1
FIRST FLOOR PLAN	SPLIT FLAT A	FLAT	110.00	108.45	5	1
SECOND FLOOR PLAN	SPLIT FLAT A	FLAT	0.00	0.00	5	0
Total:	-	-	149.69	147.20	13	2

Building -AA (SHAHJADI KHATUN)

Floor Name	Total Built Up Area (Sq.mt.)	Proposed FAR Area (Sq.mt.)		Total FAR Area (Sq.mt.)	Total Consumed Additional FAR Area (Sq.mt.)	Tnmt (No.)
		Resi.	Commercial			
Ground Floor	70.76	0.00	70.76	70.76	70.76	01
First Floor	70.76	70.76	0.00	70.76	70.76	01
Second Floor	70.76	70.76	0.00	70.76	70.76	00
Terrace Floor	0.00	0.00	0.00	0.00	0.00	00
Total :	212.28	141.52	70.76	212.28	212.28	02
Total Number of Same Buildings	1					
Total :	212.28	141.52	70.76	212.28	212.28	02

LTP NAME AND SIGNATURE	STRUCTURAL ENG'S NAME AND SIGNATURE	BUILDER NAME AND SIGNATURE	DIGITAL SIGNATURE
MD SHOAIB ALAM JNP/ENG/001/2017			

