

SITE PLAN

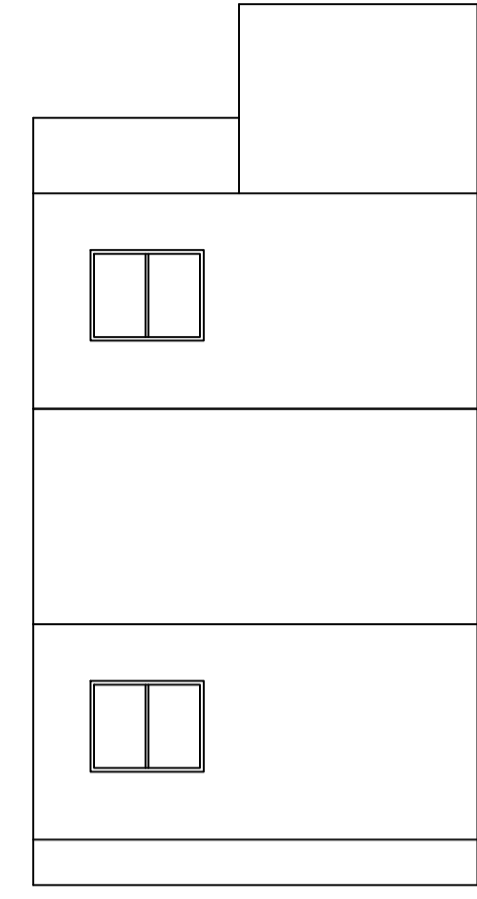
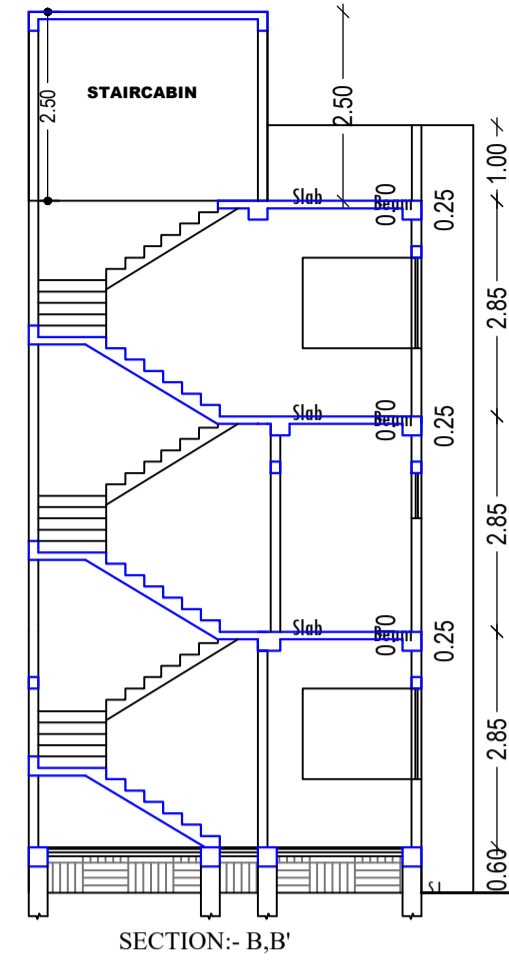
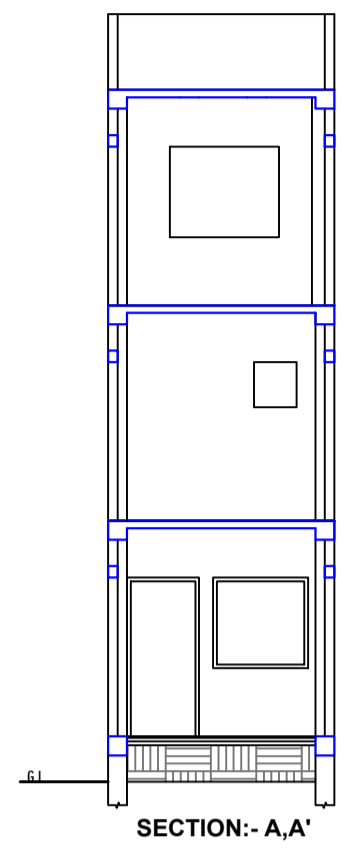

SIDE ELEVATION

FAR & Tenement Details (Table 4-1)

Building	No. of Same Bldg	Total Built Up Area (Sq.mt.)	Proposed FAR Area (Sq.mt.) Resi.	Total FAR Area (Sq.mt.)	Total Consumed Additional FAR Area (Sq.mt.)	Tnmt (No.)
AA (JULEKHA KHATUN)	1	47.61	47.61	47.61	47.61	01
Grand Total :	1	47.61	47.61	47.61	47.61	01

Proposal Basic Information

Proposal File No.	JNP/IBP/0024/W06/2023
Owner Name	JULEKHA KHATUN
Khata No	21/124
Plot No	1301
Village Name	Asana
Use	Residential
SubUse	Bungalow/ Dwelling / Non Apartment

AREA STATEMENT

AREA DETAILS:		SQ. MT.
AREA OF PLOT (Minimum)	(A)	30.91
NET AREA OF PLOT (Gross Plot Area - Deduction from Gross Plot area)	(A-Deductions)	30.91
Deduction for Balance Plot Area (from Gross Plot Area)		
Common Plot		2.26
BALANCE AREA OF PLOT (Net Plot Area - Recreational/Amenity space)	(A-Deductions)	28.65
PLOT AREA FOR COVERAGE (Net Plot Area)	(A-Deductions)	30.91
Plot Area for FAR (Net Plot Area + Road Widening Area)	(A-Deductions)	30.91
COVERAGE CHECK		
Permissible Coverage area (70.00 %)		21.64
Proposed Coverage Area (51.34 %)		15.87
Total Prop. Coverage Area (51.34 %)		15.87
Balance coverage area (18.67 %)		5.77
FAR CHECK		
Perm. FAR Area (2.000)		61.82
Total Perm. FAR area		61.82
Residential FAR		47.60
Proposed FAR Area		47.60
Total Proposed FAR Area		47.60
Consumed FAR (Factor)		1.54
Balance FAR Area		14.22
BUILT UP AREA CHECK		
Total Proposed BuiltUp Area		47.61
ARCHITECT (Regd)	MD SHOAB ALAM	
ENGINEER (Regd)		
SUPERVISOR (Regd)		
OWNER (Regd)	JULEKHA KHATUN	
DEVELOPMENT AUTHORITY		LOCAL BODY

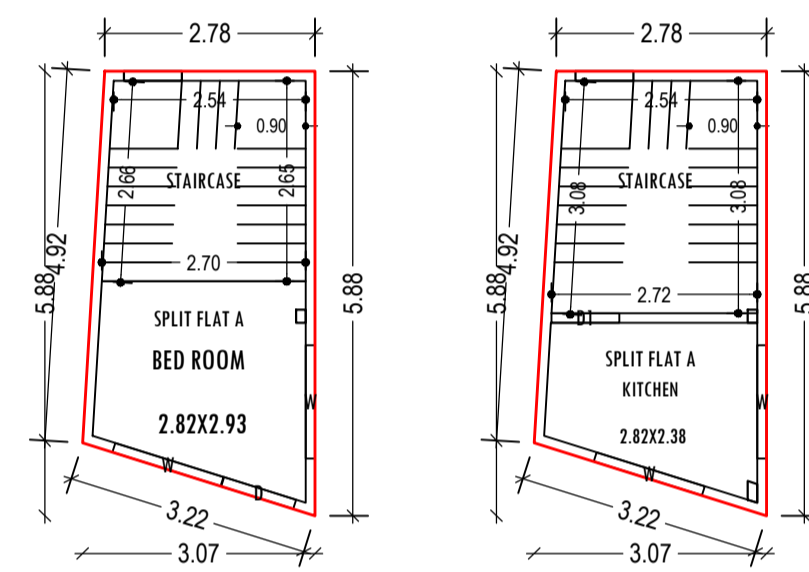

GROUND FLOOR PLAN
(Proposed)
(SCALE 1:100)

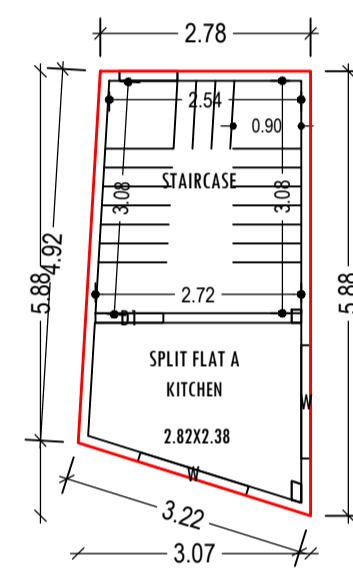

SECOND FLOOR PLAN
(Proposed)
(SCALE 1:100)

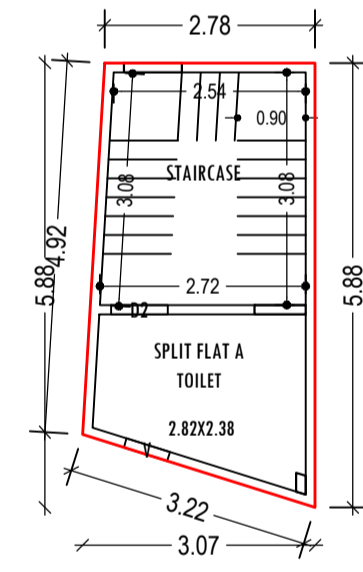

FIRST FLOOR PLAN
(Proposed)
(SCALE 1:100)

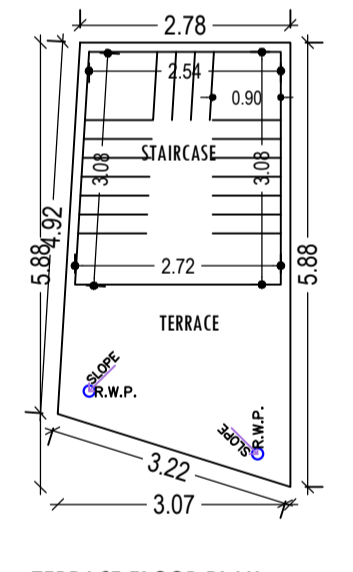

TERRACE FLOOR PLAN
(SCALE 1:100)

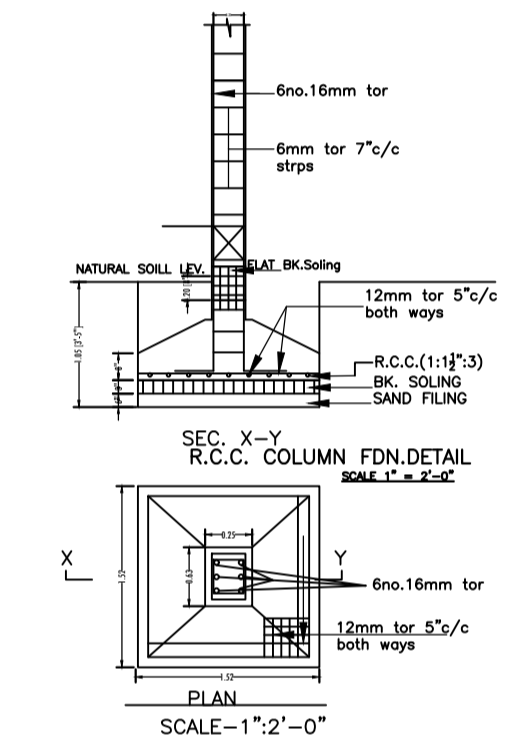
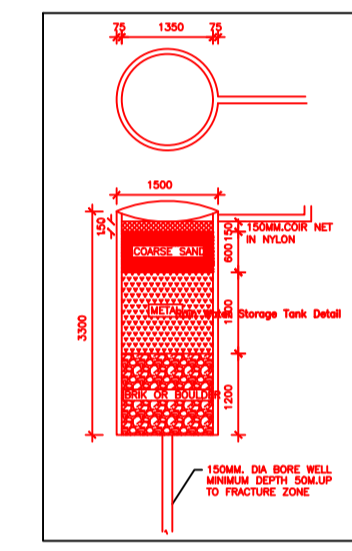

COLOR INDEX

PLOT BOUNDARY	Black
ABUTTING ROAD	Red
PROPOSED CONSTRUCTION	Green
COMMON PLOT	Yellow
ROAD WIDENING AREA	Blue
EXISTING (To be retained)	Light Blue
EXISTING (To be demolished)	White

SCHEDULE OF DOOR:

BUILDING NAME	NAME	LENGTH	HEIGHT	NOS
AA (JULEKHA KHATUN)	D2	0.75	2.10	01
AA (JULEKHA KHATUN)	D1	0.90	2.10	01
AA (JULEKHA KHATUN)	D	1.00	2.10	01

SCHEDULE OF WINDOW/VENTILATION:

BUILDING NAME	NAME	LENGTH	HEIGHT	NOS
AA (JULEKHA KHATUN)	V	0.60	0.60	01
AA (JULEKHA KHATUN)	W	1.50	1.20	04

UnitBUA Table for Building -AA (JULEKHA KHATUN)

FLOOR	Name	UnitBUA Type	UnitBUA Area	Carpet Area	No. of Rooms	No. of Tenement
GROUND FLOOR PLAN	SPLIT FLAT A	FLAT	17.69	17.60	1	1
FIRST FLOOR PLAN	SPLIT FLAT A	FLAT	0.00	0.00	1	0
SECOND FLOOR PLAN	SPLIT FLAT A	FLAT	0.00	0.00	1	0
Total:	-	-	17.69	17.60	3	1

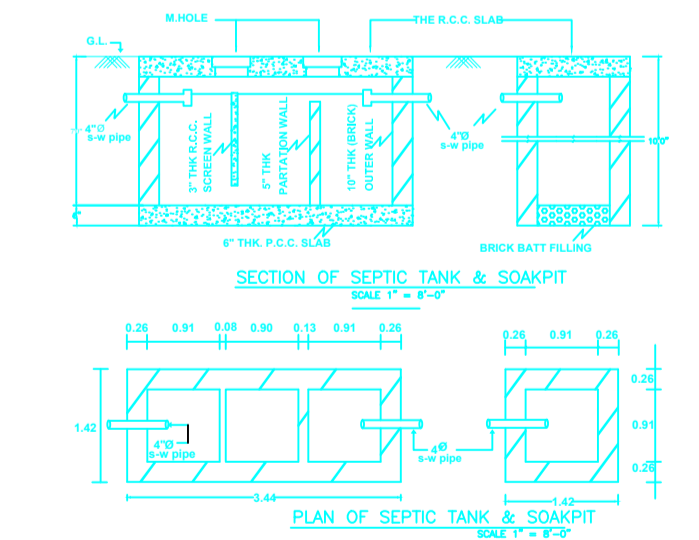
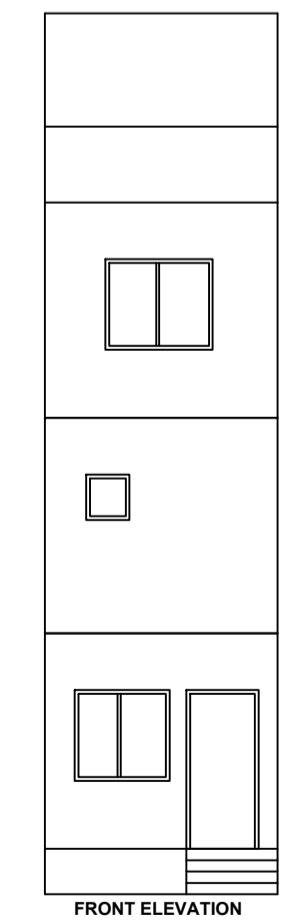

PLAN OF SEPTIC TANK & SOAKPIT

Buildingwise Floor FAR Details

Floor Name	Building Name AA (JULEKHA KHATUN)		Total	
	Proposed Built Up Area (Sq.mt.)	Proposed FAR Area (Sq.mt.)	Total Proposed Built Up Area (Sq.mt.)	Total FAR Area (Sq.mt.)
Ground Floor	15.87	15.87	15.87	15.87
First Floor	15.87	15.87	15.87	15.87
Second Floor	15.87	15.87	15.87	15.87
Terrace Floor	0.00	0.00	0.00	0.00
Total :	47.61	47.61	47.61	47.61

Building USE/SUBUSE Details

Building Name	Building Use	Building SubUse	Building Structure
AA (JULEKHA KHATUN)	Residential	Bungalow/ Dwelling / Non Apartment	Non-Highrise

Building -AA (JULEKHA KHATUN)

Floor Name	Total Built Up Area (Sq.mt.)	Proposed FAR Area (Sq.mt.) Resi.	Total FAR Area (Sq.mt.)	Total Consumed Additional FAR Area (Sq.mt.)	Tnmt (No.)
Ground Floor	15.87	15.87	15.87	15.87	01
First Floor	15.87	15.87	15.87	15.87	00
Second Floor	15.87	15.87	15.87	15.87	00
Terrace Floor	0.00	0.00	0.00	0.00	00
Total :	47.61	47.61	47.61	47.61	01
Total Number of Same Buildings	1				
Total :	47.61	47.61	47.61	47.61	01

LTP NAME AND SIGNATURE	STRUCTURAL ENG'S NAME AND SIGNATURE	BUILDER NAME AND SIGNATURE	DIGITAL SIGNATURE
MD SHOAB ALAM JNP/ENG/001/2017			