

GROUND FLOOR PLAN (Proposed) (SCALE 1:100)

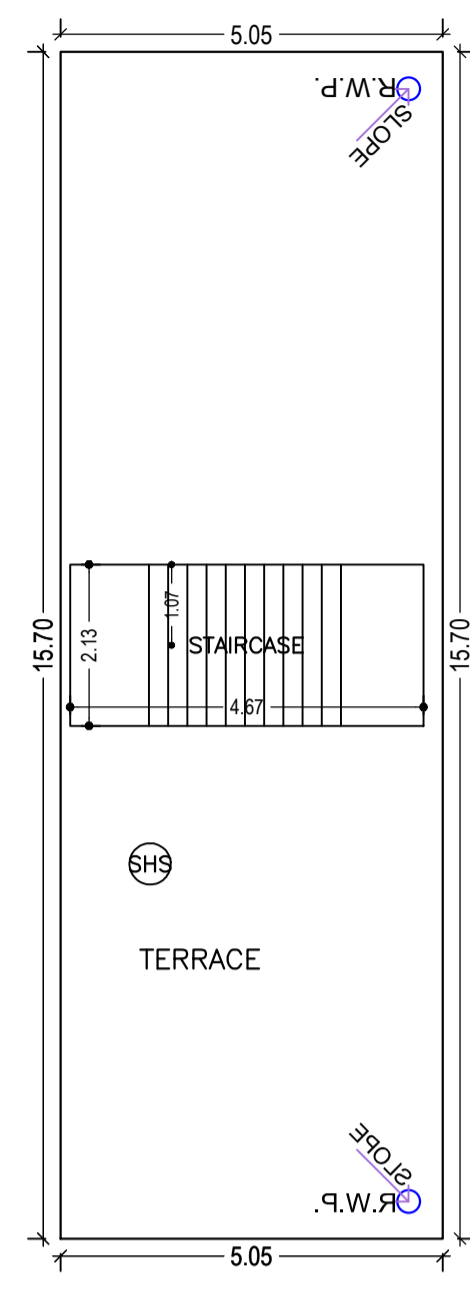

TERRACE FLOOR PLAN (SCALE 1:100)

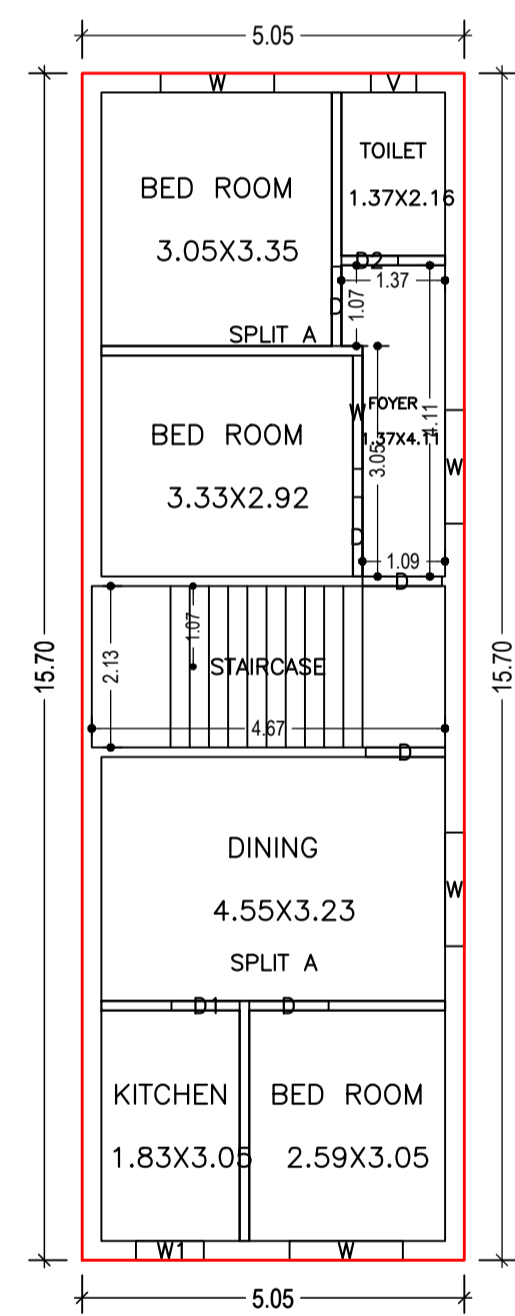

FIRST FLOOR PLAN (Proposed) (SCALE 1:100)

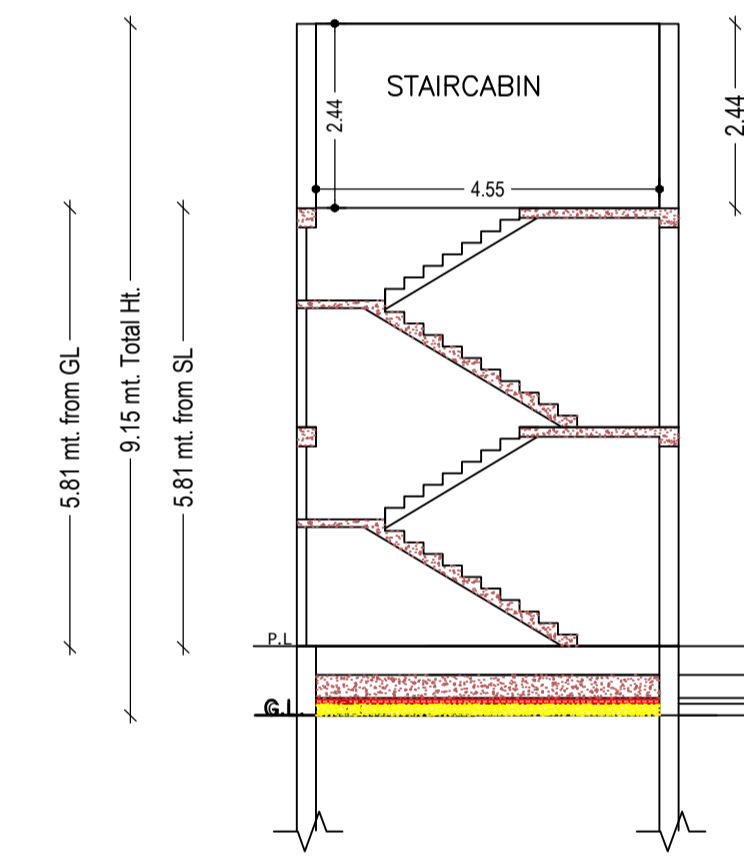

CROSS SECTION (A)

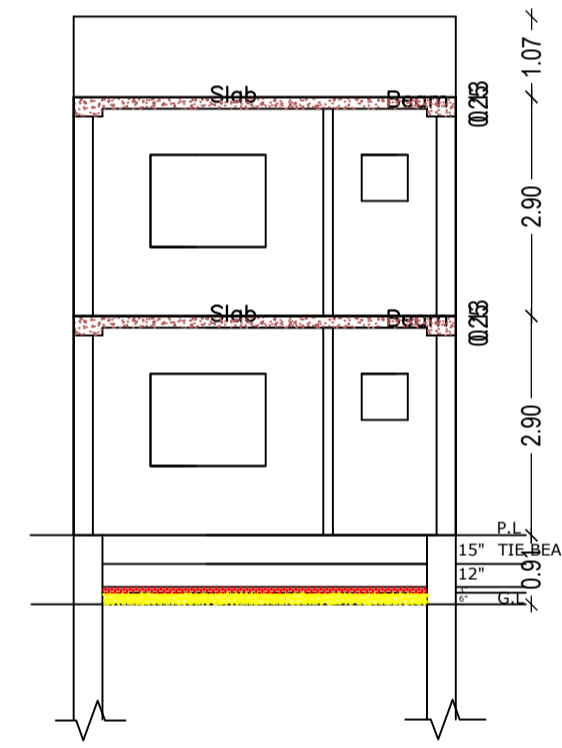

CROSS SECTION (B)

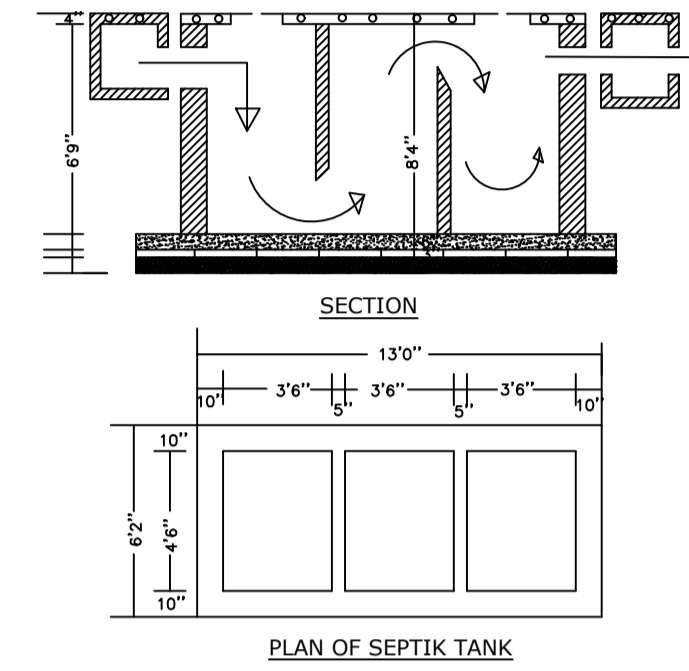

PLAN OF SEPTIK TANK

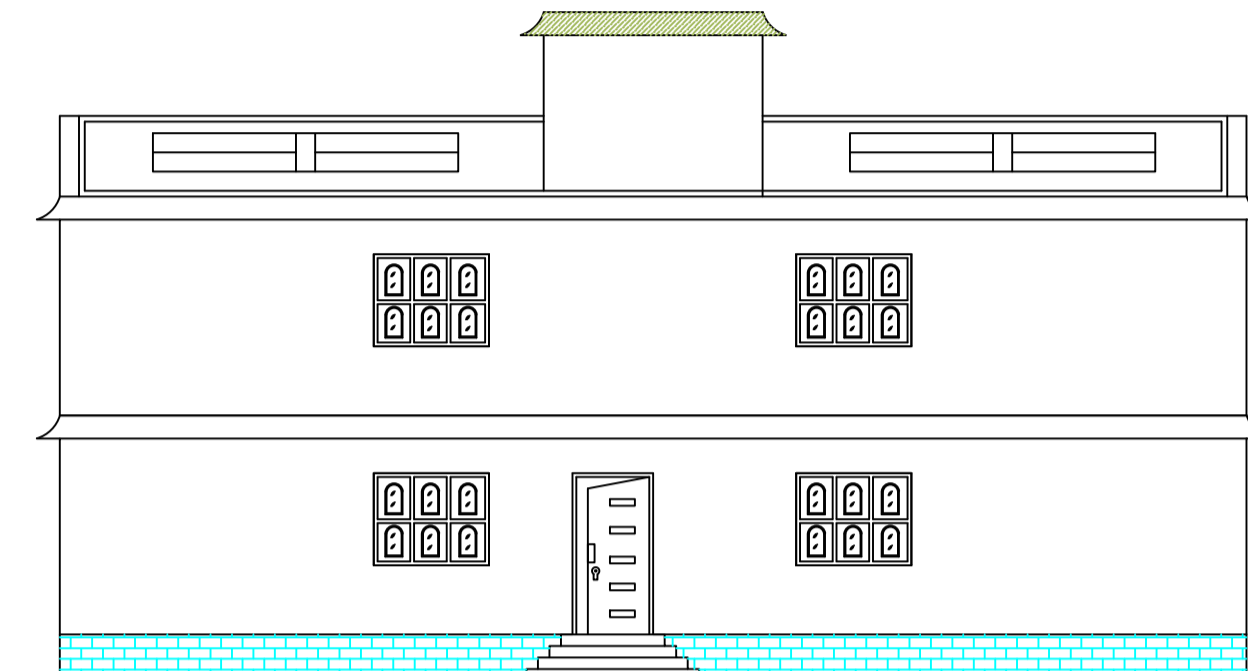

CROSS ELEVATION

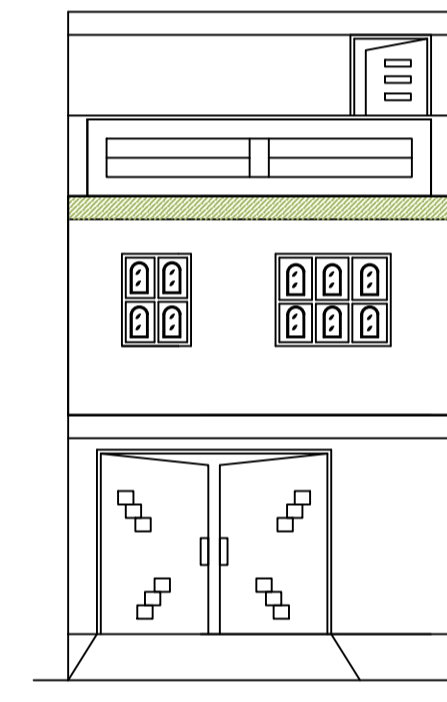

FRONT ELEVATION

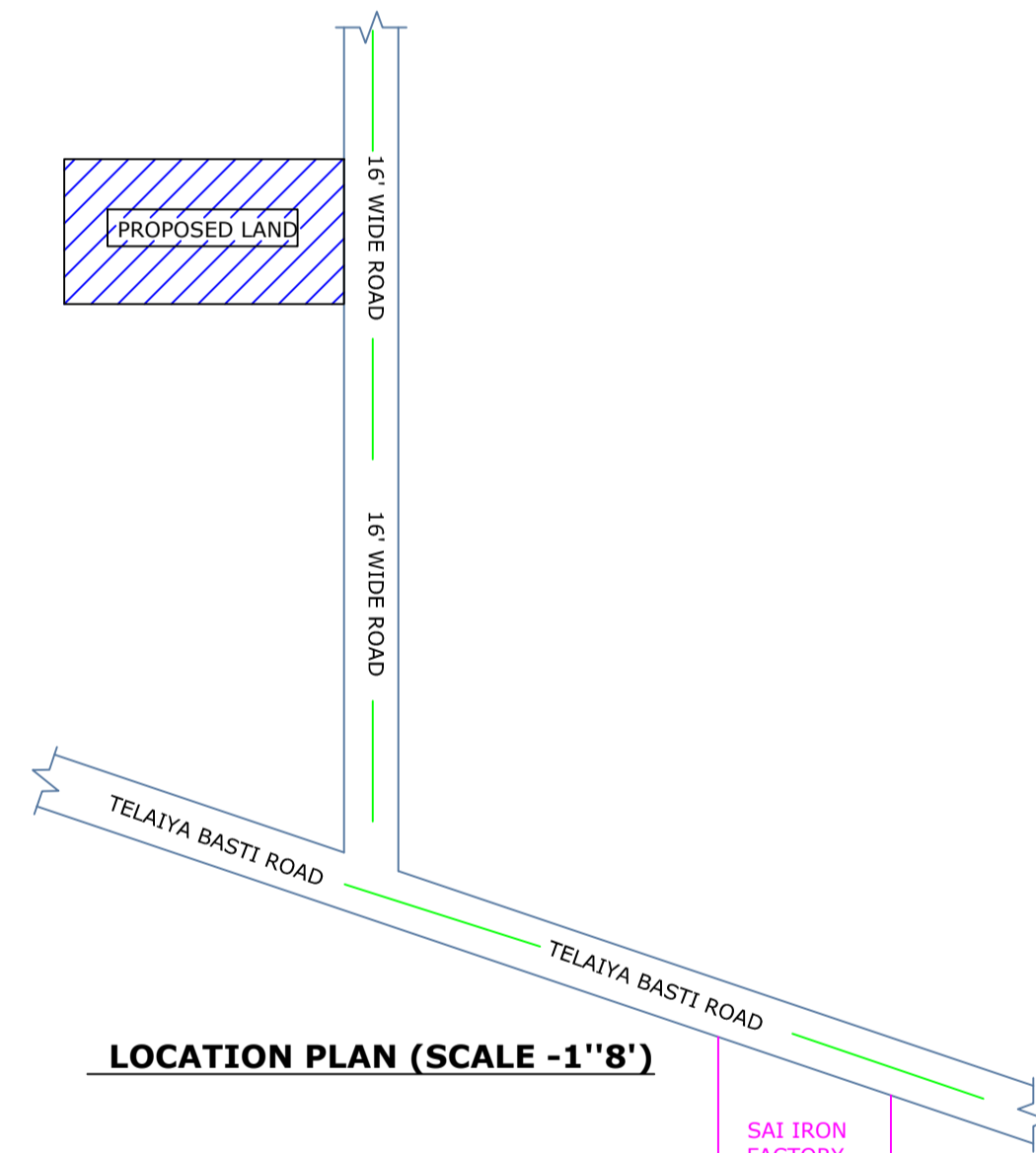

LOCATION PLAN (SCALE -1'8'')

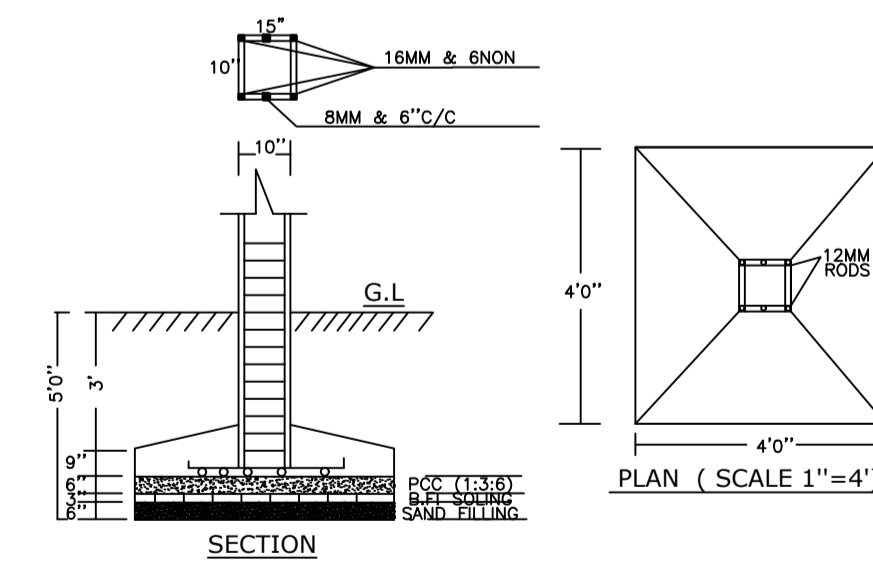

SECTION

PLAN (SCALE 1'11'')

FAR & Tenement Details (Table 4c-1)

Building	No. of Same Bldg	Total Built Up Area (Sq.mt.)	Deductions (Area in Sq.mt.)	Proposed FAR Area (Sq.mt.)	Total FAR Area (Sq.mt.)	Total Consumed Additional FAR Area (Sq.mt.)	Tnmt (No.)
A (RESIDENTIAL)	1	158.69	33.64	125.05	125.05	125.05	01
Grand Total :	1	158.69	33.64	125.05	125.05	125.05	01

Proposal Basic Information

Proposal File No.	JNP/IBP/0004/W02/2023
Owner Name	SMT NANDITA KUMARI
Khata No	123, 912
Plot No	3221, 3222
Village Name	Tilaiya
Use	Residential
SubUse	Bungalow/ Dwelling / Non Apartment

AREA STATEMENT	VERSION NO. : 1.0.65	SQ.MT.
JHUMRITILAIYA NAGAR PARISHAD	VERSION DATE: 16/10/2020	
PROJECT DETAIL:		
Region: JHARKHAND URBAN LOCAL BODIES	Plot Use: Residential	
District: KODERMA	Plot SubUse: Bungalow/ Dwelling / Non Apartment	
Authority: JHUMRITILAIYA NAGAR PARISHAD	PlotNearbyReligiousStructure: NA	
Inward No: JNP/IBP/0004/W02/2023	Plot/SubPlot No: 3221, 3222	
Application Type: General Proposal	North: Plot No. - LAND OF SMT SANJAY RAY	
Project Type: Building Permission	South: Plot No. - LAND OF VENDOR	
Nature of Development: New	East: Road Width - 5.25	
Location of Development Area: Old Area	West: Plot No. - LAND OF MADHUSUDHAN DARUKA	
AREA DETAILS:		
AREA OF PLOT (Minimum)	(A)	121.28
NET AREA OF PLOT(Gross Plot Area - Deduction from Gross Plot area)	(A-Deductions)	121.28
Deduction for Balance Plot Area(from Gross Plot Area)		
Common Plot		9.33
Total		9.33
BALANCE AREA OF PLOT(Net Plot Area - Recreational/Amenity space)	(A-Deductions)	111.95
PLOT AREA FOR COVERAGE(Net Plot Area)	(A-Deductions)	121.28
Plot Area for FAR (Net Plot Area + Road Widening Area)	(A-Deductions)	121.28
COVERAGE CHECK		
Permissible Coverage area (70.00 %)		84.90
Proposed Coverage Area (65.42 %)		79.34
Total Prop. Coverage Area (65.42 %)		79.34
Balance coverage area (4.58 %)		5.56
FAR CHECK		
Perm. FAR Area (1.800)		218.30
Total Perm. FAR area		218.30
Residential FAR		125.05
Proposed FAR Area		125.05
Total Proposed FAR Area		125.05
Consumed FAR (Factor)		1.03
Balance FAR Area		93.25
BUILT UP AREA CHECK		
Total Proposed BuiltUp Area		158.69
ARCHITECT (Regd)	KIRAN KUMARI	
ENGINEER (Regd)		
SUPERVISOR (Regd)		
OWNER (Regd)	SMT NANDITA KUMARI	
DEVELOPMENT AUTHORITY LOCAL BODY		

COLOR INDEX	
PLOT BOUNDARY	Black
ABUTTING ROAD	Green
PROPOSED CONSTRUCTION	Red
COMMON PLOT	Yellow
ROAD WIDENING AREA	Blue
EXISTING (To be retained)	Light Blue
EXISTING (To be demolished)	Dark Blue

Buildingwise Floor FAR Details

Floor Name	Building Name A (RESIDENTIAL)		Total	
	Proposed Built Up Area (Sq.mt.)	Proposed FAR Area (Sq.mt.)	Total Proposed Built Up Area (Sq.mt.)	Total FAR Area (Sq.mt.)
Ground Floor	79.35	45.71	79.35	45.71
First Floor	79.34	79.34	79.34	79.34
Terrace Floor	0.00	0.00	0.00	0.00
Total :	158.69	125.05	158.69	125.05

Building USE/SUBUSE Details

Building Name	Building Use	Building SubUse	Building Structure
A (RESIDENTIAL)	Residential	Bungalow/ Dwelling / Non Apartment	Non-Highrise

Building :A (RESIDENTIAL)

Floor Name	Total Built Up Area (Sq.mt.)	Deductions (Area in Sq.mt.)	Proposed FAR Area (Sq.mt.)	Total FAR Area (Sq.mt.)	Total Consumed Additional FAR Area (Sq.mt.)	Tnmt (No.)
Ground Floor	79.35	33.64	45.71	45.71	45.71	01
First Floor	79.34	0.00	79.34	79.34	79.34	00
Terrace Floor	0.00	0.00	0.00	0.00	0.00	00
Total :	158.69	33.64	125.05	125.05	125.05	01
Total Number of Same Buildings	1					
Total :	158.69	33.64	125.05	125.05	125.05	01

SCHEDULE OF DOOR:

BUILDING NAME	NAME	LENGTH	HEIGHT	NOS
A (RESIDENTIAL)	D2	0.75	2.10	02
A (RESIDENTIAL)	D1	0.90	2.10	02
A (RESIDENTIAL)	D	1.05	2.10	07

SCHEDULE OF WINDOW/VENTILATION:

BUILDING NAME	NAME	LENGTH	HEIGHT	NOS
A (RESIDENTIAL)	V	0.60	0.90	02
A (RESIDENTIAL)	W1	0.90	1.20	02
A (RESIDENTIAL)	W	1.50	1.20	07

UnitBUA Table for Building :A (RESIDENTIAL)

FLOOR	Name	UnitBUA Type	UnitBUA Area	Carpet Area	No. of Rooms	No. of Tenement
GROUND FLOOR PLAN	SPLIT A	FLAT	87.31	83.56	4	1
FIRST FLOOR PLAN	SPLIT A	FLAT	0.00	0.00	4	0
PLAN	SPLIT A	FLAT	0.00	0.00	3	0
Total:	-	-	87.31	83.56	11	1

LTP NAME AND SIGNATURE	STRUCTURAL ENG'S NAME AND SIGNATURE	BUILDER NAME AND SIGNATURE	DIGITAL SIGNATURE
KIRAN KUMARI JNP/ENG/0001/2019			